



ADOPTED  
Planning Commission [date]

# BROADWAY

STREETSCAPE MASTER PLAN

FEBRUARY 2013 DRAFT

THIS PAGE LEFT INTENTIONALLY BLANK

# ACKNOWLEDGEMENTS

## PROJECT TEAM

### CRA/LA

Lillian Burkenheim

Curt Gibbs

Ed Huang

### Bringing Back Broadway

Councilmember José Huizar

Jessica Wethington McLean

### The City of Los Angeles

Bureau of Engineering

Bureau of Street Lighting

Bureau of Street Services

Los Angeles Department of Transportation (LADOT)

Department of City Planning

Urban Design Studio

Department of Cultural Affairs

Community Development Department

### Metro

## COMMUNITY STAKEHOLDERS

Central City Association

Downtown Center BID

Historic Downtown Business Improvement District

Fashion District BID

Downtown Los Angeles Neighborhood Council

Los Angeles Streetcar, Inc.

Los Angeles Conservancy

Los Angeles Historic Theatre Foundation

Los Angeles Area Chamber of Commerce

## DESIGN TEAM

### Meléndrez

Melani Smith

Scott Baker

Darren Shirai

Valerie Watson

Tony Lopez

### IBI Group

Steve Schibuola

Gary Hartnett

David Aulwes

Guy De Lijster

Jeesong Chung

Bill Delo

Lydia LaPoint

### Selbert Perkins Design

Robin Perkins

Andrew Davey

Paul Nagakura

### Cumming

Philip Mathur

Trevor Shulters

THIS PAGE LEFT INTENTIONALLY BLANK

# GUIDE TO THIS DOCUMENT

The Streetscape Master Plan is organized into the following chapters:

## 1 • Introduction

Describes the history of the Broadway Streetscape, a summary of the efforts of Bringing Back Broadway, the purpose of this Streetscape Master Plan, the Plan's scope of work and project process, and its policy context.

## 2 • Existing Conditions

Describes and documents the existing conditions of the public realm of Broadway, including various elements of the streetscape, historic fabric, open space and other opportunity areas, utilities, and signage.

## 3 • Vision

Describes the community's preferred future for the street and lays a foundation for the design of this Streetscape Master Plan and its future implementation.

## 4 • Streetscape Plan

Presents the stakeholder Preferred Design and identifies the fundamental building blocks of the streetscape improvements: street configuration; transit stops; curb extensions; midblock crossings; driveways; and street lighting.

## 5 • Materials Palette & Location Criteria

Outlines the catalog of materials, or "kit of parts" of streetscape elements and improvements, that will be applied to Broadway as this Master Plan is implemented.

## 6 • Implementation and Phasing

Identifies a series of steps in which the Master Plan could be implemented, including pilot projects and those immediately implementable upon acquisition of funding.

*On CD in back cover:*

## AP • Appendices

Offers content, materials, studies, design alternatives, and other items supplementary to the Master Plan.

## References

Documents relevant to the Master Plan, with locations or links, if available, to PDF versions of each.

## Project Area

Broadway – 2nd to Olympic

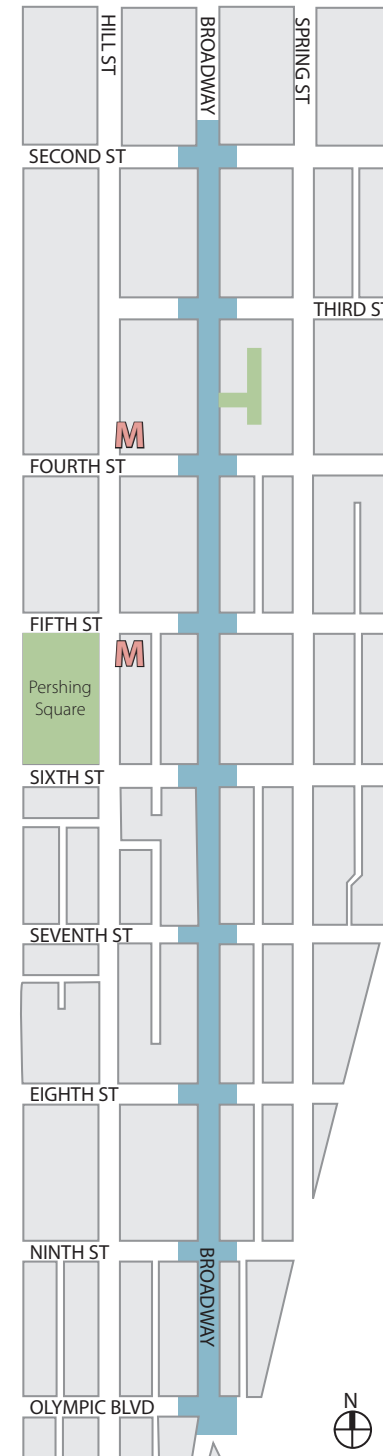

## Project Vicinity

Downtown Los Angeles



THIS PAGE LEFT INTENTIONALLY BLANK

# 1.0 INTRODUCTION

## HISTORY OF THE BROADWAY STREETScape

### Architecture and Commercial Uses

In the first half of the 20th century, Broadway enjoyed success as a business and retail destination and was considered the commercial capital of the nation. Broadway's elegant buildings boast an urban character that compares to famously vibrant cities like New York. The Historic Broadway Theatre District is designated on the National Register of Historic Places. The Broadway District boasts block after block of stunning Beaux Arts, Art Deco, and revival-style buildings which bestow the district with an historic integrity uncommon in major metropolitan downtowns.

### Theatres

The Historic Broadway Theatre District features the largest concentration of historic theatres and movie palaces on one street in the nation, most of which date back to the 1910s, 1920s and 1930s. The twelve remaining theatres are concentrated along six blocks of Broadway, from 3rd to 9th Streets.

### The Streetcar

An extensive streetcar network once ran throughout Downtown Los Angeles and the region as a whole. Composed of the Red Car Line and the Yellow Car Line, the Los Angeles streetcar system for much of its tenure was one of the best in the world, before its demise in the 1950s as bus service was introduced as the way of the future. Several Yellow Car lines once ran down Broadway, bringing multitudes of shoppers, workers and theatregoers to the busy corridor. Red Car lines ran on nearby Hill and Main streets, offering north-south connections to the region. In addition to Broadway, Yellow Cars ran north-south on Hill, Spring, and Main Streets.

Broadway has always been a multi-modal street. From horse and carriage, bicycles, pedestrians, and streetcars, to the automobile and bus, this street has always been well served by transportation choices. With the proposed restoration of downtown streetcar service along Broadway, together with Metro bus services and nearby access to Metro Rail, and the future Regional Connector, the corridor will benefit from even broader multi-modal transportation services in the future.

## BROADWAY TODAY

Today, the Historic Broadway Theatre District is a vibrant daytime pedestrian shopping corridor that shutters at night with roll down metal doors. Some of the historic theatres are in use, as entertainment venues for movies and music, including the the Orpheum Theatre, Million Dollar Theatre, and the Los Angeles Theatre. Other theatres hold performances

and events on occasion, while some have been converted to non-entertainment uses such as churches and flea markets. Through the efforts of Bringing Back Broadway, the Los Angeles Conservancy, and the Los Angeles Historic Theatre Foundation, many theatre owners have pledged to restore their theatres for entertainment use, preserving the historic integrity of the lavish interiors.

Because Broadway is designated as a National Register Historic District, aspects of the street that are deemed as "contributing elements of the historic fabric" are protected and must be preserved. An Historic Architectural Survey was completed in 1998 that lists and describes elements of the streetscape designated as historic, as well as contributing buildings designated as historic. Please refer to the Existing Conditions Chapter as well as the appendix to this document for more information.

## BRINGING BACK BROADWAY

The Broadway Streetscape Master Plan is one component of a larger effort to revitalize the Historic Broadway Theatre District. Bringing Back Broadway is a public-private partnership initiative focused on an ambitious ten-year plan to:

- revitalize the historic Broadway district between 2nd Street and Olympic Boulevard;
- activate inactive theatres;
- re-activate more than a million square feet of vacant commercial space on the upper floors of existing buildings on Broadway;
- assist retailers and prevent further retail vacancies;
- increase parking and transit options to serve Broadway;
- encourage cultural, entertainment and retail uses on Broadway that will sustain generations;
- create a sense of place and history through urban planning, design and lighting guidelines and streetscape improvements;
- and make the dream of the restoration of historic streetcar service downtown a reality.

This Streetscape Master Plan's focus is – in keeping with the breadth of the Bringing Back Broadway Initiative – to create a multi-modal, pedestrian-focused street that will support a thriving, revitalized historic theatre district. This Plan was developed with the proposed operation of restored historic streetcar service on Broadway and throughout Downtown Los Angeles in mind, but is not dependent upon streetcar service.

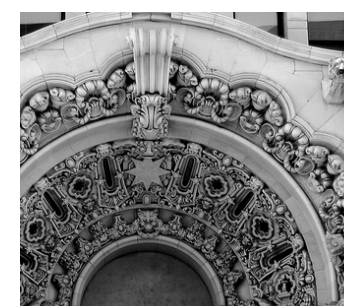
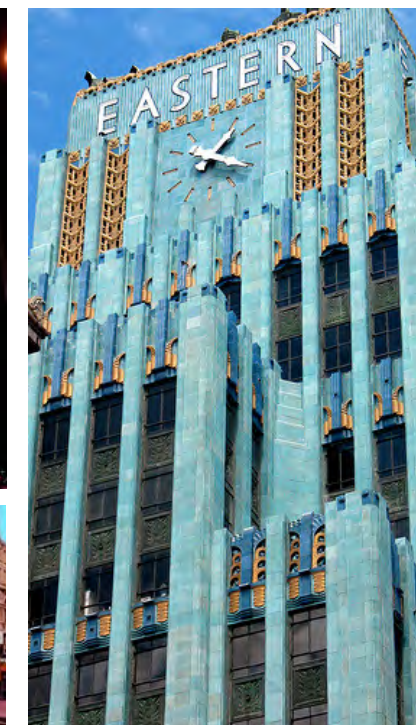

## THE BROADWAY STREETScape MASTER PLAN

### Overview

The Broadway Streetscape reflects the dedicated participation and input of City of Los Angeles department representatives, Broadway stakeholders, and the community at large.

The Streetscape Master Plan will work in concert with other Bringing Back Broadway initiatives, each with a specific focus. The **Broadway Entertainment Community Design Overlay Zone and Design Guide (Broadway CDO)** provides design, signage, and historic lighting guidelines to support entertainment and cultural uses on Broadway.

**Los Angeles Streetcar, Inc.** is a public/private non-profit partnership, working closely with Bringing Back Broadway, that is focused on restoring the historic streetcar service in Downtown Los Angeles. A restored streetcar line is intended to traverse the Historic Broadway Theatre District.

Bringing Back Broadway is also leading efforts to develop **Historic Commercial Reuse Guidelines** that will provide guidance on utilizing the California Historical Building Code to create incentives to encourage the reuse and reactivation of vacant upper floor commercial space and assist with the filling of ground floor vacancies of buildings along Broadway. In addition, Bringing Back Broadway is working to revitalize the **historic theatres** themselves that line the corridor, working with theatre owners to restore the theatres for the entertainment uses they once housed.

### Purpose of the Document

The master plan for the design of the Broadway Streetscape included in this document contains a vision for the improvements to the corridor's public realm. It offers an array of design tools and streetscape elements, a kit-of-parts, as well as criteria with which to apply these to the individual blocks that make up the corridor.

The project area under the purview of this Streetscape Master Plan is the eight blocks on Broadway from 2nd Street to Olympic Boulevard in Downtown Los Angeles, as shown in Figure 1-1. Major destinations and features located near the project area include Pershing Square, the future Spring Street Park on Spring between 4th and 5th Streets, City Hall and the Downtown Civic Center, Metro Red Line Pershing Square Station, and a proposed station location for the future Regional Connector (Broadway and 2nd Street).

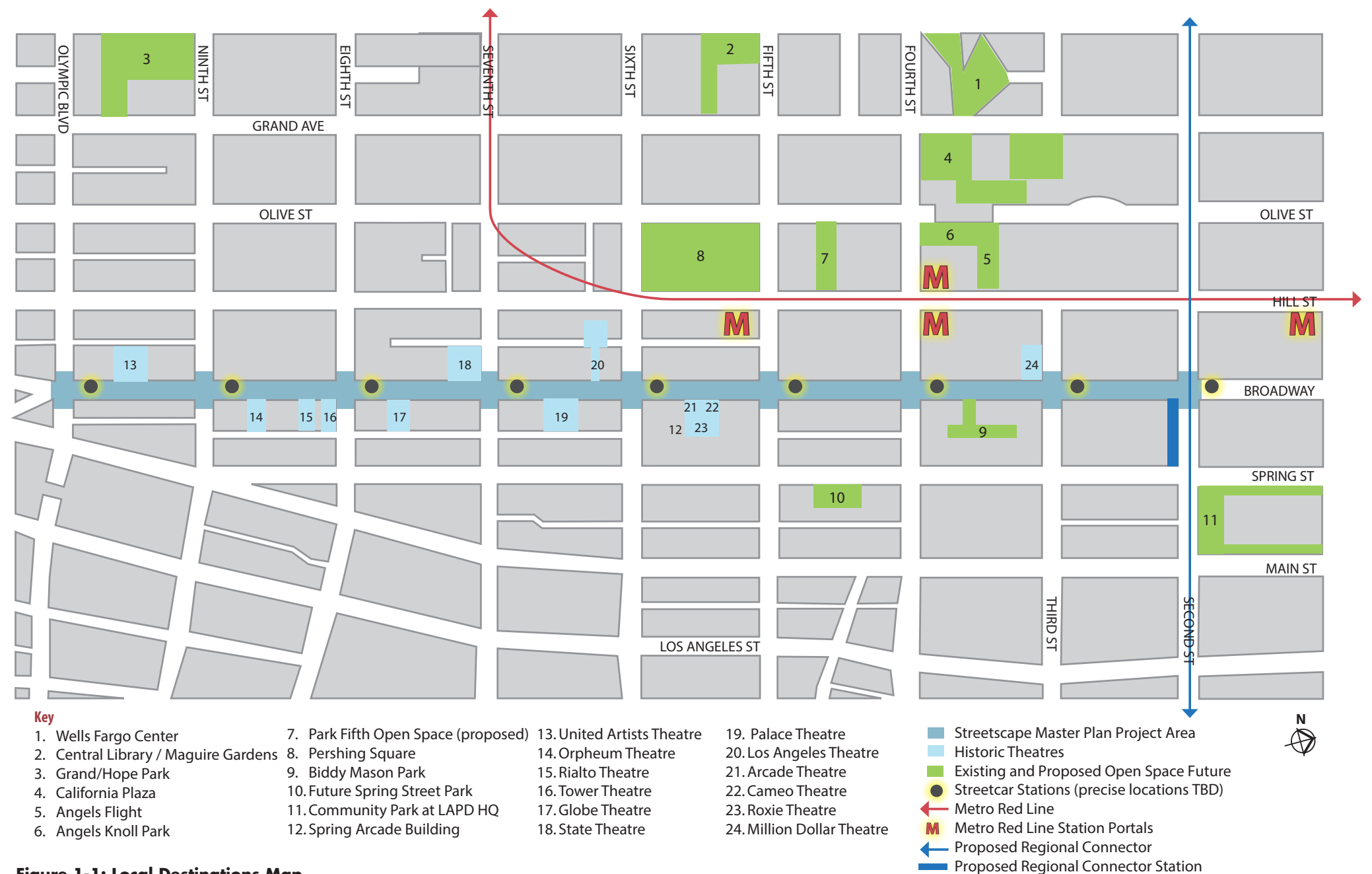

**Figure 1-1: Local Destinations Map**

---

## RELEVANT PLANS AND PROGRAMS

Several key plans and programs relevant to Downtown Los Angeles and Broadway were reviewed as part of understanding the regulatory context for this project.

### Central City Community Plan

The General Plan for land use in the City of Los Angeles is composed of thirty-five community plans which guide physical growth and development in the City's neighborhoods and encourage sustainable growth patterns while balancing the unique character of individual communities.

The Central City Community Plan covers the Downtown area, including the project area for the Broadway Streetscape Master Plan. Under the community plan, Broadway from 2nd Street to Olympic Boulevard is designated as Regional Commercial (except for a parcel at the southwest corner of Broadway and 4th, which is a government building and designated as Public Facility), with an FAR of 6:1. Broadway, like a majority of Downtown streets, is classified as a modified Secondary Highway.

### Downtown Design Guide

The Downtown Design Guide, adopted in April 2009, establishes development design standards and guidelines for private development in Downtown Los Angeles. The focus of the Design Guide is on the relationship of the buildings to the street, including sidewalk treatment, the character of the building as it adjoins the sidewalk and connections to transit, forming the basis for providing high quality development at a human scale. As it relates to Broadway, the Downtown Design Guide sets forth standards for the width of sidewalks, street trees, tree wells, planted parkways, storm water management, and other aspects of street design.

### Downtown Street Standards

As new development and adaptive reuse of historic buildings in Downtown Los Angeles occurs, the application of the City-wide standards for street design called forth by the Central City Community Plan, part of the overall General Plan for the City, have revealed issues with building setbacks and sidewalk widths in this highly dense, urban part of Los Angeles. To address the specific context of the historic core of our City, and the specific needs of each individual street, the Downtown Street Standards have been created to update the Central City Community Plan street designations based on a comprehensive street hierarchy that balances traffic flow with other equally important functions of the street, including: pedestrian needs, public transit routes and stops, bicycle routes, historic districts with fixed building street walls, the public face and transitional "front yard" of businesses, pedestrian environments and linear open space considerations.

The Downtown Street Standards, adopted in April 2009, address Broadway and call for four 10' travel lanes, two 8' parking lanes, and a total minimum sidewalk width of 17', consisting of a minimum dedicated sidewalk width of 12' and a required 5' sidewalk easement. However, in multiple meetings, and with review of the traffic analysis described above, the Street Standards Committee, an interdepartmental group with representatives from City Planning, Urban Design Studio, LADOT, Bureau of Engineering, and others, agreed that the three travel lane solution proposed in this Plan is appropriate for Broadway.

### Broadway Community Design Overlay

The Broadway Community Design Overlay (CDO) provides guidelines and standards for development projects along Broadway between 2nd Street and Olympic Boulevard in Downtown Los Angeles. The intent of the Broadway CDO is to provide guidance and direction in the rehabilitation of existing structures and the design of new buildings to improve the appearance, enhance the identity and promote the pedestrian environment of the Broadway corridor and to encourage the development of a regional entertainment district centered around its twelve historic theatres. The Broadway CDO has been developed to create a recognizable and attractive entertainment district on Broadway that encourages the preservation and reuse of all historic buildings as well as development patterns that provide a mix of entertainment-related, pedestrian and visitor-serving uses that contribute to an expanded activity center within Downtown and create better, safer linkages among Downtown districts. Together with this Streetscape Master Plan, which covers design standards for the public realm, or streetscape, of Broadway, a comprehensive set of guidelines and standards has been established to promote the revitalization of the District.

### Broadway Sign District

A Supplemental Use District for signage is currently under development for Broadway as a way to acknowledge and promote the continuing contribution of signage to the distinctive aesthetic of the district. The new signage ordinance is also intended to provide incentives for the rehabilitation and reactivation of buildings, while complementing and protecting the character-defining feature of the historic buildings, supporting and encouraging pedestrian activity, and limiting visual clutter along the street.

---

## ADMINISTRATION

The standards established by the Broadway Streetscape Master Plan apply to all projects and improvements, public and private, within the public right-of-way, as shown in Figure 1-1. The public right-of-way is that area between property lines on each side of the street within the Plan area (Broadway from 2nd to Olympic).

Within these Design Guidelines and Standards, the strongest level of design intent is specified by the use of terms such as “must” and “shall.” Preferred design elements are designated as a condition which is “encouraged”, “preferred,” “recommended,” “appropriate,” or as one that “should,” or “may” be included. Streetscape design elements that include one or more criteria or elements that are qualified as “discouraged”, “inappropriate”, or “should not” be included, or elements that do not include one or more criteria or elements that “must” or “shall” be included, are nonetheless acceptable if as part of the project review the totality of the proposed design is found to be consistent with the overall design, intent, and goals of these Design Guidelines and Standards. Elements not found within this plan are therefore not precluded from future implementation as long as they are in keeping with the overall design intent expressed in this plan.

### Project Definition

Public projects subject to the provisions of the Broadway Streetscape Master Plan include all improvements in the public right-of-way.

Private projects subject to the provisions of the Broadway Streetscape Master Plan are those which are regulated by the City or which require approval by the City Engineer for an A-Permit, Revocable Permit, B-Permit, E-Permit or U-Permit issued by the Department of Public Works. These permits are required for all street furniture, temporary and permanent signs, and any other addition to the public right-of-way. A project should be consistent with both the general streetscape standards of the City of Los Angeles and the Broadway Streetscape Master Plan as a condition of approval.

### Project Approval and Permits

Private implementation of streetscape components must be approved by the City, often by different bureaus or departments. City agencies can also assist private implementation of streetscape projects through their design expertise, the approval process, or even the availability of possible funds through state and federal grants. Refer to Chapter 5, Materials Palette and Location Criteria, for approval procedures and requirements for all City Departments and Bureaus that approve each streetscape component. Contact each one for their specific approval, procedures and requirements.

### Department of Public Works

**Permits** Streetscape project approval results in the issuance of a permit by the Department of Public Works. By approving the Broadway Streetscape Master Plan, the Board of Public Works has adopted the guidelines and standards contained in the plan as its own policies. This means that besides general City standards that apply to streetscape projects, each project will be reviewed for consistency with the Streetscape Master Plan as a condition of approval and permitting by the Department of Public Works. Different types of permits are issued for Streetscape projects, each with varying levels of review:

**A-Permit** The A-Permit is the first level of street improvement permits and is issued over the counter by Department of Public Works staff. Items typically permitted through this type of review are new or improved driveways and sidewalks. A nominal fee may be charged for plan check, filing, and inspection.

**Revocable Permits** Revocable Permits are the second or mid-level of street improvement permits. Projects requiring approval through the Revocable Permit process include improvements within the public right-of-way that do not change the configuration of the street. Revocable permit applications require the submittal of professionally prepared drawings on standard City (Bureau of Engineering) drawing sheets and are reviewed by the various Bureaus within the Department of Public Works for safety and liability issues. Revocable Permits are temporary permits. However, the City may revoke the permit at any time and for any reason. Improvements approved through the Revocable Permit process are maintained by the permittee. Failure by the permittee to keep the improvement in a safe and maintained condition allows the City to revoke the permitting rights, at which point a permittee is requested to restore the street to its original condition. A moderate fee is assessed for plan check, administrative filing, and inspection. The applicant is typically required to provide proof of liability insurance.

**B-Permit** The B-Permit process is reserved for streetscape Projects requiring the highest level of review. Approval through the B-permit process is required for projects that are permanent in nature and developed to a level that allows the City to maintain the improvement permanently. A B-Permit is usually issued for improvements that change the configuration of the street, traffic patterns, or other substantial permanent changes to the streetscape. Projects subject to the B-Permit review process require professionally prepared drawings submitted on standard City (Bureau of Engineering) drawing sheets and are reviewed by all public agencies affected by the improvements. A fee commensurate with the level of development is assessed for plan check, administration, and inspection. Construction bonding is required to ensure that the improvements are installed, and appropriately insured.

**E-Permits and U-Permits** Excavation Permits (E-Permits) and Utility Permits (U-Permits) are issued to allow construction, inspection, maintenance, repair, abandonment or removal of facilities that require vertical boring, horizontal boring, directional boring, trenching, or excavation in the public right-of-way. Examples of projects permitted under an E-Permit or U-Permit include construction work related to the relocation of a utility box, the relocation of a streetlight, the drilling of monitoring wells, and test boring to locate substructures. Excavation on private property adjacent to the public right-of-way may also require an E-Permit to ensure adequate lateral support of the public right-of-way. Failure to check the impact of excavation on private property relative to the public right-of-way could lead to the undermining and failure of the sidewalk or street pavement. The E-Permit and U-Permit may be issued in conjunction with an A-Permit (minor street construction), or with a B-Permit (major street construction). The purpose of these permit processes is to ensure that excavation work complies with the City's design and material specifications and that construction work is properly inspected. Consistent with this Streetscape Plan, each E-Permit and U-Permit recipient will be responsible for in-kind replacement of any damaged streetscape elements that may be affected by such work.

**Shop Inspection** All projects in the public-right-of-way are subject to Shop Inspection by the Department of Public Works, Bureau of Contract Administration. This requirement applies to major and minor projects, including construction of bus shelters, benches, bike racks, gateway monuments, newsracks and permanent signs in the public right-of-way. The purpose of this inspection is to assure quality in materials and construction. All Streetscape Project Plans should include a note with the following text:

*“Shop Fabrication should be made only from approved shop drawings and under inspection by the Bureau of Contract Administration. To arrange for inspection, call (213) 580-1392 two (2) weeks in advance for items more than fifty (50) miles outside of the City of Los Angeles, and 24 hours in advance for others.”*

### **Department of City Planning**

**Review** Review of streetscape projects by the Department of City Planning, including the Office of Historic Resources, is required for any streetscape projects located in designated historic districts or affecting existing historic resources. Other streetscape projects shall be reviewed by the Department of City Planning when the streetscape project includes any of the following streetscape components:

- Curb Extensions
- Crosswalks
- Paving
- Transit stop locations
- Directional and informational signage
- Color and materials for all LADOT hardware (e.g. controller boxes)
- Signs, including directional and informational signage

### **Document Submittal Requirements**

Conceptual Plans

- One set of plans identifying type and placement of proposed streetscape components.
- If streetscape components already exist within the plan boundaries, the set of plans should identify existing components and those proposed to be removed.

Photographs (as applicable)

- Subject site
- Existing streetscape components
- Proposed streetscape components

### **Department of Transportation**

**Review** Review by the Department of Transportation is required for the following streetscape components:

- Median strips
- Crosswalks
- Bus stop locations
- Directional and information signage
- Color and materials for all LADOT hardware (e.g. controller boxes)
- Interagency coordination for all MTA projects
- Bicycle racks and other bicycle facilities

---

## Implementation

The implementation of the Broadway Streetscape Master Plan is to occur over time as new projects, both publicly and privately financed, are approved for the plan area. Examples of public agency streetscape investments include improvements by the City of Los Angeles through its Department of Public Works and other governmental agencies, such as the Metropolitan Transportation Authority. Examples of private streetscape investments include improvements made by the local Business Improvement Districts (BID), grants or assessment districts, or by private developers proposing projects in the plan area. Implementation can also occur through approval of private projects consistent with the Broadway CDO, with the Department of City Planning imposing conditions implementing various sections of the Streetscape Plan, or through public improvement projects by non-profit community groups or individuals.

## Maintenance

Successful implementation of this Streetscape Master Plan requires not only that its standards be enforced, but that all approved projects be maintained. All proposed streetscape projects should include a maintenance plan. Such plans should be included in any project submittal to the Department of Public Works. Issues to be addressed include graffiti abatement, vandalism, irrigation repair and replacement including water billing responsibility, maintenance of landscape, trash collection for receptacles not emptied by the City, and any other maintenance tasks identified by the Department of Public Works.

## Plan Components and Organization

The physical reconfiguration of Broadway outlined in Chapter 4, Streetscape Plan, drives the future application of the materials palette, or “kit of parts,” and design and location criteria contained in Chapter 5, Materials Palette and Location Criteria. Chapters 4 and 5 are to be used together as a tool for the future application of the streetscape elements called for in this plan, and should be cross-referenced.

## 2.0 EXISTING CONDITIONS

### BROADWAY TODAY

#### Multiple Layers Over Time

The character of Broadway today is a product of the layering of multiple influences, applications of materials, styles, restorations, renovations and alterations, both in the public and private realms over time. It is at this intersection of the public and private realm that the experience of Broadway is defined. Storefronts expand their reach into the sidewalk, with signage displays, music, the smell of food, sales staff reciting today's deals, and, of course, merchandise. It is a rich streetscape experience in terms of activity.

As one of the most bustling pedestrian and bus corridors in Los Angeles, Broadway is filled with this activity – during daylight hours, that is. Many come to Broadway during the day from all around Los Angeles to shop, and many more come to catch a bus or transfer to another. However, at night, many of Broadway's storefronts lower roll-down security doors, lights go out, the buses are less frequent, and Broadway sleeps. Pools of harsh light illuminate empty streets, cars seeking overnight parking squeeze between bus loading zones, and not much happens. It is at night when the lack of activity resulting from a million square feet of vacant or underutilized space in Broadway's upper floors is most evident.

#### A Cultural Street

Beyond the complexity of Broadway as a hustle and bustle of pedestrians, buses, and cars against the backdrop of a rich tapestry of historic theatres and ornate building facades, is the function of Broadway as a cultural street. For decades, Broadway has been a place for performance, theatre, movies and cultural gathering; a place of commerce, for retail and shopping; a place for religious congregations and worship; and a place for parades, festivals, religious and cultural processions, and protest marches. As a cultural street, Broadway conveys these various activities often through procession, whether a parade from Broadway and Olympic to City Hall, or a family on a weekend shopping trip. It is this inherent pedestrian orientation and use that makes Broadway the street that it is, in the collective consciousness of Los Angeles. This deeply rooted cultural heritage is part of the historical Broadway experience that this Streetscape Master Plan seeks to support and enhance.



Some theatres have been converted to accommodate new uses over time.



Vendor kiosks offer newspapers and magazines and are part of the cultural streetscene.



Fiesta Broadway, an annual street fair celebrating Latino culture.



May Day 2006 Immigrant Rights March on Broadway.

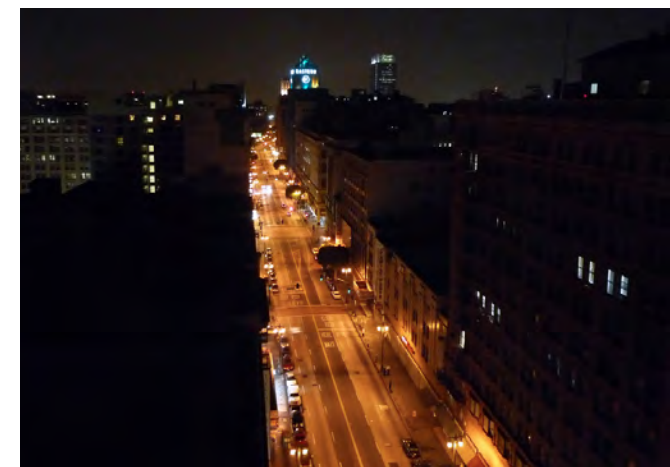

Sleeping Broadway with dark, underutilized upper floors.



Roll-down security doors obscure a number of storefronts during off hours.

## EXISTING HISTORIC & CULTURAL FABRIC

The Broadway streetscape contains a rich and varied array of historic fabric, some of which dates back to the earliest part of the 20th century. This Streetscape Master Plan focuses on the historic elements found within the public realm, such as paving and other elements found in sidewalks, but is also mindful of elements in the private realm, such as historic theatre marquees, historic building facades, flagpoles and signs atop buildings, and arcades and entryways.

An Historic Architectural Survey (HASER) completed in 1998 outlines elements of the Broadway streetscape that are considered “contributing elements” to the historic character of the corridor, and are thus protected from alteration, as this portion of Broadway falls within the Broadway Theatre and Commercial Historic District, established in 1986. The 1998 survey has been updated with the 2010 Supplemental Historic Property Survey Report (HPSR), conducted by Chattel Architecture, Planning and Preservation, Inc., and is included in the Appendix to this document. This HPSR does not identify any additional resources or contributing character-defining features. The features considered contributing include terrazzo paving and sidewalk vault lights (glass block). Although the “Broadway Rose” street light bases were identified in the HASER as contributing features of the historic district, The State Historic Preservation Office (SHPO), in a memo, disagreed with the finding. However, the HPSR acknowledges the historic quality and uniformity of the presence of the streetlight bases along the street. Further, vent covers are considered contributing elements, yet the HPSR recommends reconsideration due to their utilitarian appearance and haphazard placement. Refer to the HPSR in the Appendix to this document for a list of contributing elements within the public right-of-way in the project area, along with photos and locations.

Historic and cultural fabric taken into consideration for this Plan are described in detail below.

### “Broadway Rose” Streetlight Bases

Broadway is lined with regularly-spaced streetlights that still utilize a historic base installed in the 1920’s. Although the poles and fixtures of the street lights were replaced in the 1950s, the existing historic bases are consistent and are in relatively good condition. This Master Plan calls for keeping these existing historic bases in place. For more information on the strategy for street lighting on Broadway, see Chapter 4; for more detail on the streetlights themselves, see Chapter 5.

### Terrazzo

On Broadway, colorful terrazzo paving often serves as an outdoor foyer into the lavish movie palaces and theatres found inside. Terrazzo paving can also be found outside of the entrances to buildings, forming a utilitarian “mat” in front of a storefront or serving as an ornamental “tongue” extending out from a building entrance, to a highly decorative element carpeting the entire

sidewalk from the building face to the curb line to signify the reaches of the building’s facade.

The most prevalent form of terrazzo deterioration on Broadway is localized cracking. Other common problems are inappropriate patching and intrusion of water boxes, plate covers, electrical meters, and other infrastructure. Some areas exhibit more severe deterioration in the form of spalling.

As a historically significant and contributing element of the National Register Historic Broadway Theatre District, terrazzo paving found along Broadway from 2nd Street to Olympic shall be preserved and restored. See Chapter 5, Materials Palette and Location Criteria, along with the HPSR in the Appendix of this document, for a list of addresses for buildings with contributing historic terrazzo, a more detailed discussion on terrazzo along Broadway and helpful resources.

### Glass Block Basement Skylights

Many historic buildings along Broadway were originally constructed with basements that extend under the sidewalk, sometimes all the way to the curb. To provide daytime illumination to the basements, glass block skylights were installed in the sidewalk.

Problems with sidewalk vault light panels that exist along Broadway is their propensity for the glass to break and the assembly as a whole to leak, both in area of breakage and along edges of the panels. In addition, sidewalk vault light panels have not been maintained over the years. Many panels have been covered in whole or part in asphalt.

Glass block basement skylights are historically significant and contributing elements of the National Register Historic Broadway Theatre District, and as such shall be preserved and restored. See the HPSR in the Appendix of this document for more a detailed discussion on the restoration of glass block basement skylights (sidewalk vault light panels) along Broadway and helpful resources.

### Other Historic Streetscape Elements

Other public realm elements of Broadway are acknowledged as containing historic character, even though they are not considered official contributing elements, and are listed in detail in the Historic Architectural Survey (1998) and the Historic Property Survey Report (2010). These elements include hardware such as ventilation covers, metal basement hatch doors, utility covers, and flag pole holders. These elements should be identified and preserved where feasible when any aspect of the sidewalk is altered for sidewalk reconstruction, re-paving or general maintenance.



Existing “Broadway Rose” Streetlight Base; Historic photo of a 7-globe Llewellyn.

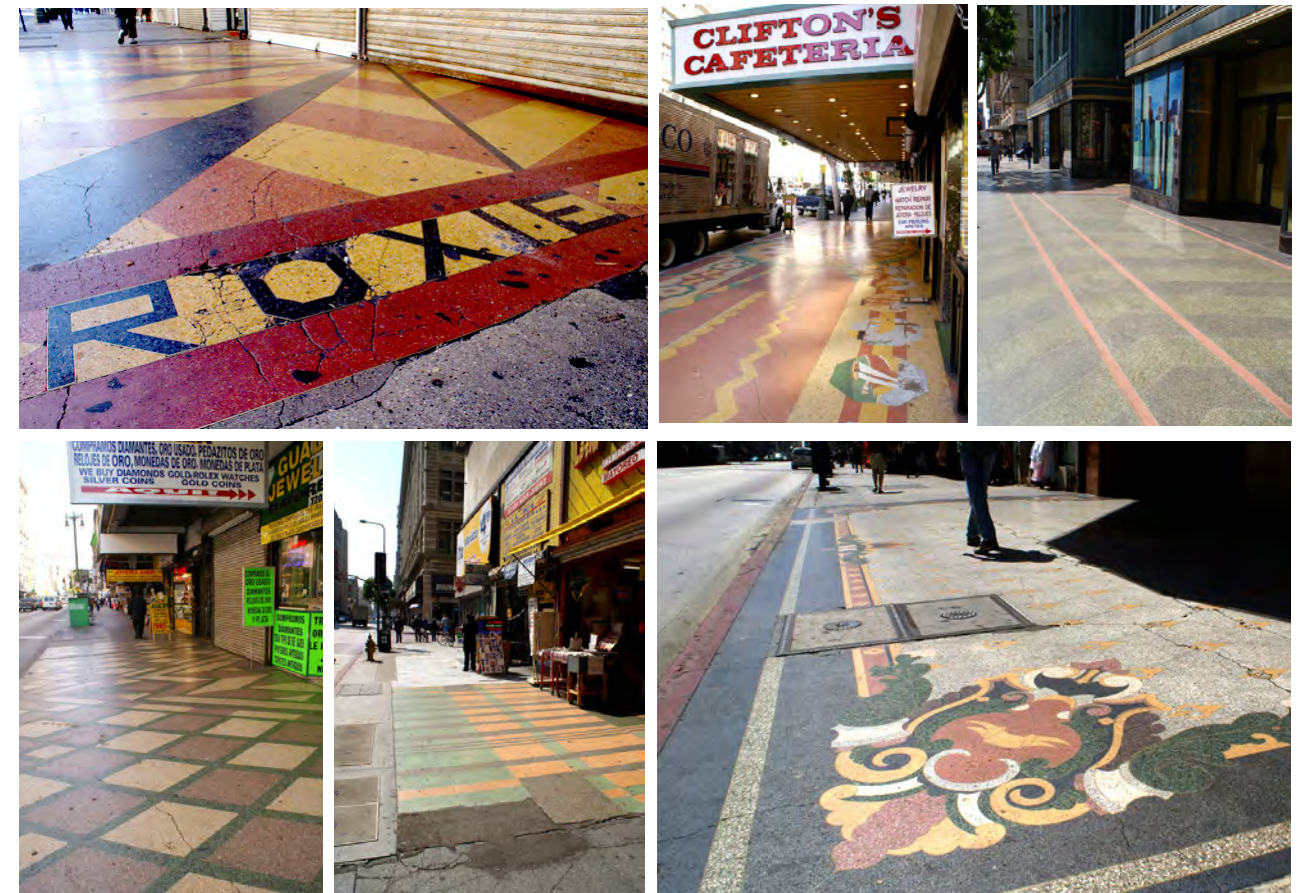

Examples of Historic Terrazzo in front of Historic Theatres and Buildings on Broadway, and in various states of disrepair. Some terrazzo serves as an entry statement, other carpets the sidewalk out to the existing curb following the building’s footprint.



Glass Block Basement Skylights provide daytime illumination to basements below. Many are in need of critical repair and restoration.



Historic Utility Covers



"Romero Tile" at 7th & Broadway

## Romero Tile

Although not an identified historic element, the sidewalk paving tile at Broadway and 7th Street, designed by artist Frank Romero and installed in 1984, is an element of cultural interest in the Broadway Streetscape. The Romero tile incorporates abstracted Mexican motifs in contrasting colored tile set in a field of brown tile. However, it is not a character-defining feature of the district as it was installed after the period of historic significance, and is not eligible for listing in the National Register as it does not meet the fifty year age requirement. Further review is needed to determine how to address this stretch of Romero tile if a proposal to remove it is put forward. For more information, see the Historic Survey (1998) and Supplemental Historic Property Report (2010) in the appendices to this document.

## EXISTING STREETScape ELEMENTS

A variety of streetscape amenities have been added to the historic fabric of Broadway over time, and differ from block to block. An existing conditions map cataloging existing streetscape elements in the project area is found in Figures 2-1 through 2-4. This map represents a visual survey of Broadway conducted in early 2009 and indicates general locations of streetscape elements for illustrative purposes only.

For a more detailed, technical catalog of existing streetscape features, see the Design Survey of Broadway Sidewalks conducted for the former CRA/LA in April of 2009 found in the Appendix to this document.



Figure 2-1: 2009 Existing Conditions Plan - Broadway from 2nd Street to 4th Street

**EXISTING STREETScape ELEMENTS**

- Street Light
- Street Light (w/ Traffic Light)
- Pedestrian Light
- Confirmed Existing Tree
- Empty Tree Pit
- Tree in Planter
- Bike Rack
- News Racks
- Newspaper/Magazine Kiosk
- Trash Can
- Bench
- Bus Stop
- Crosswalk (Mid-Block)
- Intersection Treatments

**EXISTING HISTORIC FABRIC**

- Terrazzo
- Colored Concrete
- Glass Block
- Basement Access Hatch
- Basement Locations Underground
- Historic Theatres
- Historic Buildings (Nat'l Register)

**OPEN SPACE & OPPORTUNITIES**

- Pedestrian Paseo Opportunity
- Existing Open Space/Paseo
- Surface Parking
- Parking Structure/Garage
- Metro Rail Station

**UTILITIES**

- Fire Hydrant
- Curb Cut

**EXISTING SIGNAGE**

- Radio Tower
- Vehicular Directional
- Pedestrian Directional
- District Marker ID
- Route 66
- Information Kiosk
- Historical Area Map

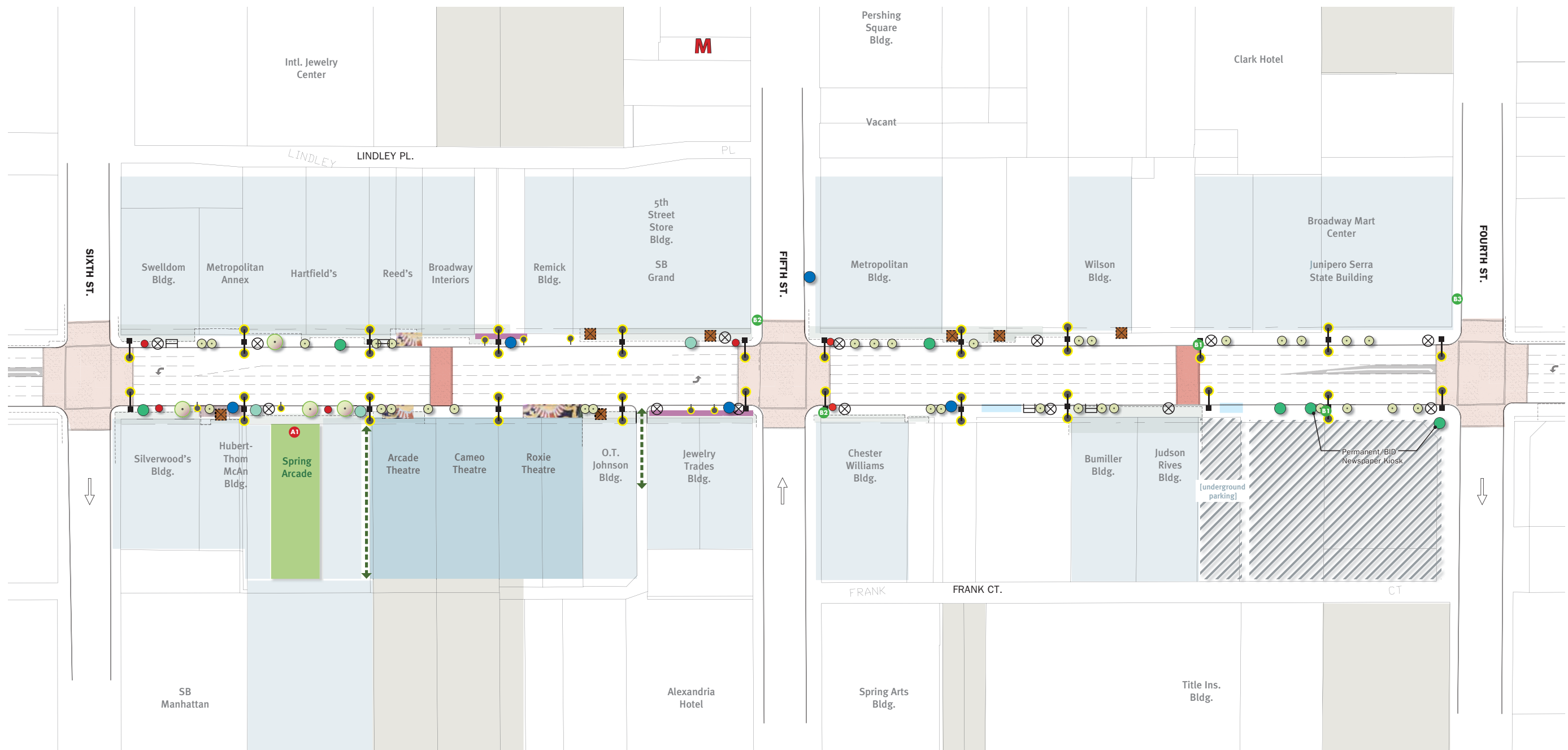

Figure 2-2: 2009 Existing Conditions Plan - Broadway from 4th Street to 6th Street



**EXISTING STREETScape ELEMENTS**

- Street Light
- Street Light (w/ Traffic Light)
- Pedestrian Light
- Confirmed Existing Tree
- Empty Tree Pit
- Tree in Planter
- Bike Rack
- News Racks
- Newspaper/Magazine Kiosk
- Trash Can
- Bench
- Bus Stop
- Crosswalk (Mid-Block)
- Intersection Treatments

**EXISTING HISTORIC FABRIC**

- Terrazzo
- Colored Concrete
- Glass Block
- Basement Access Hatch
- Basement Locations Underground
- Historic Theatres
- Historic Buildings (Nat'l Register)

**OPEN SPACE & OPPORTUNITIES**

- Pedestrian Paseo Opportunity
- Existing Open Space/Paseo
- Surface Parking
- Parking Structure/Garage
- Metro Rail Station

**UTILITIES**

- Fire Hydrant
- Curb Cut

**EXISTING SIGNAGE**

- Radio Tower
- Vehicular Directional
- Pedestrian Directional
- District Marker ID
- Route 66
- Information Kiosk
- Historical Area Map

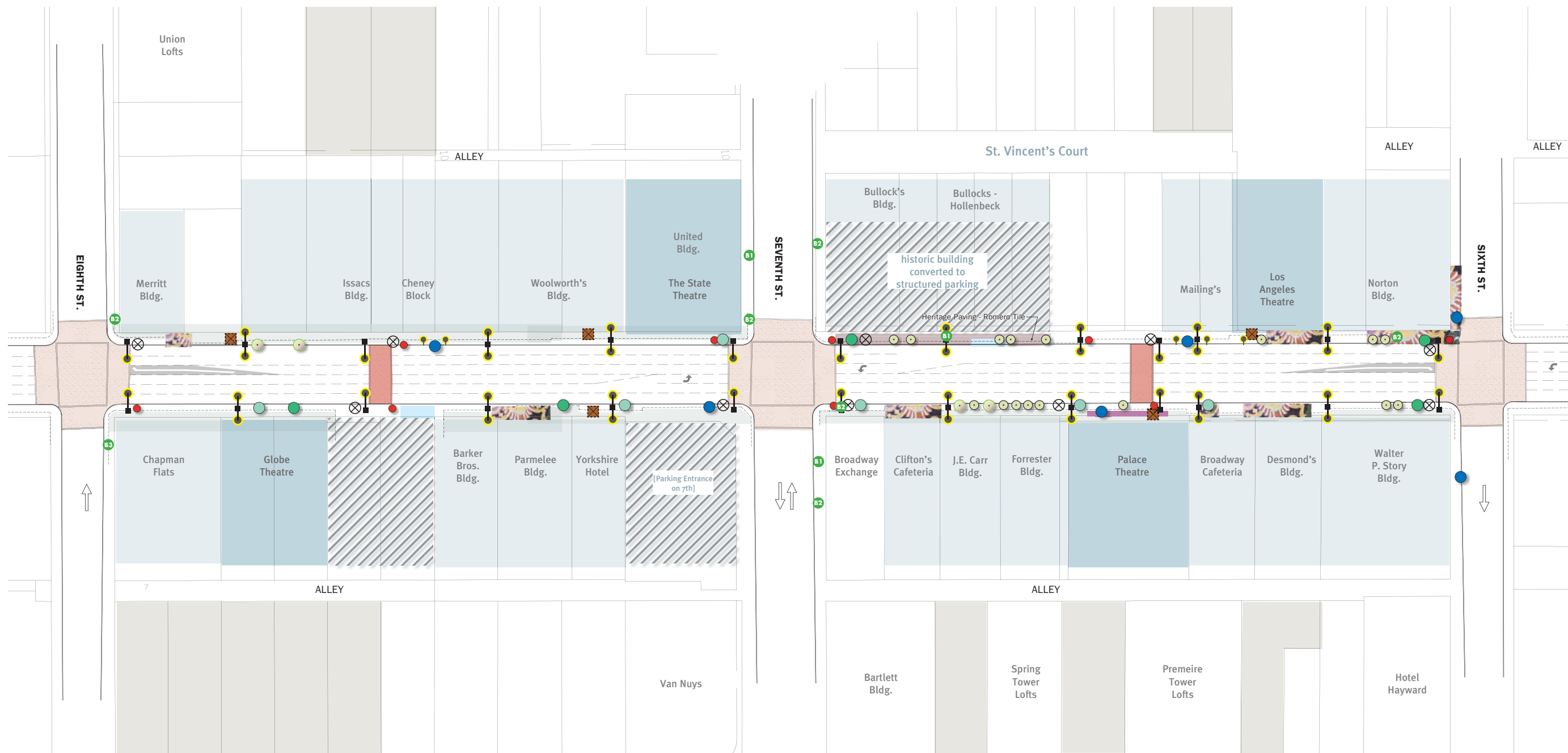

Figure 2-3: 2009 Existing Conditions Plan - Broadway from 6th Street to 8th Street

**EXISTING STREETScape ELEMENTS**

- Street Light
- Street Light (w/ Traffic Light)
- Pedestrian Light
- Confirmed Existing Tree
- Empty Tree Pit
- Tree in Planter
- Bike Rack
- News Racks
- Newspaper/Magazine Kiosk
- Trash Can
- Bench
- Bus Stop
- Crosswalk (Mid-Block)
- Intersection Treatments

**EXISTING HISTORIC FABRIC**

- Terrazzo
- Colored Concrete
- Glass Block
- Basement Access Hatch
- Basement Locations Underground
- Historic Theatres
- Historic Buildings (Nat'l Register)

**OPEN SPACE & OPPORTUNITIES**

- Pedestrian Paseo Opportunity
- Existing Open Space/Paseo
- Surface Parking
- Parking Structure/Garage
- Metro Rail Station

**UTILITIES**

- Fire Hydrant
- Curb Cut

**EXISTING SIGNAGE**

- Radio Tower
- Vehicular Directional
- Pedestrian Directional
- District Marker ID
- Route 66
- Information Kiosk
- Historical Area Map

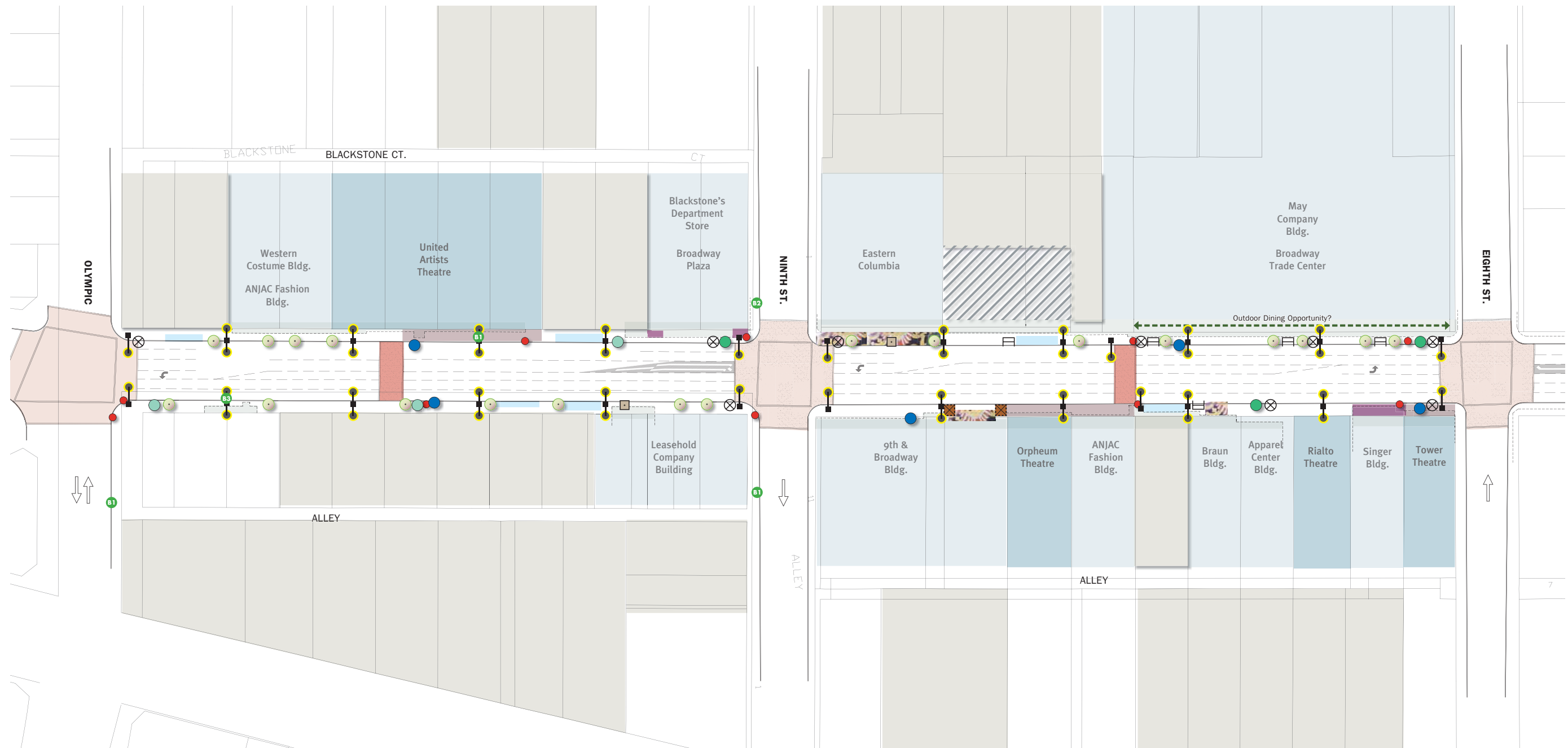

Figure 2-4: 2009 Existing Conditions Plan - Broadway from 8th Street to Olympic



**EXISTING STREETScape ELEMENTS**

- Street Light
- Street Light (w/ Traffic Light)
- Pedestrian Light
- Confirmed Existing Tree
- Empty Tree Pit
- Tree in Planter
- Bike Rack
- News Racks
- Newspaper/Magazine Kiosk
- ⊗ Trash Can
- ⊞ Bench
- Bus Stop
- Crosswalk (Mid-Block)
- Intersection Treatments

**EXISTING HISTORIC FABRIC**

- Terrazzo
- Colored Concrete
- Glass Block
- Basement Access Hatch
- Basement Locations Underground
- Historic Theatres
- Historic Buildings (Nat'l Register)

**OPEN SPACE & OPPORTUNITIES**

- ↔ Pedestrian Paseo Opportunity
- Existing Open Space/Paseo
- Surface Parking
- ▨ Parking Structure/Garage
- M Metro Rail Station

**UTILITIES**

- Fire Hydrant
- Curb Cut

**EXISTING SIGNAGE**

- A1 Radio Tower
- B1 Vehicular Directional
- B2 Pedestrian Directional
- B3 District Marker ID
- B4 Route 66
- C1 Information Kiosk
- C2 Historical Area Map

## Landscape Elements

### Street Trees

Street tree planting is irregular along Broadway from 2nd to Olympic, with concentrations of trees at either end of the corridor. There is no consistent street tree species found along Broadway. Significant constraints to tree planting exist along the corridor, including basements that extend in many places out to curb lines, as well as underground utilities running directly along the curb. These constraints are discussed in more detail below. The street trees that are found along Broadway have been planted since the 1960s, and as such, are not considered historic character-defining features of the street.

Some smaller trees of varying species have been introduced above ground in large pots in recent years along portions of the corridor.

### Paving

#### Sidewalks

In addition to the historic terrazzo and glass blocks described above, Broadway's sidewalks consist of a variety of materials, some considered fundamental to the historic character of the street, and catalogued in the Historic Survey as well as discussed above. Sidewalk paving is inconsistent and varied, as well as deteriorated and in disrepair on Broadway. Some portions of Broadway have been recently paved, as sidewalk reconstruction has been completed, including portions of blocks between 3rd to 5th Streets. Stains from years of wear and tear, not to mention the spots from discarded chewing gum, has left natural colored concrete with a worn look over time.

#### Crosswalks

Paving at intersections consists of red integral-colored concrete, stamped with a faux-brick pattern. All of the mid-block crossings on Broadway contain this same stamped red integral color concrete treatment.



Trees of varying species are found sporadically and inconsistently along Broadway, some planted in ground, others in coordinated planters reading "Historic Downtown Los Angeles."



Some Sidewalk paving along Broadway has been laid in recent years, other shows its age. Other materials aside from concrete have been used, and are patched with asphalt.



Crosswalks at Intersections and Midblocks have red integral colored concrete with a faux brick imprint pattern. Interior fields of intersections also have red integral colored concrete.

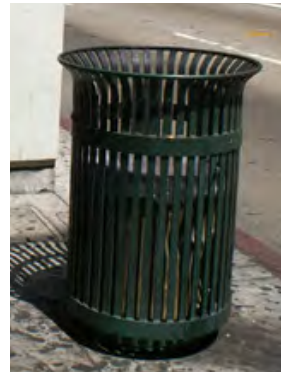

Benches are placed far from activity centers and are not accompanied by shade. Trash cans are for the most part coordinated, and located generally at midblock crossings and intersections. Bike racks are not located consistently, mainly placed between 2nd to 4th Streets, and are the standard LADOT u-shaped rack. Newspaper racks are uncoordinated, and sometimes placed near bus stops, causing conflicts for passengers entering and exiting buses.



Bus stops along Broadway, both for Metro Local and Rapid service, do not provide consistent furnishings other than route signage.



Vendor kiosks along Broadway can be found on almost every block, and are part of the shopping tradition of the street. Kiosks are either made from plywood and painted green (above left), or City-issued products (above center). Many utilize umbrellas or tarps to provide shade on sunny days.

## Furnishings

### Bus Stops

Currently there are no bus shelters on Broadway. Bus stops are generally clear of furnishings, except for pedestrian safety lighting fixtures installed by Metro.

### Benches and Seating

Benches are found sporadically along Broadway. Most are cast iron. Use of informal seating opportunities can be observed along the corridor, specifically the steps to the building on the southwest corner of 8th Street and Broadway, where passengers waiting for the bus find shade and places to sit under the awning of the building and along the steps that lead up to the storefronts.

### Trash Receptacles

Trash receptacles are generally located at intersections and midblock crossings.

### Bike Racks

There are a few LADOT standard bike racks installed along Broadway north of 4th Street, and a custom bike rack in front of Grand Central Market at 3rd Street.

### News Racks

Newspaper racks are sporadically located along Broadway, with no discernible pattern. They are sometimes located near bus stops, causing conflicts for passengers entering and exiting buses.

### Tree Grates

Some trees along Broadway are planted in decomposed granite, some have asphalt or concrete covering their roots, and others are in tree wells covered with grates of varying designs and sizes.

### Pots/Planters

Particularly between 4th to 7th Streets, small tree species are planted in pots on Broadway. The pots, paid for and maintained by the local Historic Downtown Business Improvement District (BID), are square and painted light green.

### Vendor Kiosks

The City of Los Angeles sponsors a vendor program, issuing licenses to individual vendors to sell magazines and other publications. Numerous dark green small wooden or sheet metal structures, are found along Broadway selling a variety of magazines and publications. Many kiosk vendors attach umbrellas or tarps to the top of the structures for shade. Where sidewalks have been repoured and basements restored underneath them, providing a foundation for them, the current City standard heavier weight kiosk has replaced the older structures.

## LIGHTING

### Street Lighting

Existing street lights along Broadway are regularly spaced at 120' apart on average. Cobra heads attached to traffic light poles provide illumination at intersections.

Broadway's first lighting system (c.1905 - c.1918) consisted of Llewellyn 7-light poles. Broadway's second lighting system (c.1918 - c.1948) introduced the Broadway Rose with 'Spanish Renaissance' bases at intersections and 'Rose' bases at mid-block locations. These bases contain ornate floral and vine detail on all four sides. In the 1940s the original poles were replaced with taller poles and pendant fixtures to provide greater levels of illumination for the roadway. The 'Spanish Renaissance' bases were incorporated into the new poles.

Currently, each street light along Broadway, except those at intersections, contains unique historic fabric within the bases of the poles, original to the street. Although the bases are not considered by the State Historic Preservation Office (SHPO) to be contributing historic elements, they are regarded as worth incorporating into the streetscape, and will be preserved and restored (see previous discussion in this chapter).

### Pedestrian Lighting

There is no pedestrian-scale lighting along Broadway, except for the occasional bus stop safety light installed by Metro at various bus stops along the corridor.

### Facade Lighting

Nighttime illumination of the many theatre marquee signs and building facades along the street contribute to the lighting of the public realm, even though these elements exist within the private realm. Many stretches of Broadway appear dark, with underutilized upper floors and businesses that are active mostly in the day time. However, the Historic Downtown Business Improvement District (HDBID) created a master plan for lighting private building facades along Broadway and Spring Street that offers guidance for property owners seeking to enhance the illumination of their building and the public right of way in turn. For more information see the *Building Facades Lighting Plan for the Historic Downtown Los Angeles Business Improvement District (2005)* in the Appendices of this master plan.



Existing streetlight on Broadway (left); detail of its ornate historic base (center); existing pedestrian-scale safety light at a Metro bus stop (right).

## PUBLIC SIGNAGE

## PRIVATE SIGNAGE

## WAYFINDING, INFORMATION & IDENTITY

Existing public realm signage along Broadway is a mixture of many different types, some oriented to the driver, some to the pedestrian, and are controlled by many different entities. Each individual signage type may be consistently applied to the corridor, but as a whole, signage is for the most part uncoordinated. A catalog of existing wayfinding, information and identity elements is shown in Figure 2-5.

### Identity

Existing identity signage includes signs that identify the corridor, are iconic in nature, and let the visitor know they have arrived at a particular destination, such as the KRKD radio tower above the Broadway-Spring Arcade Building, theatre marquees and blade signs, and retail blade signs. Although these signs exist in the private realm, they are some of the most character defining signage on Broadway, and are considered here to understand the full array of elements contributing to the existing condition of signage on Broadway.

### Direction

Existing directional signage includes signs that direct a visitor to various destinations along and near the Broadway corridor, serving a general wayfinding function, including vehicular and pedestrian directional signage.

### Information

Existing information signage includes signs that provide detailed information to the visitor, such as district area maps and history kiosks. Although somewhat consistently located, existing pedestrian-scale and transit user-oriented wayfinding signage is unpredictable and difficult to locate from key locations, and is typically inaccessible from eye level at the sidewalk. Pedestrian-oriented maps of historic downtown are attached far above eye level on streetlight posts at intersections and offer locations of, and routing to, just a few of the many destinations and attractions in the area. Bus stops offer no destination or route direction information beyond the standard Metro signage identifying route numbers.

### Regulation

Existing regulatory signage, such as parking/loading regulation signs, which are required by accessibility and local codes, can be overwhelming.

### Amenities

Existing site beautification elements, including public art and street furnishings, are largely uncoordinated. However, a strong presence of artistic murals can be found on Broadway, such as the Victor Clothing Co. building.

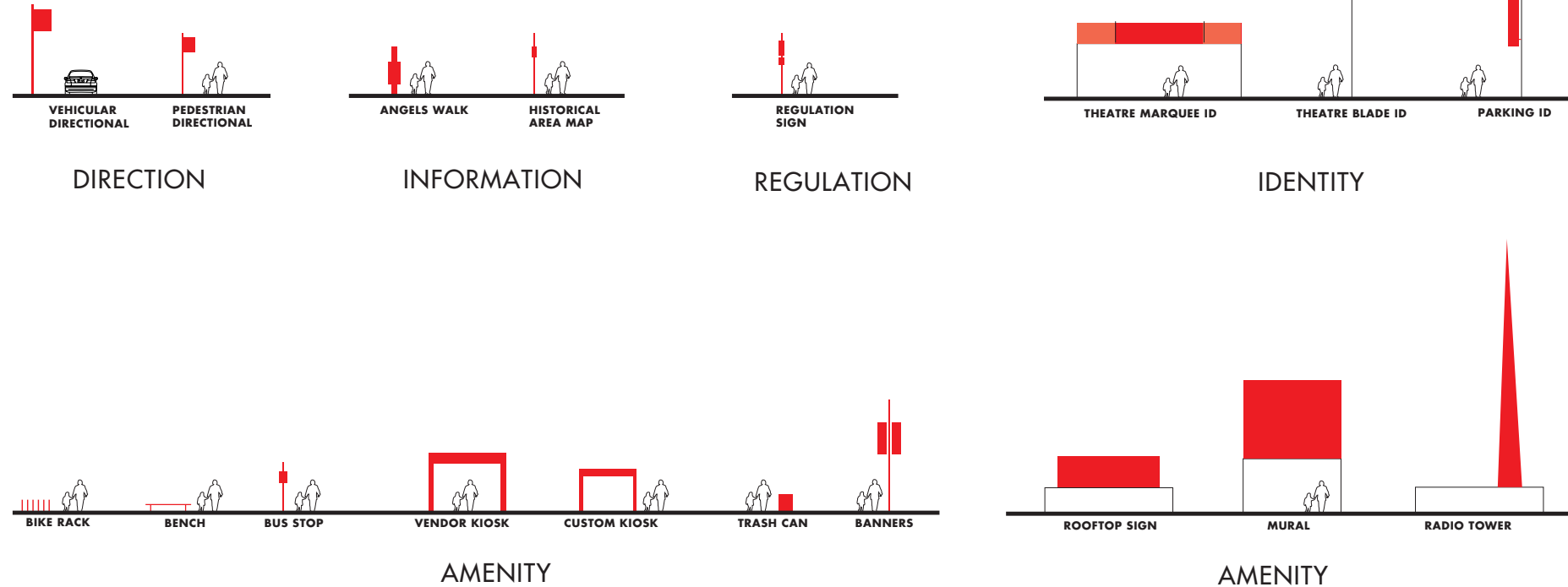

Figure 2-5: Existing Wayfinding, Information and Identity Elements



Examples of existing public realm signage on Broadway.

## OTHER BROADWAY ISSUES

### Basement Structural Issues

With much of Broadway's infrastructure and construction dating back to the early 1900s, many buildings contain basements stretching out from property lines under the sidewalks, some all the way to the existing curb (underground basements are conceptually depicted on Figures 2-1–2-4). After many long years of use, a great number of basements are in serious states of disrepair and deterioration as a result of moisture penetrating the glass block skylights. (For full reports, see Structural Investigation of Sidewalks Along Broadway in the appendix to this document.)

At the surface, sidewalks are also in varying states of disrepair, with evidence of haphazard patching of cracks that point to structural problems underneath. Structural safety and aesthetic issues exist along these sidewalks, with 14 basements within the project area identified as in need of repair. Historically significant glass inserts forming the skylights for the basements below are in various degrees of disrepair as well.

Over the years, much damage has been sustained to the underlying infrastructure. This has resulted in severe corrosion of the steel beams, reinforcing bars and pressed metal forms that span below the sidewalk.

While these conditions should be considered a high priority for the City and reconstruction of deteriorating infrastructure should be encouraged, the implementation of the Broadway Streetscape Master Plan is not contingent upon the completion of those repairs. Because of the nature of the Streetscape Plan which expands into the existing roadway with new construction, the Streetscape Plan is a stand-alone project not impacted by the existing conditions of the current infrastructure.

### Pedestrian Safety

Broadway is a pedestrian-rich corridor with heavy, and oftentimes fast-moving, vehicular and bus traffic and a 56-foot curb-to-curb crosswalk distance east-west. Pedestrians encounter significant difficulty in safely crossing Broadway, a problem which is magnified for the elderly, for pedestrians with mobility impairments, and for those carrying large items or pushing strollers, etc. Buses and motor vehicles also travel at high speeds through intersections and between traffic signals, directly along curb lanes. Pedestrians standing at intersections or walking along the sidewalk currently have no buffer from buses and vehicles traveling along Broadway.

There are, however, mid-block crossings on each block of Broadway within this Plan's project area, except for the block between 2nd and 3rd Streets. These pedestrian-actuated flashing crossings are not immediate and are set on a timer to work with the existing intersection signalization patterns; pedestrians must wait until the walk signal illuminates after pushing the button.

### Existing Utilities

Another constraint for future improvements to Broadway are the underground utilities that run outboard of both east and west curbs underneath the existing roadway. (Please refer to the April 2009 Design Survey for Broadway Sidewalks in the Appendix to this document for general types and locations of underground utilities.) This utility zone poses constraints for tree planting, as well as for how to accommodate restored streetcar service, as tracks can not be laid above this zone, causing costly utility relocation.



Most basements are in a serious state of deterioration, which can be seen both above and below ground.



Pedestrians currently wait at the edge of curbs with cars and buses traveling at sometimes high speeds along the curb lane. There is no buffer, such as consistent on-street parking or loading zones, between pedestrians and vehicular traffic.

## 3.0 VISION & DESIGN PRINCIPLES

### WHAT IS A VISION?

Fundamental to any plan is a vision, or an overtly expressed statement of a collectively desired future condition. A plan for future change must have a clear sense of vision to motivate accomplishment, focus effort, leverage investments of time and resources, and sustain commitment over time. Especially, this vision must unify all those involved around key themes that enable the realization of this collective aspiration.

### THE VISION FOR BROADWAY

After a 9-month public process, engagement of Bringing Back Broadway stakeholders, and meeting with relevant City and Agency staff, a vision has emerged for Broadway's future. This vision articulates not just what Broadway's streetscape will look like physically, from an urban design perspective, but also how Broadway will function to serve its myriad users, including visitors, workers and residents. It is supportive of the restoration of historic streetcar service, but is not dependent on it. It connects Broadway's past to the present and its future. And it does so with a reverence and respect for the rich historic and cultural fabric of the street. This vision asks us all to "peel away the layers" that have been added over time to reveal its full potential and allow Broadway to reemerge as one of Los Angeles' preeminent multi-modal thoroughfares.

### An American Brand

The Broadway Historic Theatre District – with its unique history, rich architecture and urban fabric – distinguishes and differentiates Broadway from other streets in Downtown Los Angeles. It is the inspiration and touchstone for this Streetscape Master Plan.

Broadway, as a concept, is uniquely American. It is an original American Brand. Broadway, as a place, is synonymous with "Theatre District" or "Entertainment District." To be "on Broadway" is to be part of Entertainment, Theatre, Movies, Glamour, Crowds, Lights, Movement, Excitement, Creativity and Energy.

Broadway, as a term, has national and international name recognition. The term "Broadway" itself, and the entertainment use and glamorous history it conjures, is the link between the past, present and future of this District.

### Peeling Away the Layers

Bringing Back Broadway, within the streetscape of the public realm, doesn't mean inventing a new story or new imagery to take Broadway in a new visual direction. It does mean pulling away the layers that have been added to Broadway that obscure its true grandeur, unifying the street design, and providing a new supporting cast of amenities which complement, enhance, and draw attention to the star of the show, Broadway's historic fabric.

The Streetscape Master Plan, and the design it will guide, seeks to:

- tell the street's many and varied stories and celebrate its past
- improve the street's image by clearing away the clutter, restoring the light and luster of the district, using consistent, high quality, elegant materials, and enhancing function and comfort
- draw visitors to Broadway, and enhance its appeal for its many stakeholders – not only those in the entertainment industry still here today together with the creative arts communities, but also residents, workers and retailers
- accommodate future change and evolution, in land uses, in activities on the street, and in transportation systems serving the street



**Broadway (Dictionary.com)** - Broad way [brawd-wey]

–noun

1. a street in New York City, famous for its theaters, restaurants, and bright lights.

**2. the theater district located on or near this street, esp. as the center of the professional or commercial theater in the U.S.**

–adjective

3. (of a play, theatrical performance, etc.) pertaining to, suitable for, or produced in the commercial theater, esp. on Broadway: a Broadway show.

4. acting or working on Broadway: a Broadway producer; a Broadway star.

**5. characteristic of or frequenting the theater district on Broadway.**



**Broadway** New York, NY



**Broadway** Los Angeles, CA

## DESIGN PRINCIPLES

The design principles outlined below provide the foundation upon which this Streetscape Master Plan was developed. These principles are the central, guiding themes that permeate each design choice and expression. They are the touchstones of the project vision, or the criteria by which the elements of this Plan were developed in order to satisfy the aspirations of the community, Broadway stakeholders, and City and Agency staff.

### Keep It Simple

Incorporate clean, modern furnishings and materials, and locate them consistently on Broadway, allowing the historic features (architecture, terrazzo paving) of the buildings to be the star of the show.

### Avoid Historic Recreations

There's already a sense of place on Broadway. Streetscape design elements are secondary to, and must honor, the historic fabric and character of the street.

### Strive for High Levels of Transparency

For safety as well as aesthetics, streetscape elements promote visual transparency, preserving views of historic architecture and not contributing to visual clutter on Broadway.

### Create and Highlight Pedestrian Connections

Paseos, alleys, walkways, open spaces, nearby destinations and transit links are connected and called out through materials and wayfinding elements.

### Enhance the Perception of Safety

Provide pedestrian-scale lighting as well as facade lighting to increase perception of nighttime safety and encourage foot traffic on Broadway. Improve crosswalks at intersections and midblocks to ensure pedestrian visibility and shorten crossing distances. Buffer pedestrians from street traffic.

### Lay the Foundation for a Timeless Streetscape

Broadway Streetscape improvements are of flexible design and/or modular construction to serve both the current and future needs of the street.

### Create an Environmentally Responsible Design

Utilize low-energy sources and alternative energy sources, as feasible in lighting. Seek to capture and cleanse stormwater runoff. Specify furnishings and materials that include recycled content.

Accommodate a Multi-Modal Transportation System - Plan to accommodate a streetcar on Broadway, as well as Metro buses, autos and delivery vehicles.

### Stimulate Private Sector Investment

Streetscape improvements should be a catalyst for private investment by improving the public realm, establishing a new identity for the District, and creating a contrast with inconsistencies in existing private development.



**Keep** it simple



**Strive** for Transparency



**Enhance** Safety



**Be** Environmentally Responsible



**Create** Connections



**Lay the Foundation** for a Timeless Streetscape

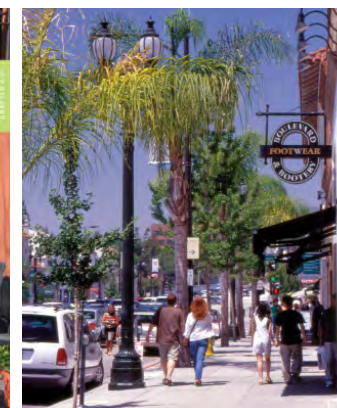

**Accommodate** a Multi-Modal System



**Figure 3-1A: Visualization of Preferred Configuration – 3 lanes: 1 Southbound, 2 Northbound**

Looking North from Intersection Toward a Transit Station

## OTHER FUNDAMENTAL CONSIDERATIONS

There are other considerations fundamental to the development of this Streetscape Master Plan that may answer many of the “did you consider this?” or “what about this?” questions one may have while digesting this ambitious Plan. Some of these considerations are constraints that were priorities to solve, others were opportunities that were priorities to seize. Still others were new ideas that when introduced to Broadway will further enhance the basic improvements that any plan would address. This Plan goes beyond constraints and opportunities and elevates the discussion of what Broadway will be with a thorough look at all issues, augmented by fresh approaches that are rooted in a respect for what Broadway is. See Figures 3-1A and 3-1B for conceptual illustrations of the vision for Broadway.

### Mobility

This Plan seeks to prioritize the pedestrian and the transit user over the private automobile. Focusing on people first is a re-conceptualization of mobility itself, especially for a major thoroughfare in Los Angeles. Instead of seeing an efficient street as one that moves a certain number of vehicles through its intersections at certain target speeds, or one that maximizes throughput, this Plan seeks to move people both through *and along* the street, in a *multi-modal* fashion, in order to achieve efficiency and maximize input and output, be that by bus, bike, streetcar, delivery truck, or car.

Broadway is one of the most transit-rich streets in Los Angeles, with 12 individual Local and Rapid Metro Bus Lines serving the street, not to mention the multitude of connections to Metro and Municipal bus and Metro Rail lines within a 5-10 minute walk. Considering the proposed addition of the restoration of historic streetcar service on Broadway, and the needs of business owners for parking and loading, the street is complex in terms of mobility.

By prioritizing the pedestrian and transit user over the private automobile, the balance is rendered in such a way as to create a safer, more humane environment for the resurgence of the gems of this historic corridor.

### Configuration

The reconfiguration of Broadway to accommodate multi-modal transit service was another consideration in the development of this Plan. Universal design and accessibility regulations require a curb for loading passengers served by the many bus lines that currently traverse Broadway. This street design will also complement the planned restoration of historic streetcar service, should that plan be implemented, which calls for a southbound, curbside-running route on Broadway. Exploring changes to the configuration of Broadway offered a chance to reconsider traffic lanes, sidewalk widths, and other physical design features of the street. A reconfiguration of Broadway allows for the shifting curbs to not only widen sidewalks, providing for more pedestrian amenities and better pedestrian flow, but also to serve southbound-running, curbside-loading, and ADA compliant transit/

streetcar service on the West side of Broadway. See Chapter 4 for an in-depth discussion on the ideas, design alternatives and other information that went into determining a community-preferred configuration for Broadway.

## Green Streets

This Plan seeks to incorporate sustainable design practices throughout Broadway, not only for the sake of environmental consciousness, but because doing so will ensure a timeless streetscape that can convey stormwater and handle energy in ways that promote conservation and efficiency. Storm water and urban runoff will be captured and filtered through planters in curb extensions as well as new tree wells, and cleansed before discharging back into the storm drain system. Streetlights may utilize LED technology that will reduce energy demands. Street trees will shade paved areas, reducing the heat island effect. Overall, this Plan looks to new technologies to carry this historic corridor into modern times prepared for a resource-conscious future.

Sustainable design practices incorporated into this Streetscape Master Plan can be found on the following pages:

**Road Diet (Page 4-3)** Removal of travel lane, curb extensions, and extension of sidewalk promote and enhance walking and transit use

**Street Lighting (Pages 4-9; 5-13)** Utilization of existing bases and incorporation of LED luminaires

**Vegetated stormwater curb extensions (Pages 5-3 through 5-4)** Storm water management to clean storm water before returning to the storm drain system

**Restoration of Historic Fabric (Pages 2-2 through 2-3)**

**Reduction of Heat Island Effect (Page 5-2)** Incorporation of street trees to create shade

**Native and Drought Tolerant Planting (Page 5-3)** Low-water using plants incorporated into vegetated stormwater curb extensions.

**Sustainably Manufactured and Sourced Materials (Page 5-9)** Benches and chairs specified are comprised of steel from domestic furnace mills, with 98% of the steel's composition obtained from recycled scrap metal.

## Paseos

Specific attention was paid in this Plan to pedestrian connections to and from Broadway. In order to prioritize the pedestrian on Broadway, destinations must be safe and easy to reach, transportation must be easy and understandable, and the journey must be pleasant, beautiful, informative, and interesting. A series of connections has been considered, and a plan can be found in the appendix to this document.

## Thresholds

Whether through subtle variations in paving materials, or through signage and



**Figure 3-1B: Visualization of Preferred Configuration – 3 lanes: 1SB, 2NB**

Looking South Toward a Midblock Crossing

iconic visual elements, creating a sense of arrival on Broadway will be critical to strengthening the identity of this historic corridor as well as for effective wayfinding for pedestrians and transit users.

## 4.0 STREETSCAPE PLAN

**3 LANES** 1 Southbound, 2 Northbound

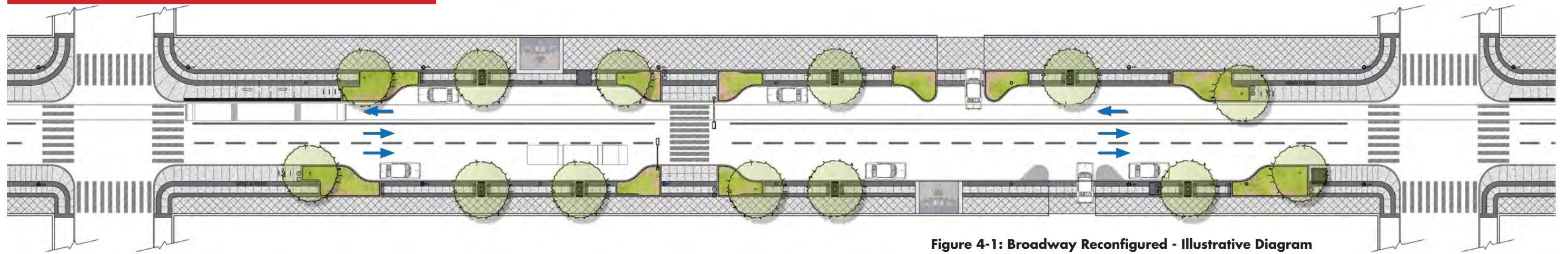

**Figure 4-1: Broadway Reconfigured - Illustrative Diagram**

### THE STREET DESIGN – BROADWAY RECONFIGURED

As described in Chapter 2, Existing Conditions, Broadway is currently carrying bus and vehicular traffic in a total of five travel lanes, three northbound and two southbound. Loading/parking zones on both sides of the street are dominated by bus stops that occur without a regular pattern nearside, farside and at the midblock of intersections. Broadway is a chaotic, noisy, and unpredictable environment for pedestrians, with traffic moving at brisk speeds immediately next to the curb.

To prioritize the pedestrian and transit user over the private automobile, enhance transit accessibility, provide an appropriate context for the restoration of historic streetcar service, and create a more hospitable street experience overall, this Streetscape Master Plan calls for the reconfiguration of Broadway (see Figure 4-1).

Several configuration alternatives were explored, each with their own merits and drawbacks. (See Chapter 2 for a description of the project process, and the Appendix for a more detailed look at the design alternatives.) With a thorough evaluation of technical and urban design considerations, community feedback, City staff input, stakeholder input, and traffic analysis, a preferred alternative for the design and reconfiguration of Broadway was vetted and selected by the stakeholders involved.

Several specific design goals emerged throughout the project process, as stakeholders provided their input on their vision for the streetscape and technical aspects of the street were explored by the project team:

- To the extent possible, develop streetscape improvements and add amenities in the public realm on *both* the east and west sides of the street.
- Provide dedicated parking/loading zones on the street to serve businesses and theatres with little or constrained alley access in this historic district.
- Facilitate universally accessible pedestrian access to transit service on the curb edge of the street.
- Reduce potential streetcar construction costs by laying streetcar track outside the

utility zone currently next to the curb in the street bed.

Overall, the physical changes of the street design serve to create a transit-focused street that gives primacy to the pedestrian and supports the revitalization of a renewed historic theatre district. A reconfigured Broadway achieves the following:

- Widened sidewalk on west side of street provides for a generous public realm and the addition of street trees and coordinated streetscape features and amenities.
- Curb extensions create parking/loading zones as well as shorter crossing distances for pedestrians for both east and west sides of the street, as well as areas for planting and trees.
- Sidewalk extension on the west side of the street pushes potential streetcar as far away as possible from utility zone, avoiding costly utility relocation.

Traffic studies completed as this Plan was developed show that all study intersections operate at an acceptable level of service in existing and future conditions. However, the Broadway and 3rd Street intersection is forecast to experience a significant traffic impact during the AM and PM peak hours. This impact does not result in an unacceptable level of service at the intersection, but does result in a volume to capacity ratio (V/C ratio) that exceeds LADOT standards. Still, traffic impacts from this reconfiguration are mitigable. Initial considerations and recommendations to address impacts are as follows, and will be further detailed in the environmental analysis to accompany this Plan:

- Traffic impacts at the intersection of Broadway and 3rd Street could be mitigated with a 15% percent reduction in traffic volumes on Broadway, achieved in part by the provision of improvements proposed in this Plan.
- Implement a satellite mobility hub on Broadway within one block of the 3rd Street intersection.
- Implement pedestrian wayfinding signage on Broadway, 5th Street, and 1st Street directing pedestrians to and from the Project corridor and the Metro Red Line and

Purple Line Pershing Square and Civic Center stations.

- Work with Metro to provide additional information regarding bus transit service routes, service frequency, and transfer information at all bus stops and bus shelters implemented in the corridor.

### HOW TO USE THIS CHAPTER

The physical reconfiguration of Broadway drives the future application of the materials palette, or “kit of parts,” and design and location criteria contained in this chapter, and in Chapter 5, Materials Palette & Location Criteria. Detailed diagrams are provided for specific physical features relating to the reconfiguration of Broadway, including transit stops for potential streetcar and bus service, non-transit curb extensions at intersections, curb extensions at midblock crossings, treatment and design of driveways, and the strategy for the placement of streetlights.

These diagrams also contain a general strategy for locating the streetscape elements detailed further in Chapter 5, Materials Palette and Location Criteria. Keys for each diagram cross-reference specific page numbers in Chapter 5. For instance, each streetscape element found at a transit stop is numbered on the diagram showing a typical stop, and listed with corresponding Chapter 5 page numbers in the diagram’s key.

In addition, at the beginning of Chapter 5, a discussion on the original design inspiration for this palette, and general design strategies guiding the palette and its criteria, provides an understanding of the logic of the palette as a whole. Thus, Chapters 4 and 5 are to be used together as a tool for the future application of the streetscape elements called for in this Plan, and should be cross-referenced.

**PLAN VIEW**

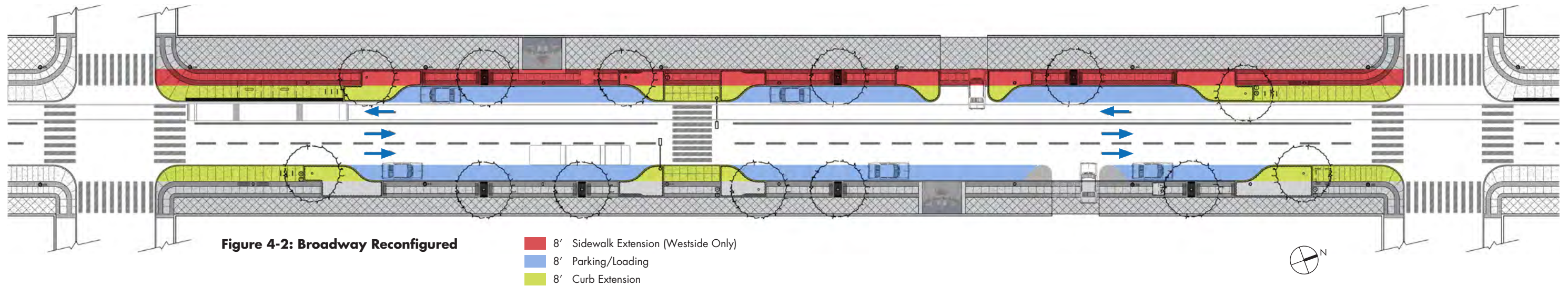

**Figure 4-2: Broadway Reconfigured**

- 8' Sidewalk Extension (Westside Only)
- 8' Parking/Loading
- 8' Curb Extension

**EXISTING STREET CONFIGURATION & USE**

As shown in Figure 4-3: Existing Configuration, Broadway currently conveys five lanes of traffic in a north-south direction through the project area of this Streetscape Master Plan, and is a major arterial in Downtown Los Angeles with a 56' curb-to-curb width. Three lanes run northbound, and two run southbound, with a third southbound "ghost lane" serving as an unofficial bus turnout zone. There are no bicycle lanes or facilities on Broadway and it is not included in the City's Bicycle Master Plan. Traffic analysis conducted as part of this Streetscape Master Plan process reveals that a majority of traffic at peak hours flows northbound along Broadway, towards Downtown's Civic Center. Sidewalks average 17' on each side of Broadway the length of the project area.

Curbside lane space not reserved for bus stops is limited along Broadway, with buses stopping at intersections, midblocks and in between depending on constraints at each block. There is no stopping, parking or loading permitted on either side of Broadway during peak hours (7:00-9:00 AM and 3:00-7:00 PM Mon-Fri; 7:00 AM - 7:00 PM Saturday). There is no parking nightly, 2:00-5:00 AM. Loading is the primary use of curb zones during business hours. Commercial vehicles are allowed to stop for 20 minute intervals and passenger vehicles are allowed to stop for 3 minute intervals from 9:00 AM - 3:00 PM, Mon-Fri. Cars are allowed to park on Broadway in these zones from 7:00 PM - 2:00 AM.

Presently, 62% of the total Right of Way of Broadway is dedicated to vehicular traffic, with 38% dedicated to pedestrians. The street reconfiguration described herein changes that distribution of space to 53% for vehicles, and 47% for pedestrians.

**SECTION VIEW**

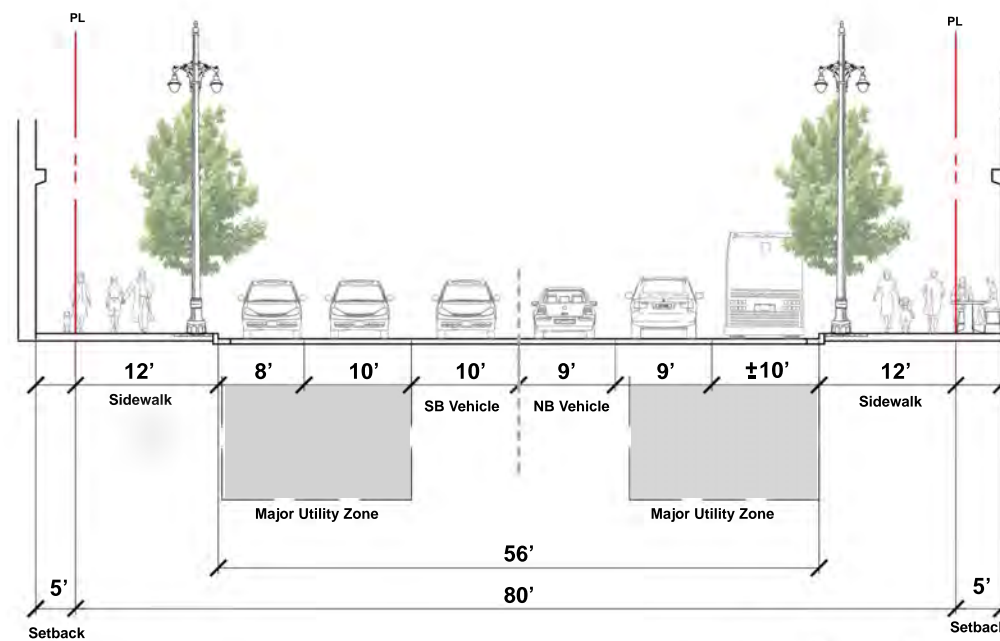

**Figure 4-3: Existing Configuration (looking North)**

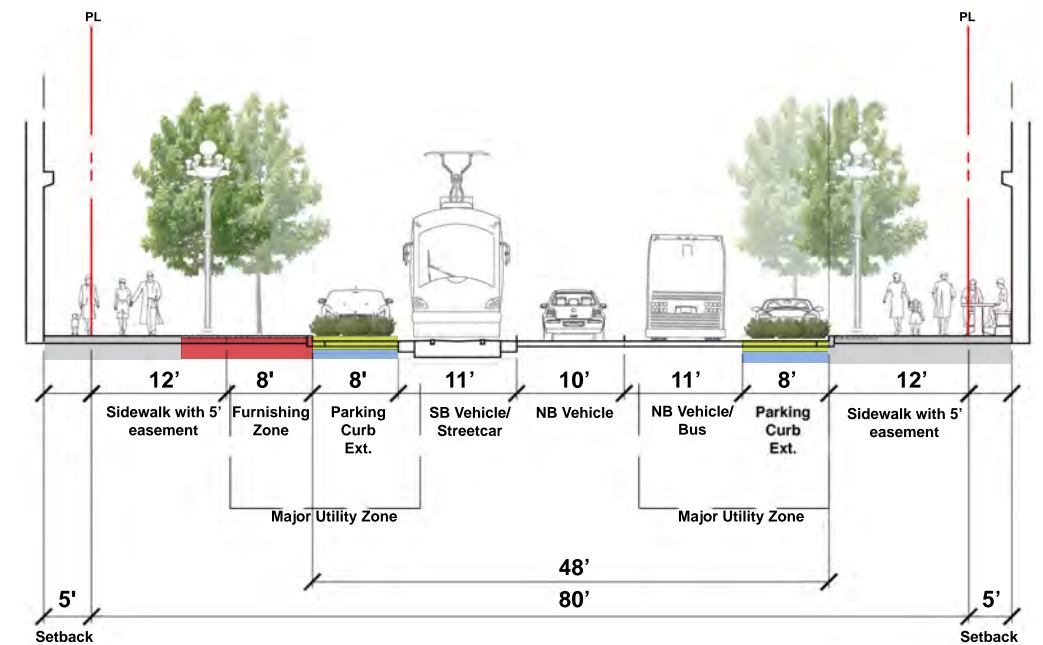

**Figure 4-4: Proposed Configuration (looking North)**

## RECONFIGURATION: THREE MAJOR FEATURES

The major features of Broadway's reconfiguration, three travel lanes, sidewalk extension, curb extensions, and parking/loading zones are discussed in detail below. These changes constitute the overall urban redesign of Broadway called for in this Streetscape Master Plan.

### Three Travel Lanes

Broadway will be reconfigured to contain three travel lanes total, one 11' lane southbound and two 10' lanes northbound. The two northbound lanes will carry vehicular and transit traffic; the one southbound lane will carry vehicular and transit traffic. **Full or partial implementation of this lane configuration on blocks adjacent to the Streetscape Plan area will be at the discretion of LADOT.** There are no "dedicated" lanes for transit service - Broadway will become a true multi- and inter-modal street, with lanes shared by the various modes. (See Figures 4-2 and 4-4.)

Plans for the restoration of historic streetcar service show a streetcar that would only run southbound on Broadway, which would be one leg of a couplet-style streetcar route that would connect neighborhoods within Downtown Los Angeles. As the route for the restored streetcar is still in planning at this time, it is not known which street would serve as the northbound leg of the couplet, but Hill Street is a likely candidate.

Preliminary traffic analysis indicates that the reconfiguration of Broadway to three travel lanes will have no significant impact on the level of service, except on Broadway and Third Street, which can be mitigated through signal timing and other measures. See the Appendix for more information on the preliminary traffic analysis conducted as part of this Master Plan process.

### Sidewalk Extension on West Side

The sidewalk on the west side of Broadway will be extended by 8 feet. (The east side of the street will not receive an extension.) Extensions of 4' on each side of Broadway were considered in the project, but an 8' extension on one side of the street offered many benefits that smaller extensions on both sides would not. This extra 8' of sidewalk will provide a generous pedestrian realm on this side of the street, affording ample space for not only street furnishings but also space for transit stops, which are accompanied by transit shelters, signage, and other amenities. (See Figures 4-4 through 4-8.)

In addition, pushing the curb 8' inward allows for the fixed track bed infrastructure for the planned restoration of historic streetcar service to conflict as little as possible with an existing utility zone under the street, avoiding costly utility relocation and reconstruction if the service is implemented. Together with the 8' curb extensions described in detail below, the 8' sidewalk extension creates a flexible space with high visibility to

enhance transit accessibility and user comfort and experience.

This additional 8' on the west side of the street also allows for more flexibility and opportunity for tree planting, bringing the sidewalk away from the many basements that, in many cases, extend under the original 17' sidewalk out to the existing curb.

### Curb Extensions, Parking/Loading Zones

8' curb extensions will be added at intersections and mid-block locations on both the west and east sides of Broadway, where feasible. (See Figure 4-2 and Figures 4-4 through 4-8.) These curb extensions will shorten pedestrian crossing distances, calm traffic, and will create protected parking and loading zones on both sides of the street. Special consideration of the placement of the curb extensions and parking/loading zones will be necessary on blocks where historic theatres are located on the west side of Broadway, in order to accommodate valet/passenger drop-off needs for special events.

Curb extensions will provide the opportunity to create a unique sustainable design feature on Broadway, bioinfiltration planters. These planters can also accommodate street trees. As rain and other waste water moves along the curb it will flow through the infiltration planters before it eventually reaches storm drain inlets. Plant materials will cleanse the water as it moves through, improving overall water quality and sustaining the drought-tolerant plant materials contained within.

The opportunity to incorporate street trees in the curb extensions will be a significant benefit to the east side of the street, which will retain its existing curb line. Because of constraints such as the basements that extend under the sidewalks in many locations, as well as utility zones that run along the existing curb, tree planting opportunities are few and far between in the existing condition. With the addition of curb extensions, intersections and midblock crossings will accommodate tree plantings where feasible and not in conflict with historic theatre or significant building facades. These locations are also slated for concentrations of pedestrian amenities and street furnishings, as well as seating alcoves, which will benefit from shading by trees.

Also, curb extensions at intersections accommodate transit stops. Bus and the proposed restoration of historic streetcar service would stop at the nearside of each intersection on the west, or southbound, side of Broadway. Transit shelters and other amenities and furnishings will be provided in these curb extensions at the nearside of intersections. In an ideal scenario, bus service would stop at curb extensions on the farside of intersections, on both east and west sides of Broadway. However, each intersection will need a closer look, and suggested options are detailed in Figure 4-6.

Curb extensions at midblock crossings will not accommodate transit stops and be smaller in size. They will contain furnishings and amenities, such as seating, vending and information kiosks.

All curb extensions, regardless of position, will shorten pedestrian crossing distances, protect parking/loading zones, provide opportunities for planting, trees and storm water management, and offer space for coordinated street furnishings, seating areas and other amenities.

Criteria for locating and the physical design of curb extensions are detailed further in Figures 4-5 through 4-10 and Chapter 5.

## TRANSIT STOPS Bus/Streetcar and Bus

Transit stops will be provided on Broadway within curb extensions at intersections. This will ease navigation of the various transit modes on the street, and facilitate transfers to connecting service, and wayfinding to nearby destinations.

Figure 4-5 illustrates the dimensions of transit stop curb extensions, as well as streetscape elements to be located at each. For a detailed catalog of streetscape elements found at transit stops, refer to Chapter 5 using the key below.

### Transit Stops Serving Both Metro Bus and Potential Restoration of Historic Streetcar Service

The potential restoration of historic streetcar service would be accommodated along with bus service on the west side of Broadway, southbound through the corridor. Transit stops accommodating both bus and the potential restoration of historic streetcar service would be located at the nearside of each intersection found within the project area, Broadway from 2nd Street to Olympic Boulevard. These transit stops will contain shelters and other furnishings and amenities, as well as station marker signage. (See Chapter 5 for a conceptual rendering of the design of transit stop shelters.)

Transit stop shelters will be modular in design, so that two or more can be located at each station based on expected levels of use or at intersections known to have high volumes of pedestrian activity.

Shelters will also allow for high levels of visibility, with an open-air design. No walls will obstruct visibility or pedestrian circulation within the station area, and transit rider information, wayfinding signage, and historical exhibits will be incorporated into the base of the structure(s).

Bike racks will be located immediately adjacent to shelters, so as to accommodate and make convenient intermodal transfers.

To create additional public-realm opportunities for outdoor “living rooms” and enliven the streetscape, this Plan calls for the integration of seating alcoves at bioinfiltration planters located on transit-serving curb extensions at intersections, as shown in Figure 4-5. Seating alcoves are designed to be notches cut out of vegetated stormwater curb extension area, so that the alcoves are protected and softened on two sides by planting, and are covered with the shade of a tree planted within the vegetated stormwater curb extension. A bollard with integrated lighting positioned between two chair-sized benches will provide an informal table, and these elements will be positioned facing inward to provide for a conversational configuration. For a detailed catalog of streetscape elements found at seating alcoves, refer to Chapter 5 using the key below.

#### KEY MAP

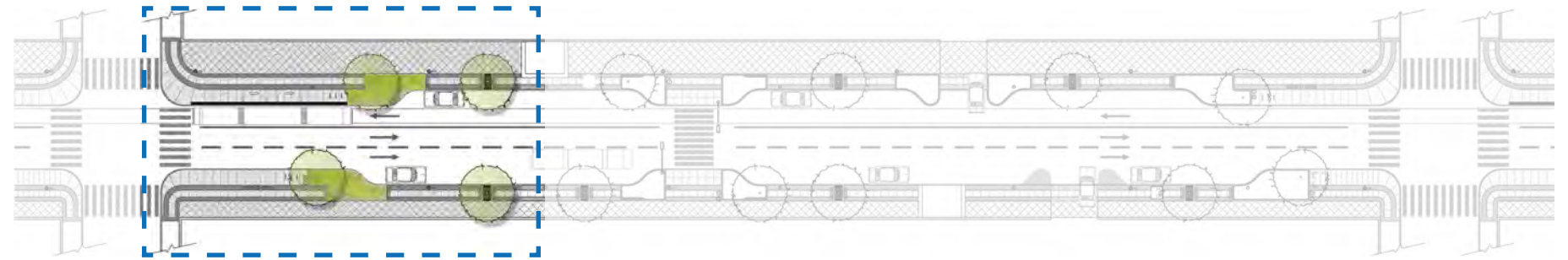

#### TYPICAL TRANSIT STOPS

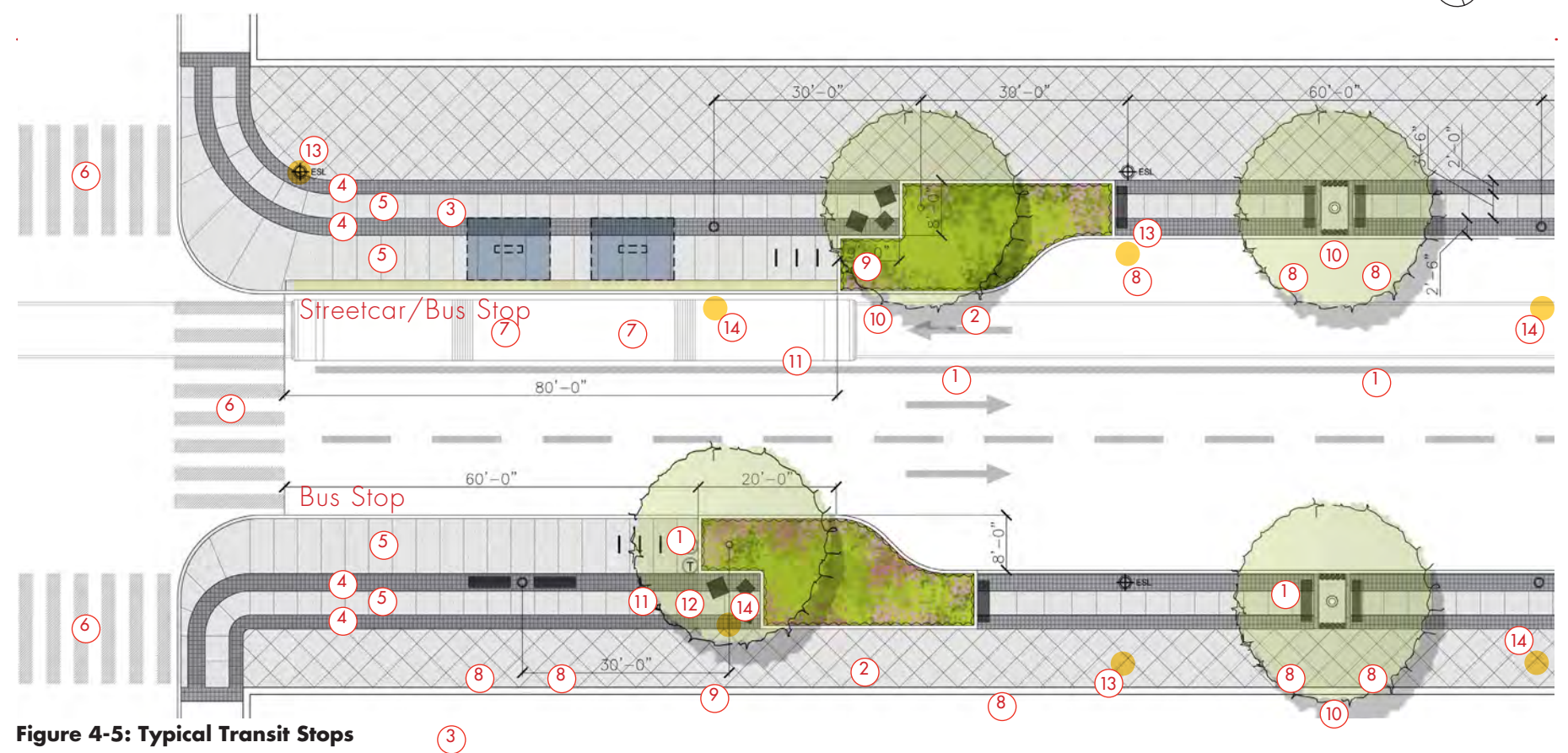

Figure 4-5: Typical Transit Stops

#### KEY (REFER TO CHAPTER 5)

- |   |   |                             |                                   |
|---|---|-----------------------------|-----------------------------------|
| 1. Street Trees (pg 5-2)                              | 4. Paving Material 2 - Granite Cobble (pg 5-2)                | 7. Transit Shelter (pg 5-8) | 11. Bike Rack (pg 5-11)           |
| 2. Vegetated stormwater curb extension (pg 5-3)       | 5. Paving Material 4 - Scored Concrete at 45° (pg 5-5)        | 8. Bench - Full (pg 5-9)    | 12. Trash Receptacle (pg 5-11)    |
| 3. Paving Material 1 - Scored Concrete Field (pg 5-5) | 6. Paving Material 5 - Painted Continental Crosswalk (pg 5-7) | 9. Seating Alcove (pg 5-9)  | 13. Lighting - Existing (pg 5-13) |
|   |   | 10. Tree Grate (pg 5-10)    | 14. Lighting - Proposed (pg 5-13) |

## Metro Local and Rapid Bus

Metro Bus service will be accommodated on both east and west sides of Broadway. On the east side of Broadway, it is preferred that buses stop on the farside of intersections at curb extensions, however, nearside curb extensions can be extended in length to accommodate a bus stop if needed. On the west side of Broadway, where buses, the proposed restoration of historic streetcar service, and vehicles share one southbound lane, it is preferred that buses stop at farside curb extensions. *However, buses and streetcars can share a nearside stop with a curb extension that is extended in length.* (See Figure 4-5 for a diagram of and criteria for the design of bus and streetcar/bus curb extensions.) Buses also have the option of stopping at a bus turnout nearside of the intersection before the streetcar curb extension. (See Figure 4-6 for a diagram of and criteria for bus options.)

This Plan investigates several options for accommodating bus service, each of which can be applied as necessitated by constraints on the street, and the needs of Metro bus service, to facilitate the efficient flow of traffic on Broadway. The Preferred Configuration, illustrated in Figures 4-1 and 4-2, shows the ideal scenario for bus accommodation. On both the east and west sides of the street, bus stops are located at the farside of intersections. As depicted in the “bus option” diagrams, bus service could also be accommodated at the nearside of the intersection on the east side of the street, or nearside in a loading/waiting zone on the west side of the street before a streetcar curb extension. Thirdly, on the west side of the street, buses could share a curb extension stop with the streetcar, as long as the curb extension itself is sufficiently lengthened.

Bus stops will contain similar streetscape furnishings as bus/streetcar stops (as discussed above), such as a seating alcove and bike racks. However, in place of a custom shelter, benches will be provided. For a detailed catalog of streetscape elements found at seating alcoves, refer to Chapter 5. Bus route signage and trash collection will be provided per usual by Metro.

### BUS OPTIONS to reduce traffic back-up

#### 1. Streetcar & Bus Share Nearside Stop & Additional Far Side Bus Stop

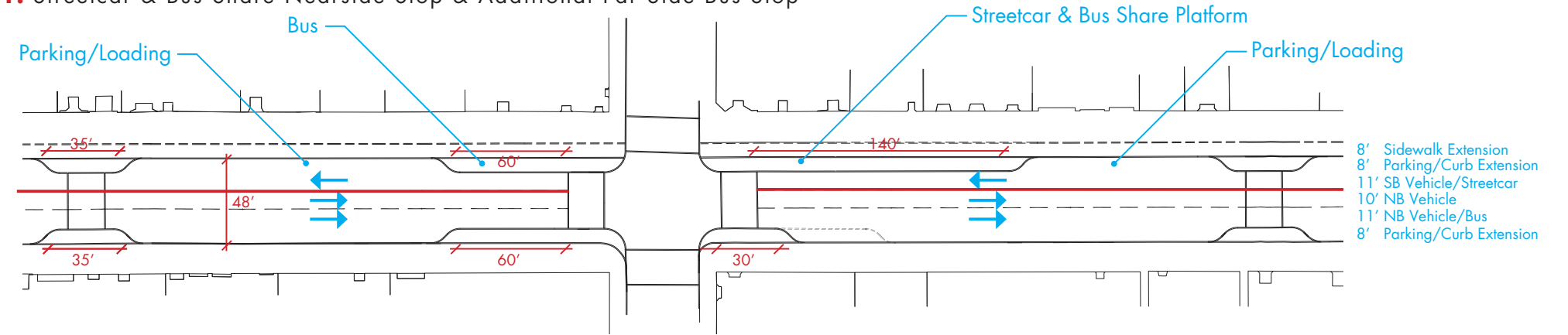

#### 2. Farside Bus Stop + Bus Loading/Waiting Zone Nearside, Prior to Streetcar Stop

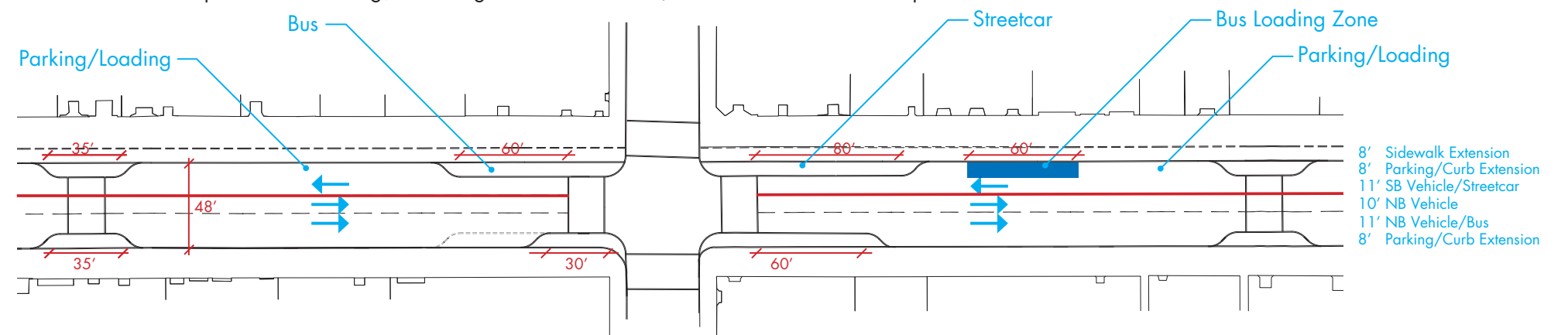

Figure 4-6: Bus Options



## CURB EXTENSION AT INTERSECTION Non-Transit

Curb extensions at intersections that do not serve transit will typically be shorter in length, as shown in Figure 4-7. Depending on bus accommodation, non-transit curb extensions contribute to a safer, more pleasant pedestrian experience by shortening crossing distance and offering sufficient space for waiting away from the edge of the curb for crossing. This 8' of extra width afforded by the curb extension will also accommodate space for vendor kiosks and allow for vegetated stormwater curb extensions for storm water management.

Figure 4-7 illustrates both appropriate dimensioning for the design of non-transit curb extensions at intersections as well as streetscape elements to be located at each one. For a detailed catalog of streetscape elements found at non-transit curb extensions at intersections, refer to Chapter 5 using the key below.

### KEY (REFER TO CHAPTER 5)

1. Street Trees (pg 5-2)
2. Vegetated stormwater curb extension (pg 5-3)
3. Paving Material 1 - Scored Concrete Field (pg 5-5)
4. Paving Material 2 - Granite Cobble (pg 5-5)
5. Paving Material 4 - Scored Concrete at 45° (pg 5-5)
6. Paving Material 5 - Painted Continental Crosswalk (pg 5-7)
7. Bench - Full (pg 5-9)
8. Tree Grate (pg 5-10)
9. Bike Rack (pg 5-11)
10. Trash Receptacle (pg 5-11)
11. Kiosk (pg 5-12)
12. Lighting - Existing (pg 5-13)
13. Lighting - Proposed (pg 5-13)

### KEY MAP

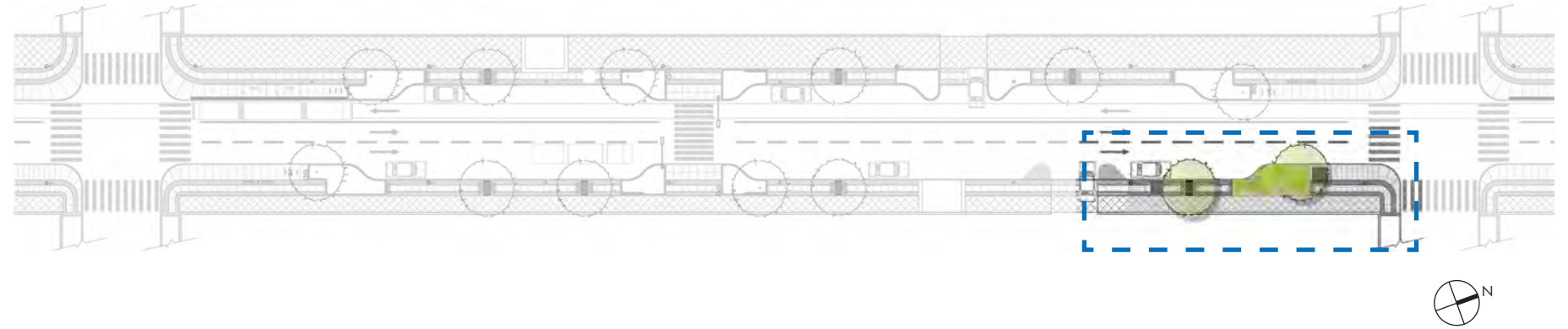

### TYPICAL CURB EXTENSION AT INTERSECTION (NON-TRANSIT)

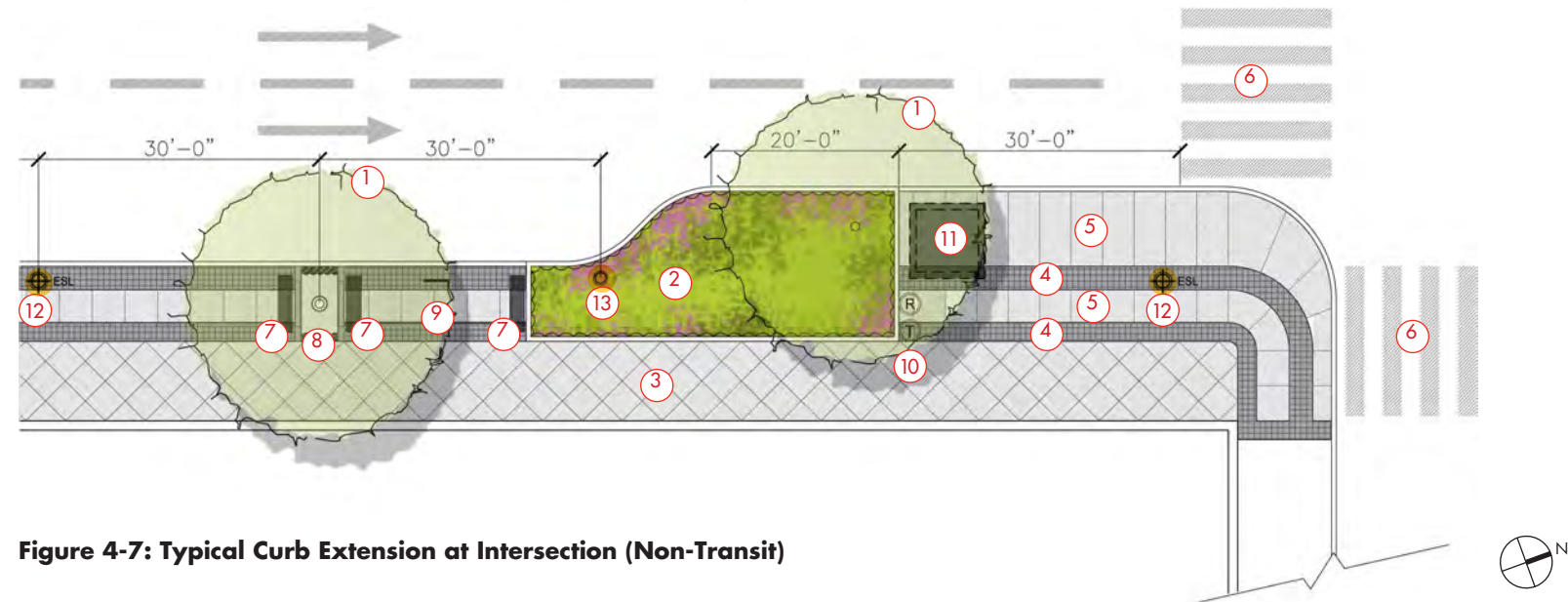

Figure 4-7: Typical Curb Extension at Intersection (Non-Transit)

## MIDBLOCK CROSSINGS

Midblock crossings will incorporate 8' curb extensions on both east and west sides of Broadway, shortening pedestrian crossing distance and providing refuge from traffic while waiting for crossing. Vegetated stormwater curb extensions located at either side of midblock crossings, as shown in Figure 4-8, will offer opportunities for tree planting as well as stormwater management. Trash receptacles will also be located at midblock curb extensions.

Figure 4-8 illustrates both appropriate dimensioning for the design of midblock crossings as well as streetscape elements to be located at each midblock crossing. For a detailed catalog of streetscape elements found at midblock crossings, refer to Chapter 5 using the key below.

### KEY (REFER TO CHAPTER 5)

1. Street Trees (pg 5-2)
2. Vegetated stormwater curb extension (pg 5-3)
3. Paving Material 1 - Scored Concrete Field (pg 5-5)
4. Paving Material 2 - Granite Cobble (pg 5-5)
5. Paving Material 4 - Scored Concrete at 45° (pg 5-5)
6. Paving Material 5 - Painted Continental Crosswalk (pg 5-7)
7. Bench - Full (pg 5-9)
8. Seat Wall (pg 5-10)
9. Tree Grate (pg 5-10)
10. Bike Rack (pg 5-11)
11. Trash Receptacle (pg 5-11)
12. Kiosk (pg 5-12)
13. Lighting - Existing (pg 5-13)
14. Lighting - Proposed (pg 5-13)

### KEY MAP

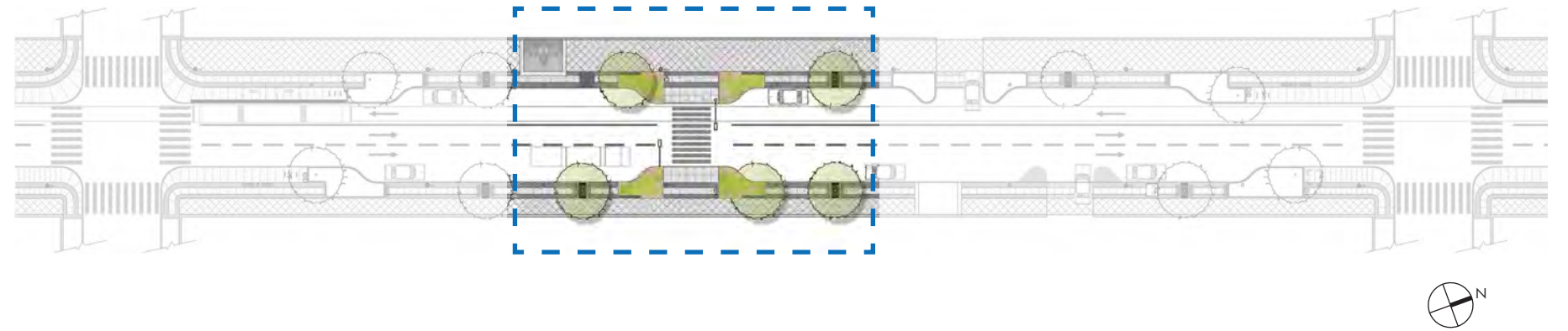

### TYPICAL MIDBLOCK

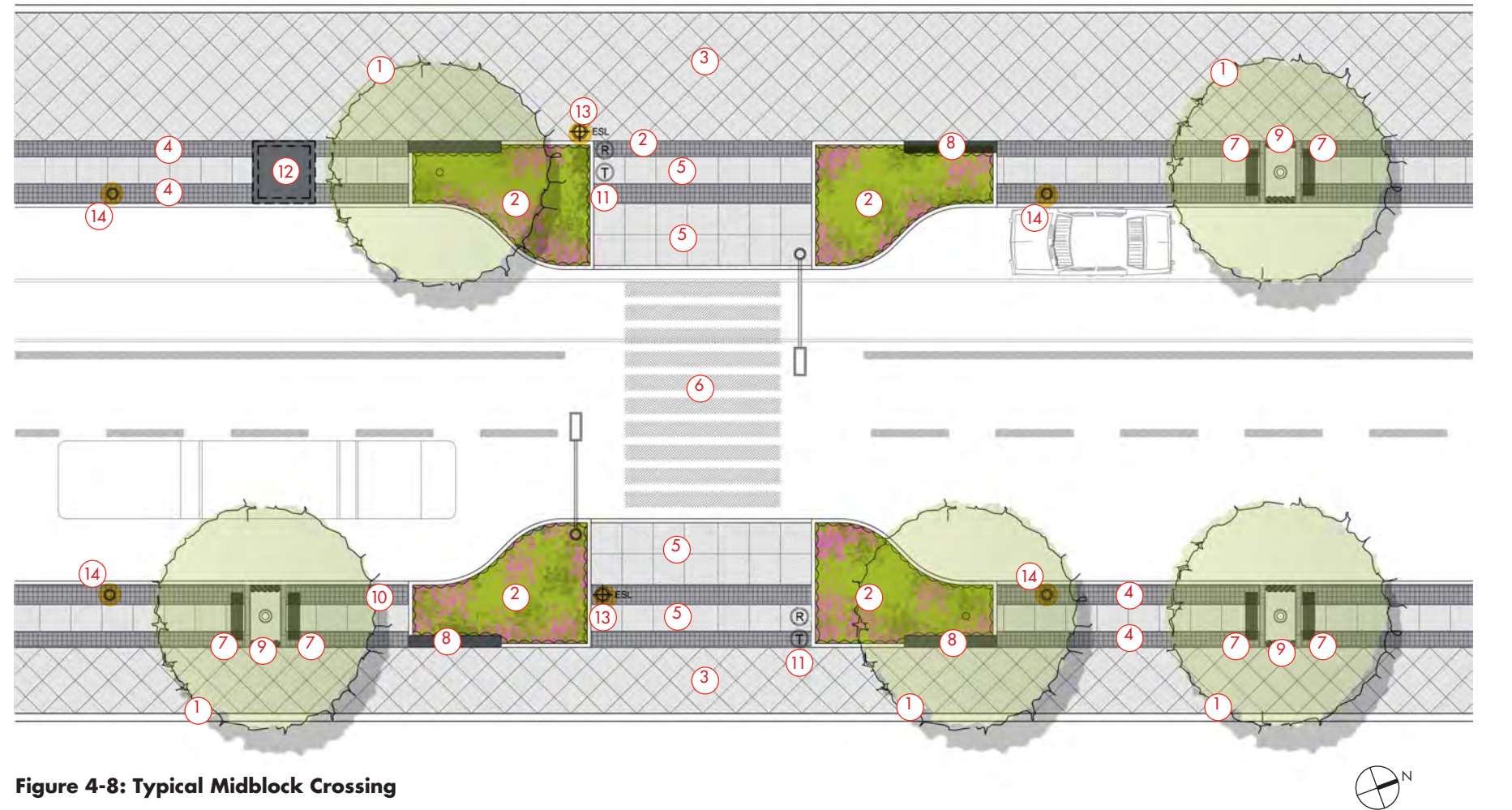

Figure 4-8: Typical Midblock Crossing

## DRIVEWAYS

Figure 4-9 illustrates appropriate dimensioning for the design of vegetated stormwater curb extensions at driveways, and Figure 4-10 illustrates dimensioning for the design of striped bulb-outs at driveway conditions. However, curb cuts should be minimized on Broadway in the future, and driveway access relocated to side streets and alleys where feasible.

As such, this Plan outlines two driveway treatments. Permanent driveways that provide primary access to a building or site, and that can not be relocated, will be flanked by vegetated stormwater curb extensions, as shown in Figure 4-9.

Driveways that are currently functioning, but that can be phased out in the future and relocated to side streets or alleys, will be flanked by painted and striped bulb-outs, as shown in Figure 4-10.

Both treatments protect parked vehicles or vehicles located in loading zones from the ingress and egress of vehicles at driveways, and require that drivers slowly exit driveways to minimize conflicts with pedestrians and oncoming traffic.

### KEY (REFER TO CHAPTER 5)

1. Street Trees (pg 5-2)
2. Vegetated stormwater curb extension (pg 5-3)
3. Paving Material 1 - Scored Concrete Field (pg 5-5)
4. Paving Material 2 - Granite Cobble (pg 5-5)
5. Paving Material 4 - Scored Concrete at 45° (pg 5-5)
6. Paving Material 6 - Painted Driveway Bulb Out (pg 5-7)
7. Bench - Full (pg 5-9)
8. Tree Grate (pg 5-10)

### KEY MAP

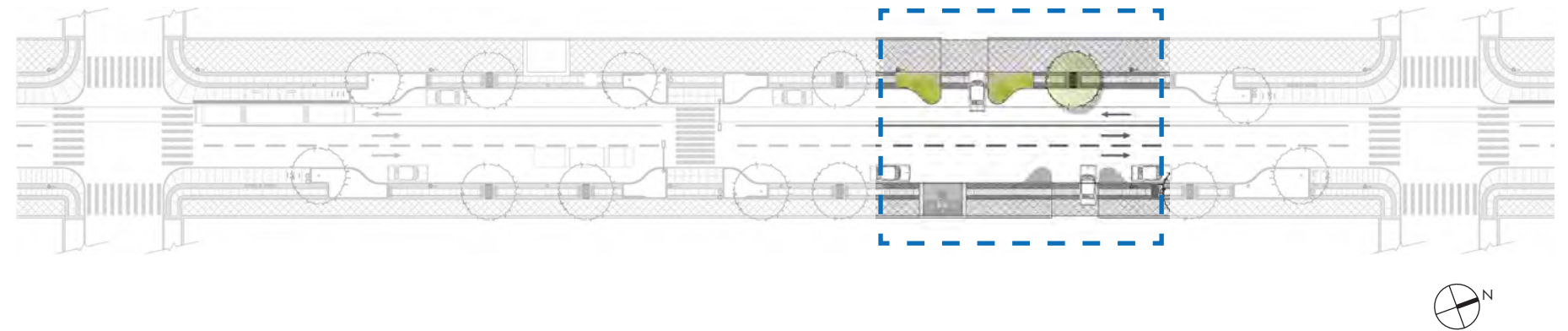

### TYPICAL DRIVEWAYS

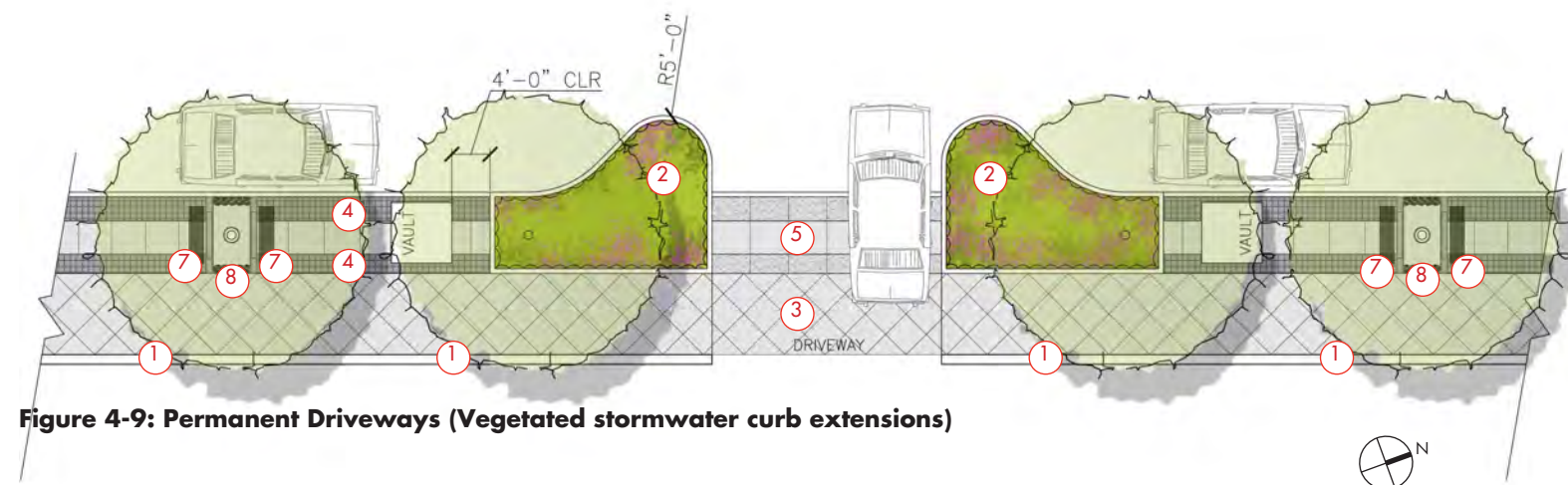

Figure 4-9: Permanent Driveways (Vegetated stormwater curb extensions)

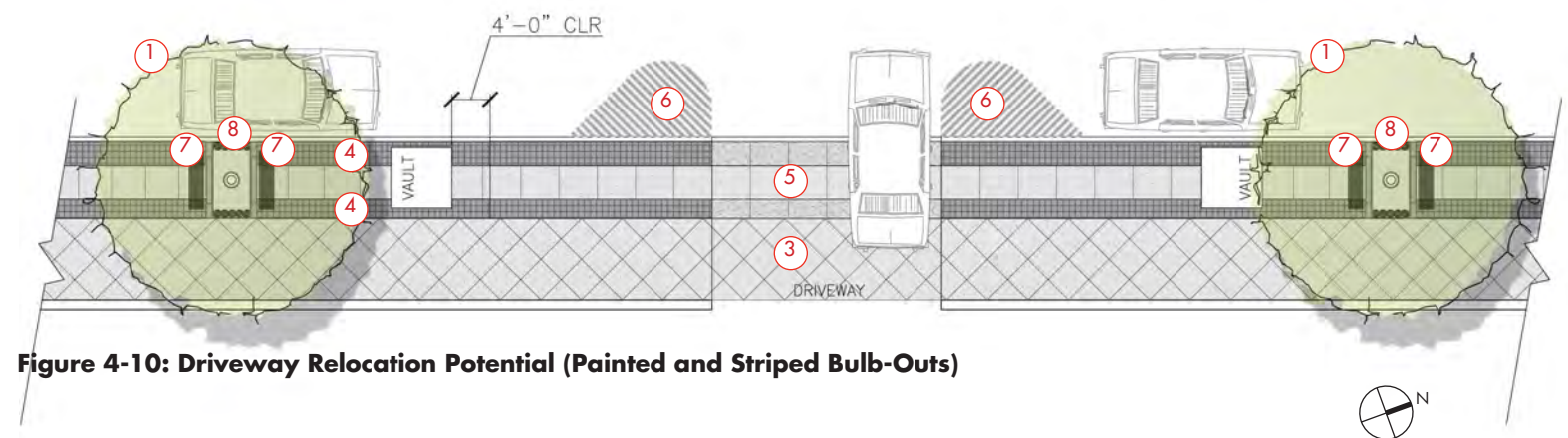

Figure 4-10: Driveway Relocation Potential (Painted and Striped Bulb-Outs)

## STREET LIGHTING

The street lighting strategy for Broadway is a major component of this Streetscape Master Plan and serves to preserve, restore, reintroduce and feature this piece of the historic fabric of Broadway. This Plan calls for the retention and restoration of the historic streetlight bases that still exist along the entire project area. See Chapter 5, Materials Palette & Location Criteria, for a more detailed look at the streetlight strategy.

This Plan calls for infilling streetlights at approximately 120' on center, one infill light between each existing light. (60' spacing between each street light on average.) Existing streetlight bases will be maintained and utilized in place. Infill lights will consist of re-creations of the Llewellyn 7-light poles, Broadway's first street lighting system. See Figure 4-11 for a graphic representation of the street lighting strategy.

The closer spacing (approx. 60' on center) will allow for a higher quality and more consistent lighting of both the roadway and the pedestrian realm. In addition, the using LED technology to illuminate Broadway will further create a more even, consistent distribution of light, while at the same time consume less energy, as shown in Figure 4-12.

On the east side of Broadway, existing streetlights and new infill streetlights will be located along the existing curb, as there is no sidewalk extension proposed for this side of the street. The west side of the street, however, will feature a staggered streetlight placement, due to the 8' sidewalk extension. Here existing streetlights will remain in place along the existing curb line; proposed infill streetlights will be located at the new curb, 8' towards the centerline from where the existing streetlights reside, creating a staggered effect, offering a more complete illumination pattern for this widened pedestrian realm.

### KEY (REFER TO CHAPTER 5)

- Lighting - Existing (pg 5-13)
- Lighting - Proposed (pg 5-13)
- >2 fc (high intensity of light)
- 1-2 fc (moderate intensity of light)
- <1 fc (low intensity of light)

### PLAN VIEW

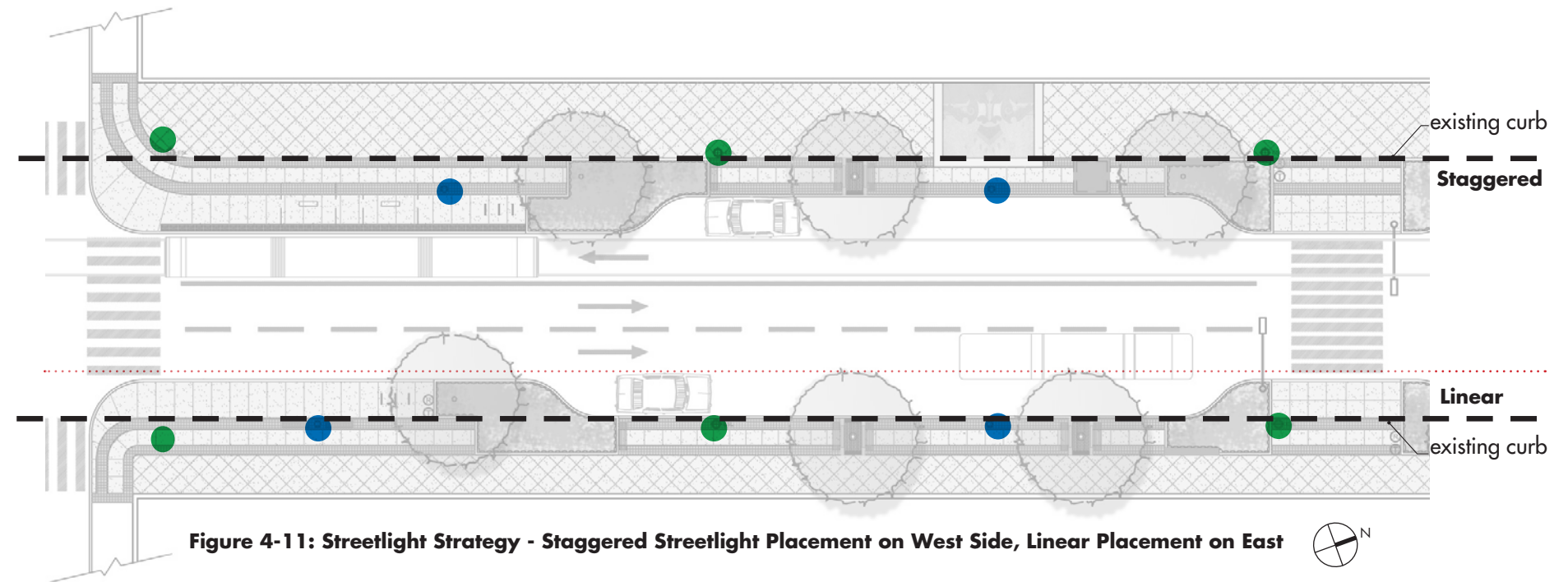
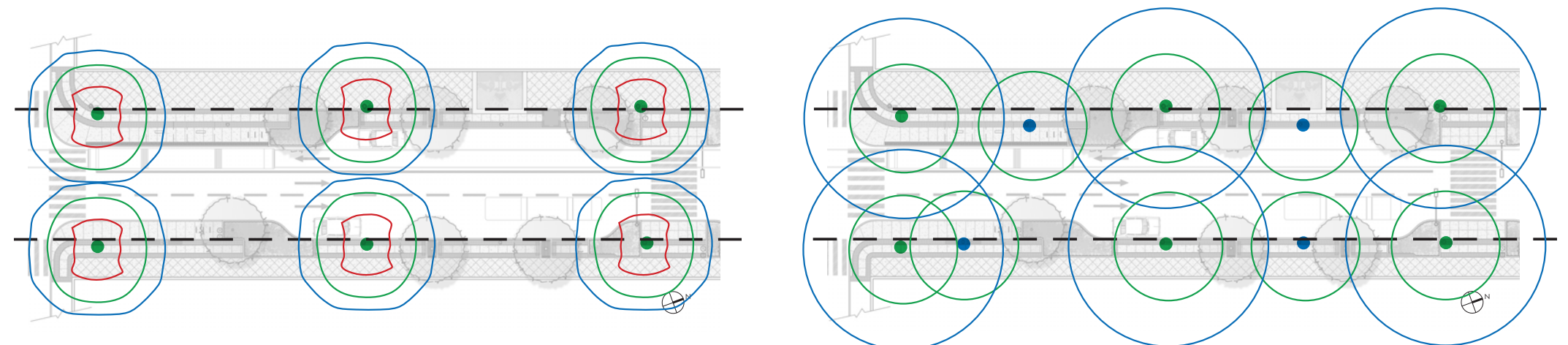

Figure 4-11: Streetlight Strategy - Staggered Streetlight Placement on West Side, Linear Placement on East



#### Existing High Pressure Sodium with dual 200 watt fixtures

- Hotspots
- Uneven distribution
- Total energy used = 554 watts

#### Proposed Energy Efficient LED fixtures

- More even, uniform distribution of light
- Enhanced visibility, safety, and pedestrian experience
- Total energy used = 350 watts for dual system roadway/pedestrian lighting

Figure 4-12: Streetlight Strategy - Existing High Pressure Sodium vs. Proposed Energy Efficient LED

\* Provided by City of Los Angeles, Bureau of Street Lighting

THIS PAGE LEFT INTENTIONALLY BLANK

## 5.0 MATERIALS PALETTE & LOCATION CRITERIA

### HISTORIC CHARACTER/DESIGN INSPIRATION

A guiding principle throughout this project has been to reveal and showcase the existing historic fabric of Broadway. The intention of this palette is to provide amenity without diverting attention away from the historic elements of the street – the theatres, and their associated marquees, terrazzo paving and glass blocks. Through material and planting choices this palette will create an elegant and understated streetscape that frames the historic environment in which it sits.

### MATERIALS PALETTE ELEMENTS

#### Planting

A single species of tree will be used throughout the corridor. This tree will be visually permeable and deciduous in order to provide shade while still maintaining views. Trees will not be planted in front of the historic theatres. Understory vegetation will be similarly simple - mass planted swathes of low growing species that will provide year round color.

#### Furnishings

The furniture palette consists of transit shelters, benches, bollards, seat walls, tree grates, bike racks, trash receptacles and kiosks. Through careful material and color choices, furnishings shall be subtly integrated into the streetscape. All furnishings will be black and shall be located only as necessary to provide amenity without adding clutter to the street environment.

#### Lighting

The existing street lights on Broadway replaced the historic street lights, when they were installed in the 1940s, to more adequately address the needs of automobiles. The historic street lights were more ornate and shorter than the lights that exist today. The only remaining elements of the historic lights are the bases. This Plan proposes preserving existing street light poles including the 'Spanish Renaissance' bases, and adding a pedestrian-scale lighting system with replicas of the original street lighting poles, thus remaining consistent with the original pedestrian-oriented vision for Broadway.

#### Identity, Wayfinding, & Information

Identity, wayfinding and information is to be provided via a family of signs designed to replace the varied and diverse designs currently seen on the street. This signage palette is designed to create sense of place and identity

through the use of a simple color palette (black, white & silver) and shapes that interpret classic theatre signage in modern ways. Art deco patterns add to the historic character of the street. The materials reflect high levels of practicality and durability. Typography selection emphasizes readability and flexibility.

#### Unified Power Source

In consultation with utility providers and private property owners, future implementation of this Streetscape Master Plan may consider the consolidation of electrical power generation stations in underground vaults that serve multiple buildings. If feasible, this could minimize space needed for power transformers and sub-stations which, when required in order to provide ample and appropriate power to meet a building's needs, are difficult to accommodate in historic buildings, and expensive to install, and thus present a disincentive to reactivation of underutilized buildings along Broadway.

### HOW TO USE THIS MATERIALS PALETTE

The pages that follow contain the materials palette organized by element type, as well as criteria and guidelines for locating materials on the street. This chapter functions as a kit-of-parts of streetscape elements, and the previous chapter, Chapter 4, Streetscape Master Plan, sets the framework within which this kit-of-parts is applied. These two chapters should be used in tandem when considering any application of streetscape elements to Broadway between 2nd Street to Olympic.



The design inspiration for this Streetscape Plan and its materials palette draws from and seeks to showcase the iconic, historic features of Broadway, such as the lights of theatre marquees and blade signs, the silver screen, and the colorful terrazzo paving and glass block basement skylights.

## LANDSCAPE ELEMENTS

### Street Trees



*Pyrus calleryana*  
'Chanticleer' Flowering Pear



*Pyrus calleryana*  
Leaf



*Pyrus calleryana*  
Flower

### Description

The recommended street tree is *Pyrus calleryana* 'Chanticleer' Flowering Pear. It was selected for having the most qualities that best meet the needs of all of the considerations on the corridor, including it being upright (not blocking views of historic architecture and theatre marquee signs), deciduous (shade in summer, high visibility in winter), tolerance to wet soil (suitability as a street tree and for vegetated stormwater curb extensions), and multi-seasonal interest (its attractive flowers). Alternative trees are listed in the table to the left, along with their characteristics. It is not recommended to use more than one species along the corridor. Street tree selection and installation shall be subject to review and approval by the Bureau of Street Services, Urban Forestry Division.

Existing trees should be evaluated as follows: ficus should be removed due to destructive root systems; other existing species can remain in place or be evaluated for relocation along the corridor.

### Guidelines for location

There are two general conditions for locating street trees.

**Condition #1** Street trees can be located in vegetated stormwater curb extensions.

- Trees shall be placed 4' from planter edge and 4' from back of curb

**Condition #2** Street trees can be located in 4' x 8' tree pits.

- Trees shall be placed 4' from back of curb

#### Street Trees:

- shall be planted at approximately 20' intervals where possible. (See minimum clear distances from infrastructure.)
- shall be placed within the 8' sidewalk extension zone on the west side of the street in 4' x 8' tree pits placed perpendicular to the curb.
- shall be placed 4' from the existing back of curb along the east side of the street in 4' x 8' tree pits placed perpendicular to the curb.
- shall not be planted in areas where historic glass block, historic terrazo or theatre canopy exist.
- shall be installed at 36" box minimum size

#### Minimum clear distances from Infrastructure

- Water and gas meters 6'
- Driveway aprons and crosswalks 6'
- Fire Hydrants 10'
- Transit Shelters 10'
- Street Lights 20'
- Electrical Power/Utility Poles 20'
- Alley Entrances 20'
- Intersections (measured from the projected point of curb line intersections) 45'

(from Bureau of Street Services - Street Tree Division)

### Recommended Species Characteristics

	Bureau of Street Services Urban Forestry Division 'acceptable for planting in public right-of-way'	drought-tolerant	tolerant of wet soils (best for VSCEs)	appropriate for 4' x 8' tree wells	max mature height (ft)	max mature spread (ft)	deciduous	flower season	flower color	fall color
<b>Recommended Tree</b>										
<b><i>Pyrus calleryana</i> 'Chanticleer'</b>	Yes	No	Yes	Yes	40	15	Yes	spring	white	orange/red
<b>Alternative Trees</b>										
<b><i>Melaleuca quinquenervia</i></b>	Yes	Yes	Yes	Yes	20-40	15-25	No	summer/fall	white	-
<b><i>Robinia x ambigua</i> 'Purple Robe'</b>	Yes	Yes	No	Yes	40	30	Yes	spring/summer	magenta-rose	yellow
<b><i>Lophostemon confertus</i></b>	Yes	Yes	No	Yes	30-45	30	No	spring/summer	white	-



*Melaleuca quinquenervia*



*Robinia x ambigua*  
'Purple Robe'



*Lophostemon confertus*

## LANDSCAPE ELEMENTS

### Vegetated Stormwater Curb Extension



*Carex elata* 'Aurea' v. 'Bowles Golden'    *Duchesnea indica*    *Dymondia margaretae*    *Festuca glauca* 'Elijah Blue'    *Juncus patens* 'Carmen's Gray'    *Mimulus guttatus*    *Penstemon spectabilis*    *Penstemon heterophylla*    *Sisyrinchium bellum*

### Description

Plants used in the vegetated stormwater curb extensions should be:

- tolerant of seasonal flooding
- climate adapted, preferably Californian native
- installed in drifts and massed for effect
- possess a strong architectural form
- require little pruning
- less than 30" tall at maturity
- installed at 5 gallon minimum size
- planted at 20" on center

Species to consider are derived from the City of Los Angeles Bureau of Engineering Standard Plans for Green Streets, Vegetated Stormwater Curb Extension (<http://eng.lacity.org/techdocs/stdplans/s-400/s-484-0.pdf>) and are shown in the table below.

### Guidelines for Location

Vegetated stormwater curb extensions shall be located within curb extensions at intersections, mid-block crosswalks, and permanent driveways (which are driveways that provide primary access to a building or site and that can not be relocated) as conceptually shown in the illustrations to the left. Dimensions shall conform to the City of Los Angeles Bureau of Engineering Standard Plans for Green Streets, Vegetated Stormwater Curb Extension (<http://eng.lacity.org/techdocs/stdplans/s-400/s-484-0.pdf>).

Should dimensioning of vegetated stormwater curb extensions conflict with vault/elevator locations, clearance of 4'-8' shall be maintained by adjusting the dimension of the planter.

There are three general conditions for the location of vegetated stormwater curb extensions, represented in the illustrations to the left.

Condition #1 At intersections

Condition # 2 At mid-block crosswalks

Condition #3 At permanent driveways

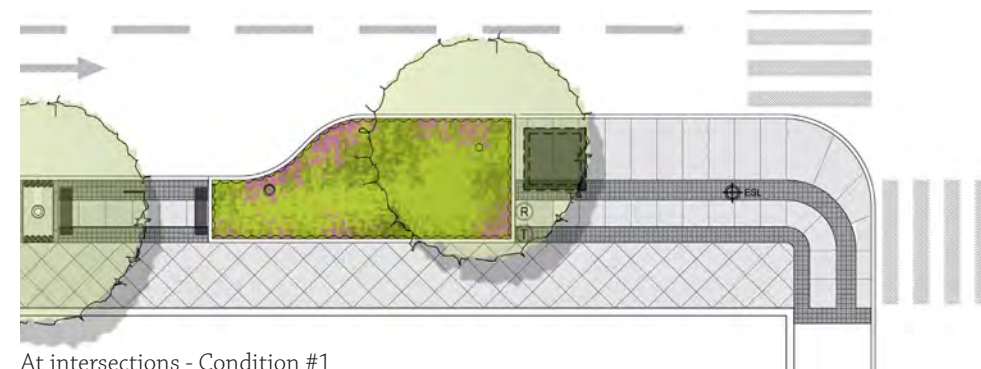

At intersections - Condition #1

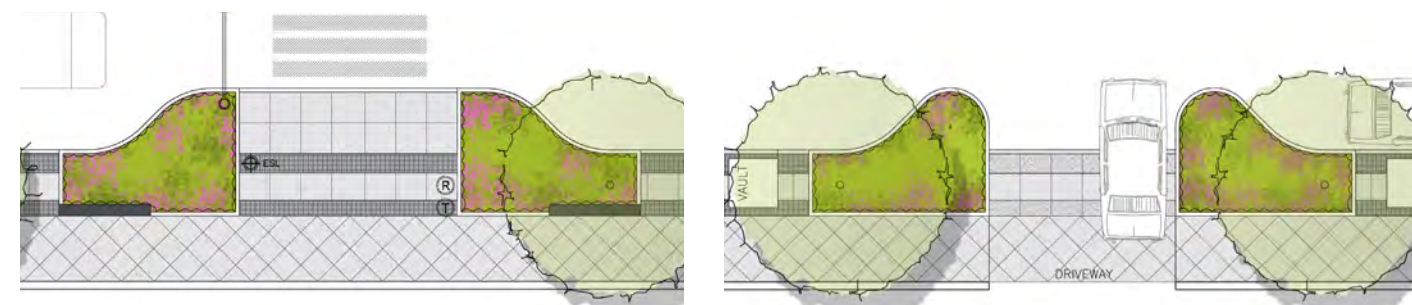

At mid-block crosswalks - Condition #2

At permanent driveways - Condition #3

### Recommended Species Characteristics

plant name	height	spread	ever-green	bloom season	bloom color	light req.	water req. (WUCOLS)
<b>Carex elata 'Aurea' v. 'Bowles Golden'</b>	12"-24"	24"-36"	Y	summer	brown	light shade - part sun	M
<b>Duchesnea indica</b>	3"-4"	indefinite by stolons	Y	spring - summer	yellow	full sun - full shade	M
<b>Dymondia margaretae</b>	<3"	to 20" by offsets	Y	summer	yellow	full sun - partial shade	L
<b>Festuca glauca 'Elijah Blue'</b>	8"-12"	8"-12"	Y	late summer	buff	full sun	M
<b>Juncus patens 'Carmen's Gray'</b>	24"-36"	indefinite by rhizomes	Y	summer	brown	full sun - part sun	n/a (water regularly)
<b>Mimulus guttatus</b>	24"	indefinite by stolons	N	spring - summer	yellow	full sun - full shade	L
<b>Penstemon heterophylla</b>	12"	24"	Y	spring - summer	purple-blue	full sun - part sun	L
<b>Sisyrinchium bellum</b>	12"-18"	6"	N	spring - summer	purple-blue	full sun - partial shade	L

## Vegetated stormwater curb extensions - drainage

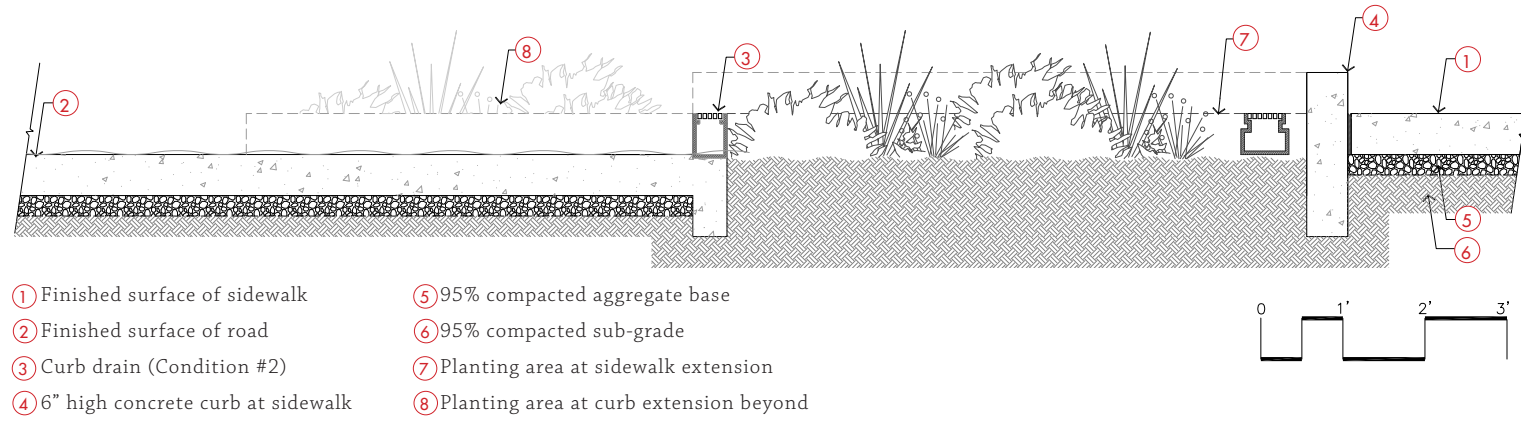

**Section A** - Vegetated stormwater curb extension and curb drain



Curb drain (Condition #2) into vegetated stormwater curb extension with metal grate

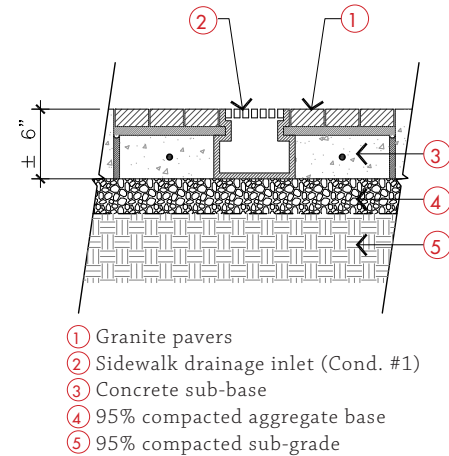

**Section B** - Sidewalk drainage inlet in granite cobble band (Condition #1)

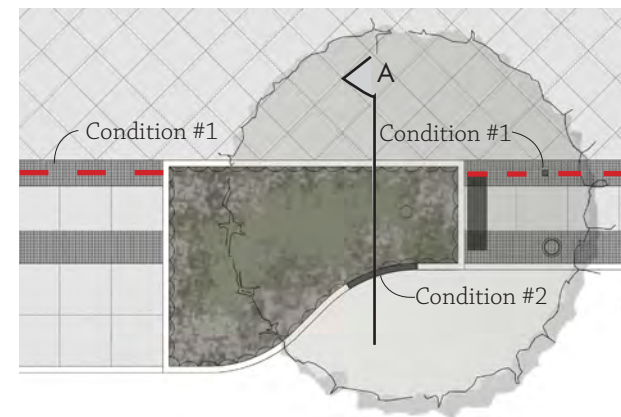

Location of sub-surface drain, sidewalk drainage inlets and curb drain at vegetated stormwater curb extension

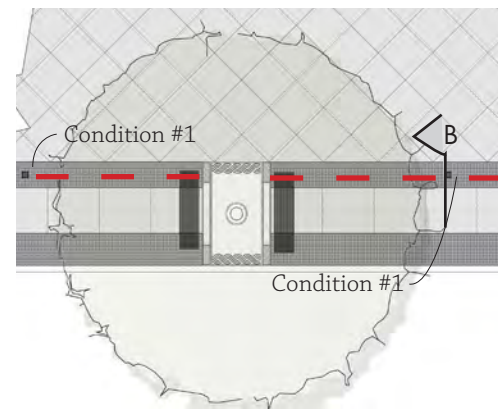

Location of sub-surface drain and sidewalk drainage inlets at tree wells

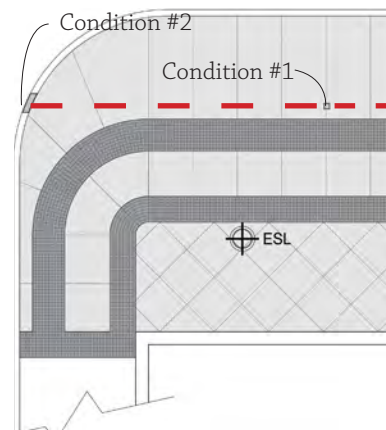

Location of sub-surface drain, sidewalk drainage inlet and curb drain at curb extensions at intersections.

— Existing Storm Water Flow Line

## Description

Although sidewalks on the west side of Broadway will extend 8' inward from the existing curb, the pattern of existing storm water flow lines will remain unchanged. These flows will be integrated in their existing location into the physical design of this new streetscape. There are two drainage strategies that will divert storm water into and out of the vegetated stormwater curb extensions.

### Condition #1 - Sidewalk Drainage Inlet

Surface drains will be covered by a 6" x 6" cast iron grate. The sub-surface drain will connect the vegetated stormwater curb extensions lengthways along the sidewalk.

Material: Black Cast Iron

### Condition #2 - Curb Drain

A 12" gap will be made in the curb at each vegetated stormwater curb extension. A 12" x 6" cast iron grate will cover the gap.

Material: Black Cast Iron

## Guidelines for location

### Condition #1 - Sidewalk Drainage Inlet

Drains will be located along existing flowlines within the 24" granite cobble band or within a field of scored concrete where curb alignment has changed.

Exact placement will be determined by civil engineer and is subject to review and approval by the Department of Public Works.

### Condition #2 - Curb Drain

One (1) 12" gap in the curb will be made at each bio-filtration planter. The gap should be located at the upstream end of the planter allowing storm-water to enter the planter.

This location of this gap and drain is especially critical where an existing gutter meets a new curb extension.

Exact placement will be determined by civil engineer and is subject to review and approval by the Department of Public Works.

## PAVING

### Paving Material 1 - Scored Concrete Field (45 degree angle)



Example of Scored Integral Colored Concrete

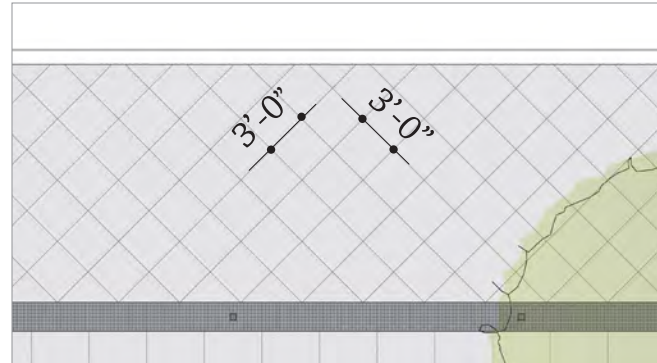

Layout of Scored Integral Colored Concrete

#### Description

Paving Material Type 1 : Scored Concrete (45 degree angle)

Color: French grey

Finish: Alternating squares of light sand blast and medium sand blast

#### Guidelines for Location

Scoring pattern: 3' x 3' squares at 45 degree angle to back of curb. Begin intersection of scores at 24" cobble band.

### Paving Material 2 - Granite Cobble



Example of Granite Cobble Band

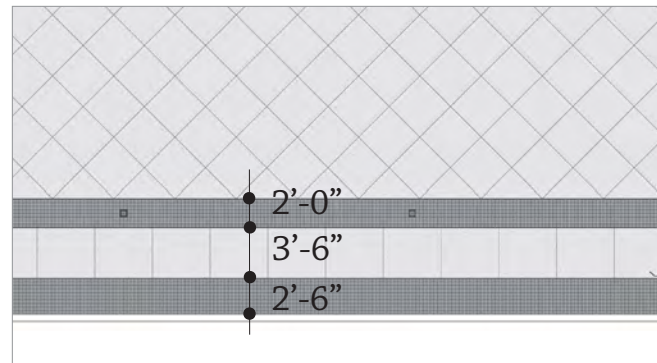

Layout of Granite Cobble Band - Condition #1

#### Description

Paving Material Type 2: 3" x 3" Granite Cobble matrix (interlocking mesh paver); thickness 1.25" - 1.5"

Color: Three color mix: Dark Grey 60%, Light Grey 30%; Mauve 10%

Finish: Flamed

Final design shall be reviewed by the Department of Public Works or the appropriate agency or department.

#### Guidelines for Location

There are two conditions where granite cobble occurs.

##### Condition #1 - On Sidewalks

There shall be two parallel bands of granite cobble separated by a 3'-6" wide band of scored concrete

Curbside band (located immediately adjacent to back of curb) : 2'-6" wide

Inside band: 2'-0" wide

##### Condition #2 - At alley or paseo thresholds

There shall be one 2'-0" wide band of granite cobble beginning at the corners of alleys or paseos and extending into the alley.

An alley identity plaque will be placed centrally into the band. See signage section.

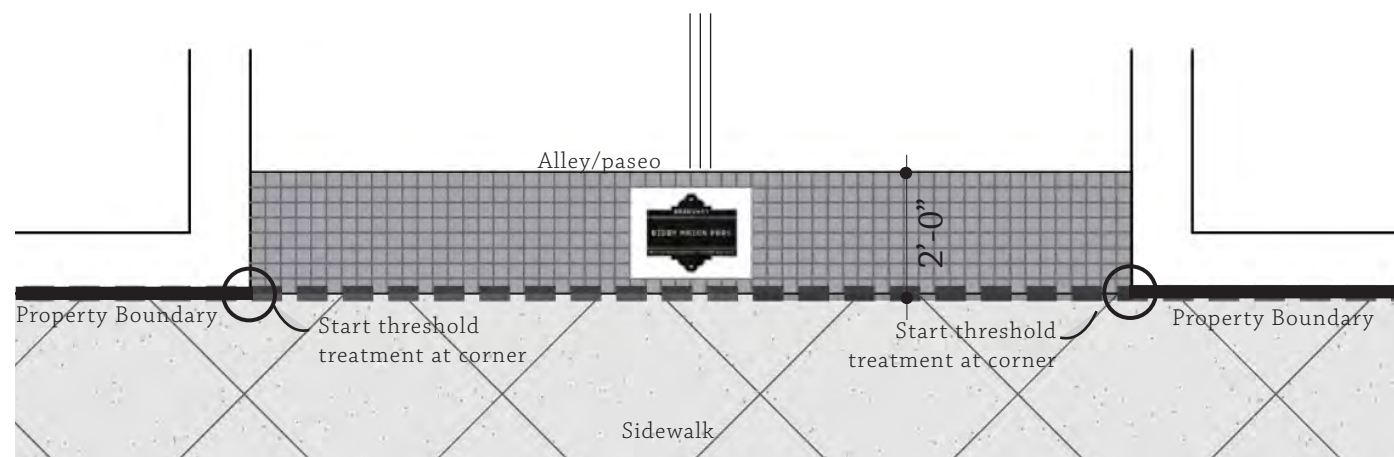

Layout of Granite Cobble Band at paseo thresholds - Condition #2

**PAVING**

**Paving Material 3 - Concrete Band at Existing Historic Element**

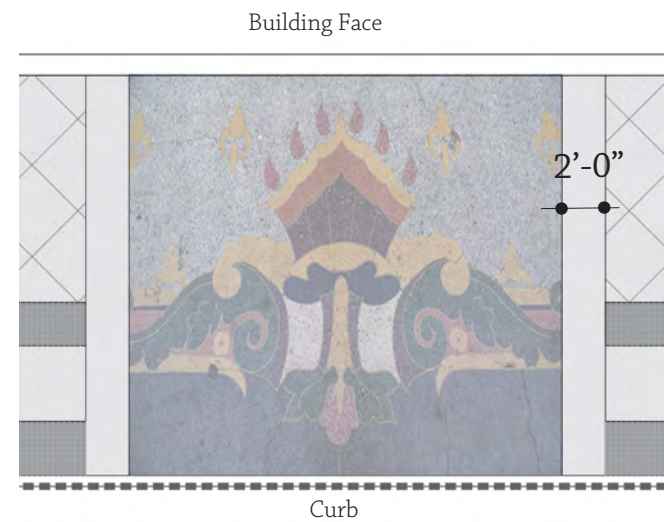

#1 East Side : concrete band at existing historic element when element runs to back of curb

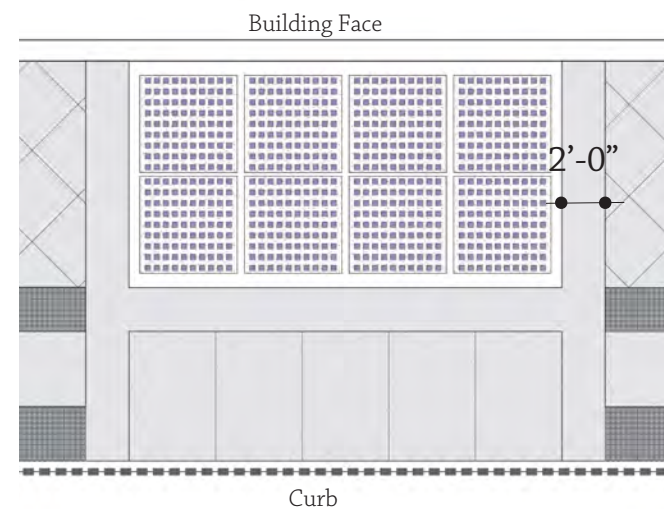

#3 East Side : concrete band at existing historic element when element runs only partway to back of curb

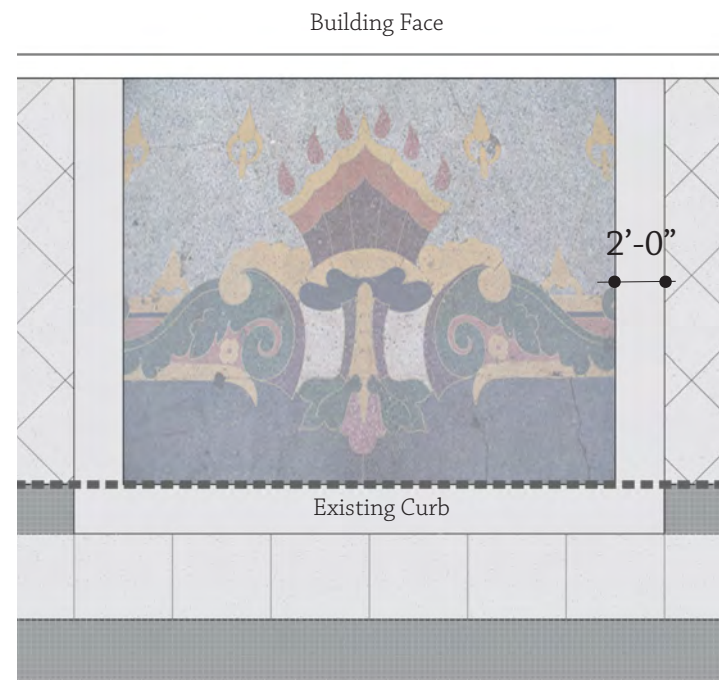

#2 West Side : concrete band at existing historic element when element runs to back of existing curb

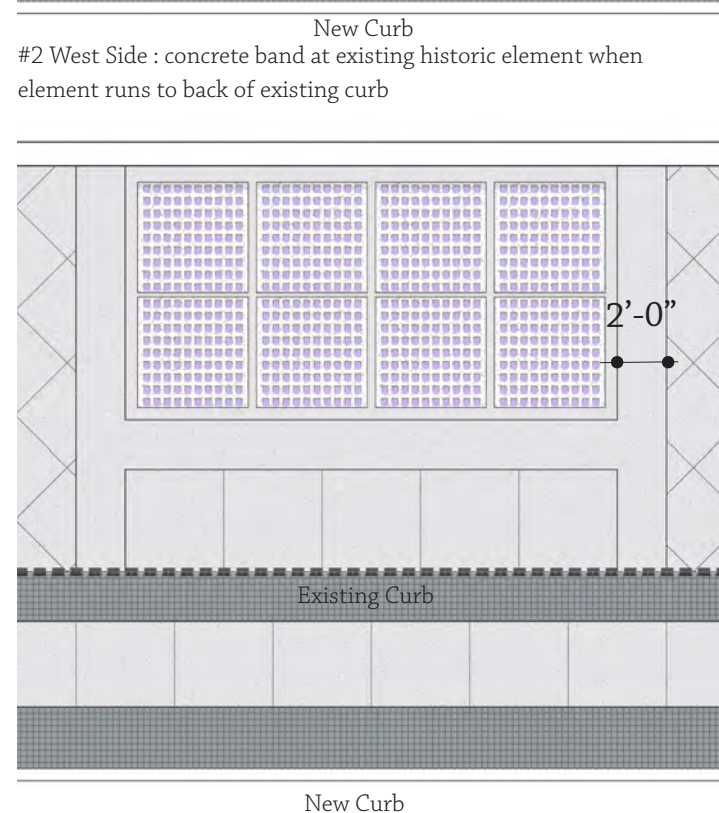

#4 West Side : Concrete Band at Existing Historic element when element runs only partway to back of curb

**Description**

Paving Material Type 3 : 2' wide concrete band to border existing historic element (terrazzo, glass-block or tile). No historic element should be damaged or removed as part of concrete border installation.

Color: French grey

Finish: Light sand-blast

**Guidelines for Location**

There are four general conditions for the location of these concrete bands

Condition #1 East side: Concrete band shall border two sides of the existing historic element when that element runs to back of curb.

Condition #2 West side : Concrete band shall border three sides of existing historic element when that element runs to back of existing curb.

Condition #3 East side : Concrete band shall border three sides of existing historic element and continue to curb when element runs only partway to back of curb.

Condition #4 East side : Concrete band shall border three sides of existing historic element and continue to cobble when that element runs only partway to back of existing curb.

**Resources**

See the HPSR in the Appendix of this document for more a detailed discussion on the restoration of glass block basement skylights (sidewalk vault light panels) along Broadway and helpful resources.

Also refer to the HPSR in the Appendix of this document for a list of addresses for buildings with contributing historic terrazzo, a more detailed discussion on terrazzo along Broadway and helpful resources.

## Paving Material 4 - Scored Concrete at 90 degrees

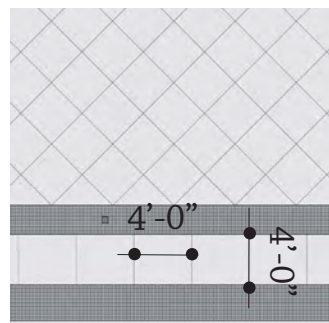

Layout of Scored Concrete at 90 degrees - Condition #1

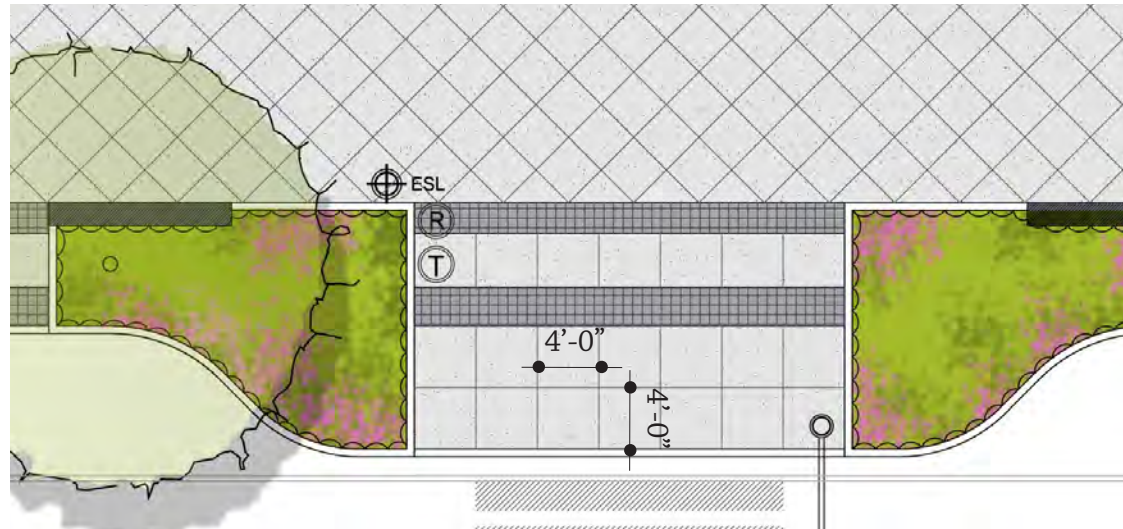

Layout of Scored Concrete at 90 degrees - Condition #2

### Description

Paving Material Type 4 : Scored Concrete

Color: French grey

Finish: Light sand-blast

### Guidelines for Location

Scoring pattern: 4' x 4' squares at 90 degree angle to back of curb

There are two general conditions for the location of this scoring pattern.

#### Condition #1

A single row along back of curb between two granite cobble bands.

#### Condition #2

A double row along back of curb at mid-block crossing.

## Paving Material 5 - Painted Continental Crossing



Example of Painted Continental Crossing

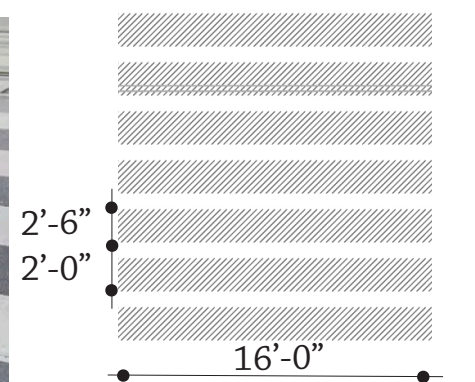

Layout of Painted Continental Crossing

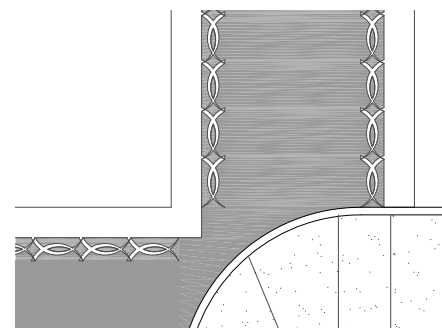

Optional Pattern to Recommended Continental Crossing: Solid Field with Perimeter Duratherm Detail

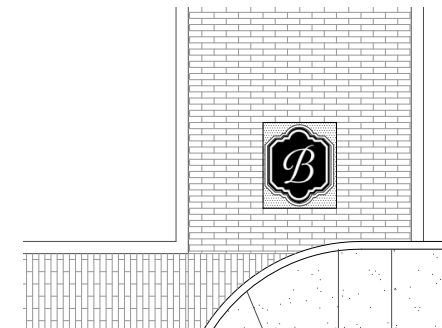

Optional Pattern to Recommended Continental Crossing: Duratherm with Broadway "B"

### Description

Paving Material Type 5 : Duratherm

Color: White

### Guidelines for Location

Painted crosswalks to be located at all crossings- intersections and mid-blocks.

Pattern: 2'-0" wide x 16'-0" long painted bands.

2'-6" gaps between the parallel bands.

## Paving Material 6 - Painted Curb Extensions

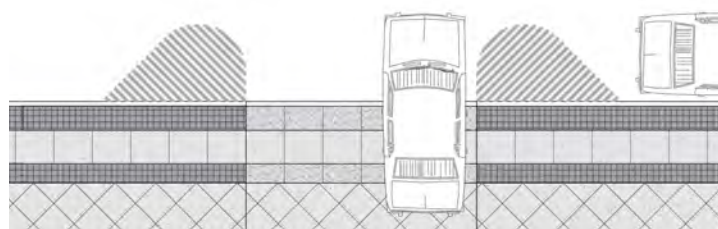

Painted curb extensions at temporary driveways

### Description

Paving Material Type 6 : Duratherm

Color: White

### Guidelines for Location

Driveways that are currently functioning, but that can be phased out in the future and relocated to side streets or alleys, will be flanked by painted and striped bulb-outs.

## FURNISHINGS

### Transit Shelters (Conceptual Design)

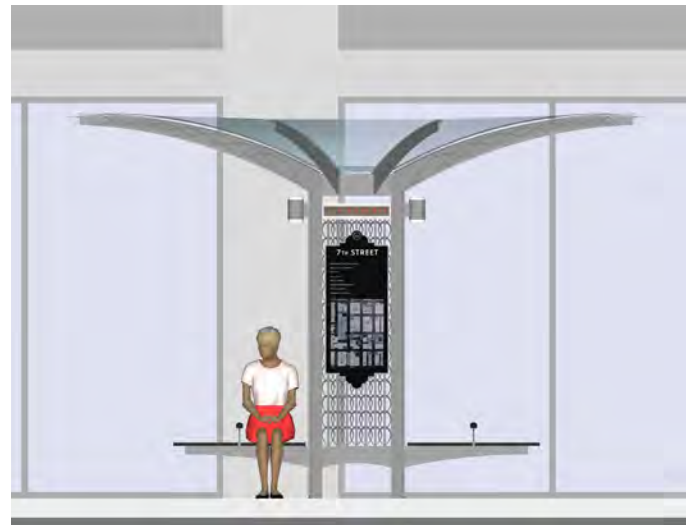

Elevation 1



Elevation 2

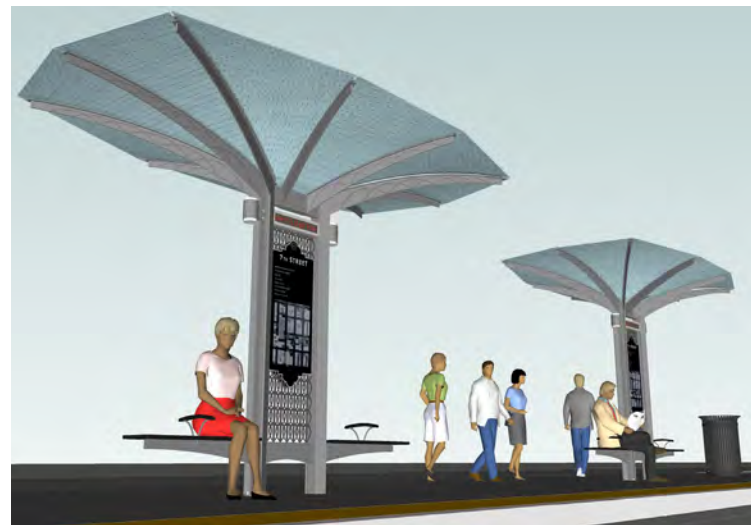

Transit Shelter Design

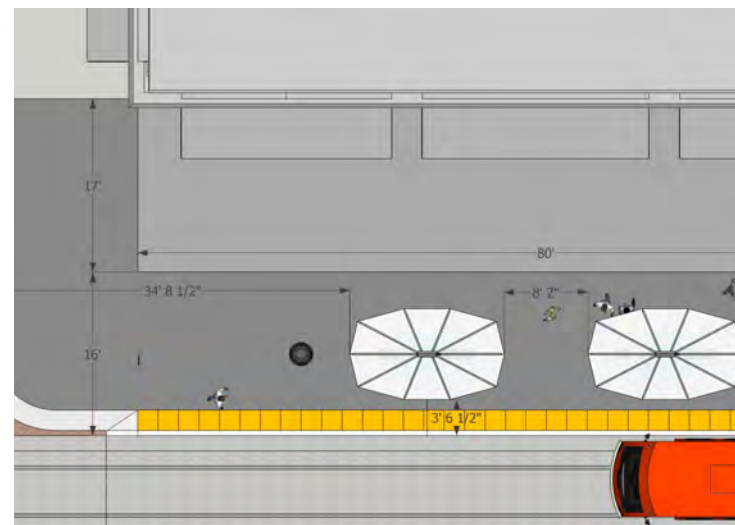

Transit Shelter Dimensioning



Other Perspectives



### Description

Transit stops with shelters shall be located at nearside curb extensions on the west side of Broadway to accommodate both buses and the planned southbound-running restoration of historic streetcar service. As a rule, transit shelters will only be provided for transit stops at nearside curb extensions on the west side of Broadway. See Chapter 4 for an overview of the streetscape elements that comprise transit stops along Broadway.

The Broadway station shelter is inspired by the Art Deco design period which is present in the styles of the many theatres on Broadway. Transit shelters shall be coordinated with any existing City street furniture contract.

Subject to review and approval by the Department of Public Works, shelter design components include the following:

- The main steel posts of the structure are composed of structural steel I-beams which continue to be the profiles of the canopy, and have an elegant radius. Rainwater is collected in the center of the canopy and led along the inside of the posts in a tubular water spout.
- A vertical screen between the posts composed of welded steel strips, and powder coated in black, has an Art Deco pattern.
- The canopy beams are painted using a similar pattern.
- The panels of the canopy consist of 3Form Coda XT polycarbonate curved panels, which have a pattern etched or applied as a foil on them. These panels are made with 40% pre-consumer recycled content.
- The signage blade mounted on the vertical screen includes an area map and schedules of the streetcar. A variable message board is mounted on top of the screen. On the building side of the signage blade, historical Broadway information will be presented. See signage details for “history walk” on page 19 of this chapter.
- The 2 person bench adjacent to the canopy structure is made of steel and powder coated in a black color.
- Up and downward lighting in the shelter is provided by 2 metal cones that are mounted adjacent to each side of the canopy structure

### Guidelines for Location

Two shelters shall be located at each nearside curb extension transit stop on the west side of Broadway. The first shelter from the intersection shall be located a minimum of 34'-8 1/2" from cross street curb. The second shelter from the intersection shall be located 8'-2" from the first shelter. Both shelters shall be located so that a minimum clear distance of 3'-6 1/2" is maintained from the edge of canopy to the face of curb. In the event that subsequent shelters are needed, they shall be located according to the dimensions above.

## FURNISHINGS

### Bench - Full (Conceptual Design)



#### Description

Product: Victor Stanley Framers Modern Series (FMS-324) 6' long

Color: Black Powdercoat

#### Guidelines for Location

There are two typical locations for this bench, subject to review and approval by the Department of Public Works.

Location #1: On either side of tree wells perpendicular to street and aligned to center of tree well. Back of bench shall be placed approximately 12" from edge of tree grate.

Location #2: At far ends of vegetated stormwater curb extensions at intersections only perpendicular to street. Back of bench shall be placed approximately 8" from edge of planter curb.

### Alcove - Single Chair (Conceptual Design)

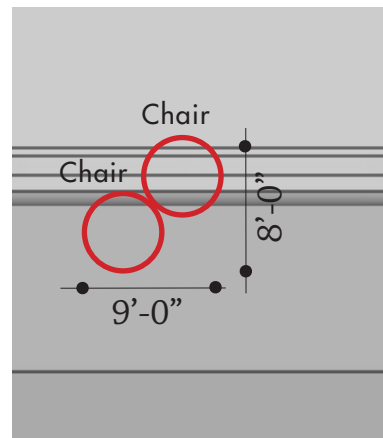

Plan of Alcove depicting chair locations

#### Description

Product: Victor Stanley Framers Range Custom Single Chair (based on FMS-324) 18" wide.

Color: Black Powdercoat

#### Guidelines for Location

This chair is located in the alcoves at the end of each station platform, subject to review and approval by the Department of Public Works. In each alcove there shall be two single chairs separated by a bollard.

### Alcove - Bollard (Conceptual Design)



Option 1 - Bollard with integrated symmetrical light



Option 2 - Bollard with integrated single-direction light

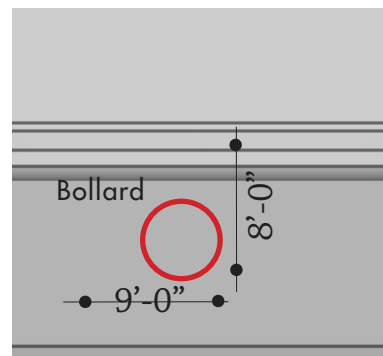

Plan of Alcove depicting bollard location

#### Description

Product: BEGA Bollard with integrated light

Color: Black

Dimension: Option 1 - 15 3/4" x 15 3/4" x 18"  
Option 2 - 15 3/4" x 18" x 4 3/4" x 9 1/2"

#### Guidelines for Location

A bollard is located in the alcoves at the end of each station platform, subject to review and approval by the Department of Public Works. In each alcove there shall be one bollard flanked by two single chairs.

## FURNISHINGS

### Seat Wall at Mid-block Crossing (Conceptual Design)

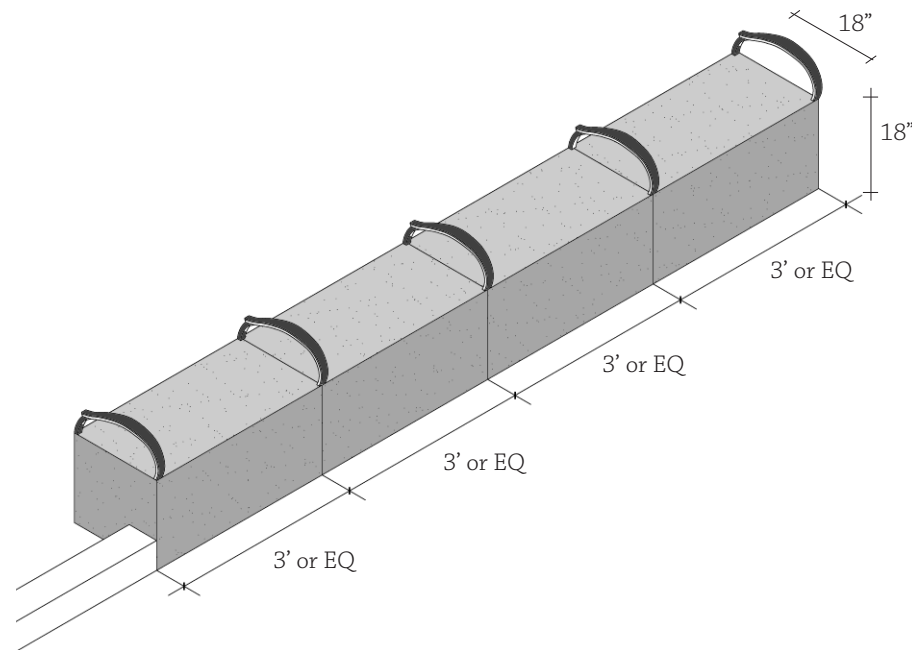

#### Description

Furnishing: Custom Seat Wall

Material: Pre-cast concrete bench with custom cast iron arms. Arms to emulate arms from Victor Stanley Framers Modern series.

Dimensions: 12' long (4 x 3' segments) x 18" wide x 18" high

Color: Natural concrete with black arms

Finish: Light sand-blast to concrete with powdercoated arms; graffiti coating recommended

#### Guidelines for Location

This seat wall is located along property line edge of the mid-block vegetated stormwater curb extension at mid-block crosswalk only. The seat wall shall sit within the planter. The face of the seat wall shall sit flush with the edge of the sidewalk.

### Tree Grate (Conceptual Design)

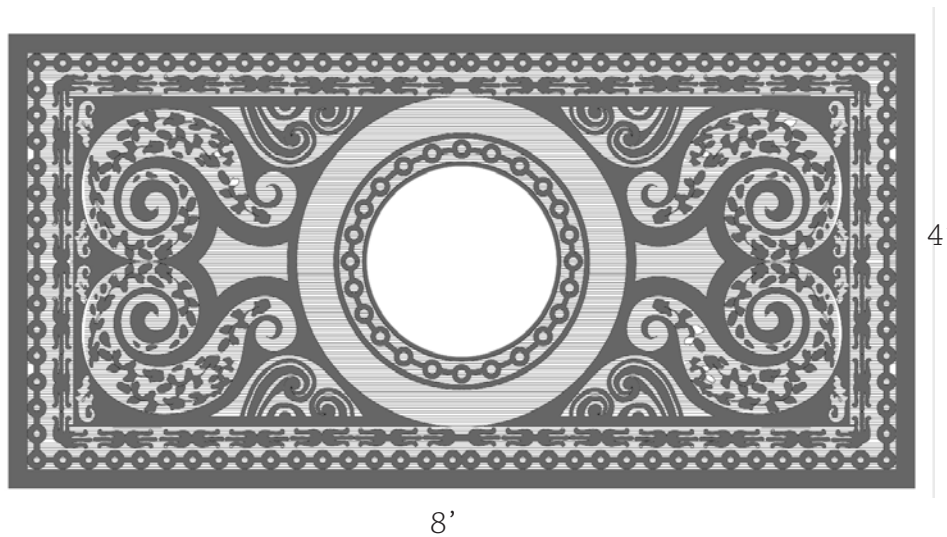

#### Description

Furnishing: Custom Tree Grate

Material: Cast Iron

Dimensions: 4' x 8'

Color: Black Powdercoat

#### Guidelines for Location

This tree grate is located at tree wells.

## FURNISHINGS

### Bike Rack (Conceptual Design)

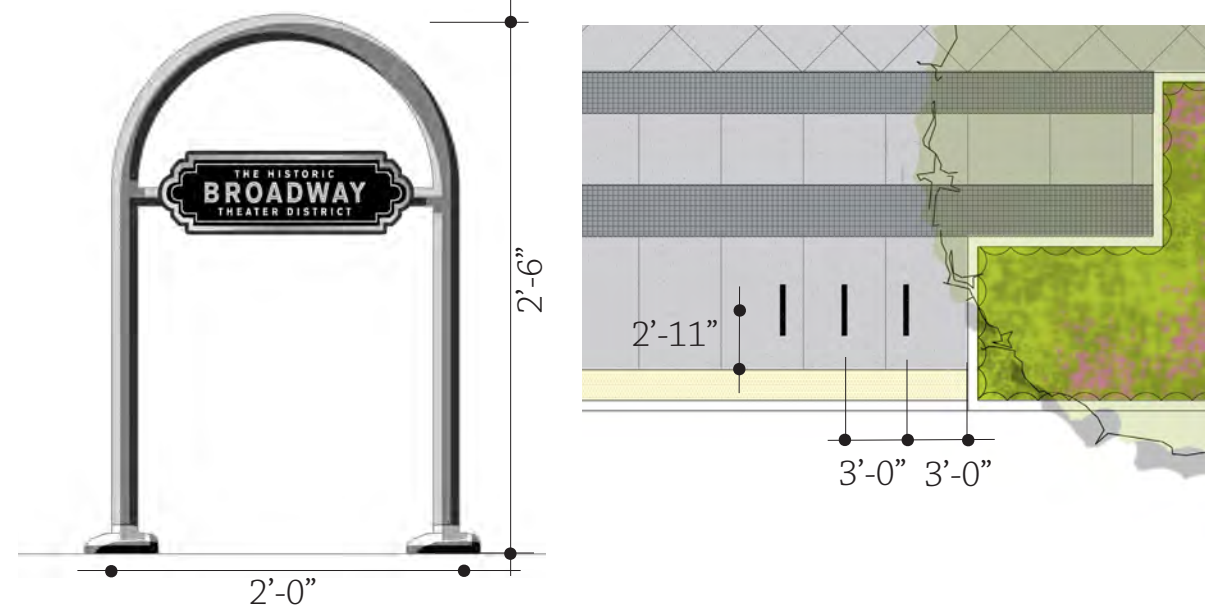

Custom Bike Rack

Typical Location of Bike Racks

### Description

Product: Custom Cast Iron U shaped tube bike rack with Broadway district identity signage mounted to both sides of rack.

Dimension: 2'-0" x 2'-6"

Color: Black

Finish: Powdercoat

### Guidelines for Location

Bike Racks shall always be located at right angles to street. Center of bike rack shall be placed no closer than 4'-6" from back of curb.

When bike racks are grouped together they should be placed at 3'-0" on center and no closer than 3'-0" to a planting area.

Bike Racks shall be located at:

- Streetcar/bus platform - group of three (3)
- Bus platform - group of three (3)
- Far side of Mid-block crosswalk - single (1)
- At Pedestrian Platform - single (1)

See Figure X in Chapter 4 for general locations.

### Trash Receptacle (Conceptual Design)



### Description

Product: Victor Stanley Ironsites Series Side-door Litter Receptacle

Color: Black

Finish: Powdercoated

### Guidelines for Location

Trash receptacles and recycling receptacles are located in pairs at corners and at mid-block crosswalks. See Figures 4-7 and 4-8 in Chapter 4 for general locations.

## FURNISHINGS

### Kiosk (Conceptual Design)



#### Description

Product: Custom built compact kiosk design. Shall be coordinated with any existing City street furniture contract.

Lockable steel kiosk with glass display panels - Min. 50% transparency on front side of kiosk

Size: No larger than 8' wide x 8' deep x 8' high

Color: Black Powdercoat

Design of kiosk shall be in keeping with the furnishings palette's emphasis on reflecting a modern interpretation of traditional style

Kiosks can be used for coffee carts, information kiosks, flower carts and news stands

Outfit for electrical and water as needed

Final design shall be reviewed by the Department of Public Works.

#### Guidelines for Location

Kiosks can be placed in two (2) possible locations and installed as necessary.

Condition #1: South end of mid-block vegetated stormwater curb extension on the west-side of street. Position perpendicular to the street facing outward from vegetated stormwater curb extension.

Condition #2: At non-transit curb extension along east-side of street. Position perpendicular to the street facing outward from vegetated stormwater curb extension towards intersection.

See Figure X in Chapter 4 for general locations.

## FURNISHINGS

### News Rack

#### Description

Product: Custom built compact news rack. Shall be coordinated with any existing City street furniture contract.

Size: Shall be designed with regard to basic conventions

Color: Grotto Black as per city code LAMC Section 42.00

Design of the newsrack shall be in keeping with the furnishings palette's emphasis on reflecting a modern interpretation of traditional style

Final design shall be reviewed by the Department of Public Works.

## LIGHTING

### Existing & Proposed Street Lights

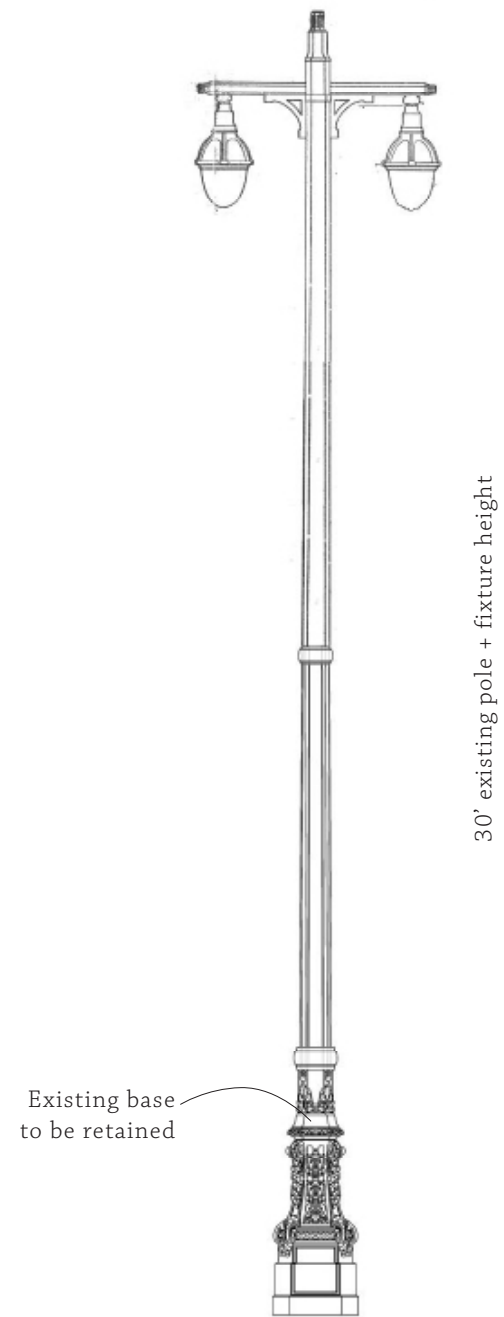

Existing street lighting poles to remain in place. Existing base to be maintained. Existing lights to be replaced with LED fixtures

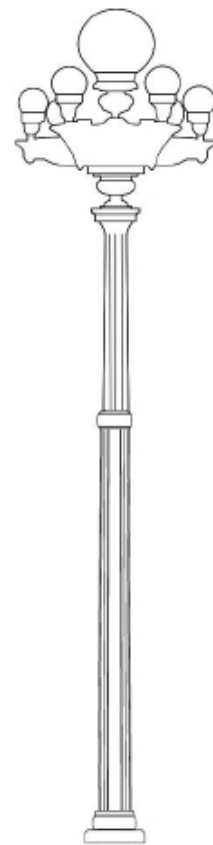

Proposed pedestrian scale street light to be a replica of the historic Llwellyn Globe-7, pre-1920's fixture.

#### Description

Existing Street Light locations shall be retained. The historic bases of these existing street lights will also be retained.

Proposed Infill Street Lights are to be added to sidewalk. These lights will be replicas of the historic street lights also.

#### Guidelines for Location

Street light placement takes precedence over placement of any other new component proposed as part of this Plan.

Proposed streetlights shall be located midway between existing street lights at back of curb per Bureau of Street Lighting.

New street lights at corners shall be placed as follows:

- At streetcar platform: 60' from existing traffic light/street light located at north-west corner
- At bus platforms: 30' from existing traffic light / street light located at north-east and south-west corners
- At pedestrian platform: 60' from existing traffic light / street light located at south-east.

Where new street lights fall in high pedestrian traffic zone, such as the middle of a mid-block crossing path of travel, the light shall be re-positioned to the nearest accommodating location.

## COLOR & TYPOGRAPHY

### Primary Color Palette



C1 SILVER



C2 BLACK

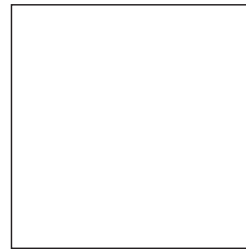

C3 WHITE

### Secondary Color Palette



C4 PMS 1975C



C5 PMS 2727C



C6 PMS 7409C

LOGO - Akzidenz Grotesque BE Bold

**ABCDEFGHIJKLMNOPQRSTUVWXYZ**  
**abcdefghijklmnopqrstuvwxyz**

WAYFINDING LOGO - Coperplate Gothic TwentyNineAB

ABCDEFGHIJKLMNOPQRSTUVWXYZ  
ABCDEFGHIJKLMNOPQRSTUVWXYZ

WAYFINDING LOGO, TEXT, RADIO TOWER - BaseNine Regular

ABCDEFGHIJKLMNOPQRSTUVWXYZ  
abcdefghijklmnopqrstuvwxyz

### Description

Broadway's primary color palette is silver, black and white. This color palette reflects project's Vision for Broadway - "An American Brand", as the colors represent black and white films of Broadway's history. Its simplicity also reflect one of the project's Design Principles - "keep it simple". The palette allows various streetscape components to bring simplicity and unity to a street filled with many uncoordinated colors. There are three colors in secondary color palette to accent the primary colors.

## IDENTITY, WAYFINDING & INFORMATION

### District Identity



#### Description

Where traffic regulation allows for flexibility in design, the new District Identity signs shall replace existing signs. These signs help create unified identity to Broadway.

Dimension: 3'-0" w, 9" h. Verify dimension of existing signs.

Color: Black, silver, white, and red.

Materials: Aluminum with Matthews paint, reflective copy.

#### Guidelines for Location

With the new street configuration and light pole locations, signs shall be installed on new light poles near the curb on Broadway from 2nd to 9th Street.



#### Description

The name "The Historic Broadway Theatre District" appropriately represents the vision for this revitalized district.

The logo reflects the project's Vision for Broadway - "An American Brand", by conveying the theatre experience and the classic imagery associated with Broadway. This logo conjures up Golden Era theatre marquees and signage.

## IDENTITY, WAYFINDING & INFORMATION

### Downtown Sign System



### Vehicular Wayfinding

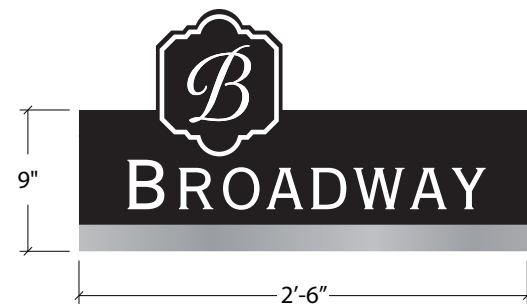

### Description

As an addition to LA Downtown Walk family of signs, “Broadway” shall be one of downtown’s officially recognized districts as shown above left. “Broadway” shall replace the “Historic Downtown” identity on Broadway between 2nd Street and Olympic.

Dimension: 2'-6" w, 9" h. Verify dimension of existing signs.

Color: Black, silver, white.

Materials: Aluminum with Matthews paint, reflective copy.

### Guidelines for Location

With the new street configuration and light pole locations, signs shall be installed on new light poles near the curb on Broadway from 2nd to 9th Street. Replace top portion with the new “Broadway” identity.

## IDENTITY, WAYFINDING & INFORMATION

### Pedestrian Wayfinding

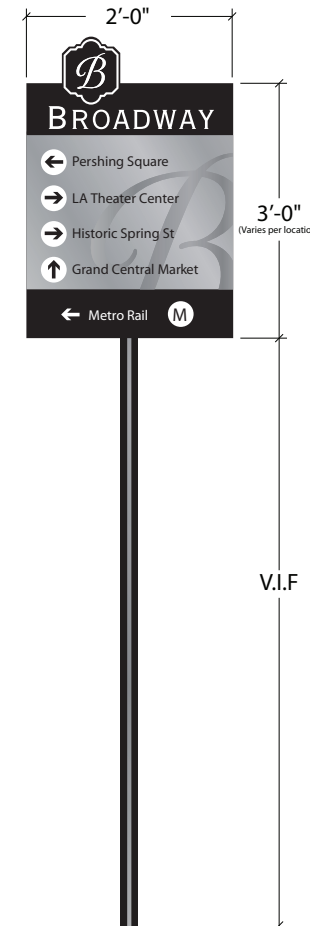

### Description

The new pedestrian wayfinding with unique Broadway Identity, as part of LA Downtown walk signs, shall replace all existing pedestrian wayfinding signs.

Dimension: 2'-0" w, 3'-0" h sign panel. Verify dimension of existing signs.

Color: Black, silver, white.

Materials: Aluminum with Matthews paint, silkscreened copy. Etched cursive "B".

### Guidelines for Location

With the new street configuration, signs shall be relocated on near the curb on Broadway from 2nd to 9th Street.

## Parking Regulations

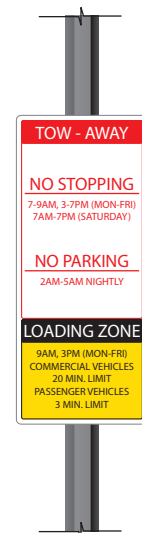

### Description

A more streamlined system of parking regulation signs shall replace existing regulation signs on Broadway from 2nd to 9th Street. The signs shall conform to MUTCD regulations.

### Guidelines for Location

With the new street configuration, all parking regulation signs shall be relocated to near the curb in parking zones. Install on new posts. Avoid installing on light poles.

## IDENTITY, WAYFINDING & INFORMATION

### Street Markers (Conceptual Design)

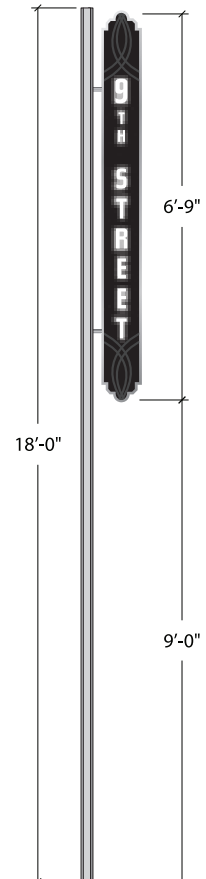

#### Description

The new Street Markers shall be internally-lit signs mounted on octagonal shaped steel posts.

Dimension: 18'-0" to top of post  
8'-0" blade sign height  
5" dia. octagon post

Color: Black silver post & silver blade sign  
with white acrylic letters

Materials: Steel post - powdercoat silver  
Sign - Aluminum with Matthews paint,  
internally-lit white acrylic letters

#### Guidelines for Location

Sign shall be mounted on Broadway between 2nd to 9th, near the street corners adjacent to streetcar stations.

## Streetcar Info & Schedules/History Walk



#### Description

Streetcar Schedule will face the street and History Walk will face the buildings. The sign shall be integrated into metal patterned grill portion of each transit shelter.

Dimension: TBD

Color: Black, silver, white.  
Materials: Aluminum, etched and filled with Matthews paint,  
raised and painted copy.

#### Guidelines for Location

Sign shall be integrated into each transit station.

## IDENTITY, WAYFINDING & INFORMATION

### Historic Building Marker

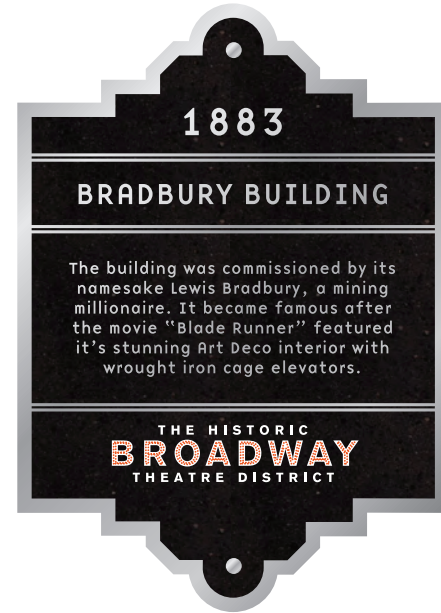

#### Description

The new Historic Building Markers shall provide following information:

- Year when building opened
- Name of building
- Brief history of building, including name of architect
- “The Historic Broadway Theatre District” logo

Dimension: 1'-0" w, 1'-6" h

Color: Black, silver, and red.

Materials: Aluminum, etched background filled with black Matthews paint, raised copy.

#### Guidelines for Location

Sign shall be placed on walls or columns on major historic buildings. Each sign and content to be coordinated with building owner.

- 5'-0" from finished floor to the center line of sign. Exact location of signs to be coordinated with building owner and subject to review and approval by Department of City Planning staff for compliance with the Broadway CDO.

### Paseo Marker



#### Description

The new Paseo Marker shall indicate all entries into public paseos on or adjacent Broadway, such as Biddy Mason Park.

Dimension: 2'-0" w, 1'-6" h

Color: Black, silver

Materials: Aluminum with black terrazzo

#### Guidelines for Location

Embedded into tiled floor or other materials on all entries into public paseos. To be coordinated with owners.

## IDENTITY, WAYFINDING & INFORMATION

### Banners



#### Description

The Banners shall be installed on temporary basis and shall be replaced seasonally, periodically, or annually with various design options.

Dimension: 2'-0" w, 6'-0" h

Design: Varies per option

Material: Digitally printed vinyl

#### Guidelines for Location

The banners shall be installed on all new light poles on Broadway between 2nd & 9th.

## IDENTITY, WAYFINDING & INFORMATION

### Radio Tower



#### Description

Rebranding the existing Radio Tower on Broadway with “Broadway” letters could act as a beacon for the street and district. Recommended letters would be open face channel letters, lit with bulbs. The tower itself could be lit with jewel-like intermittent LED bulbs located seemingly in random manner throughout. LED color-changing flood lighting would be placed throughout the tower-facing interior as “core” lighting. LED “sphere” lighting could be placed at top of tower. Coordination with building owner required.

Alternately, the existing radio tower’s KRKD lettering could be illuminated, as well as the tower itself, as described above.

As these suggested ideas for enhanced identity fall within the private realm, implementation would need to be coordinated with regulations provided by a Broadway Sign District.

#### Guidelines for Location

There are two existing Radio Towers, one on Broadway, the other on Spring, between 5th & 6th Streets. The proposed Broadway Radio Tower identity would utilize the existing tower on Broadway, currently showing the letters KRKD.

Refer to Broadway Sign District ordinance further guidance or standards.

### Rooftop Sign



#### Description and Guidelines for Location

Branded Rooftop Signs would act as the gateway into the Historic Broadway Theatre District. The shown sign is on 2nd street on Broadway facing south. Coordination with building owners and engineers is required. The sign structure would be designed per structural requirements and calculations and will resemble historical theatre rooftop sign structure. The letters would be made of open channel aluminum and be internally-lit with color changing LED bulbs or translucent acrylic face as an option.

As these suggested ideas for enhanced identity fall within the private realm, implementation would need to be coordinated with regulations provided by a Broadway Sign District.

## IDENTITY, WAYFINDING & INFORMATION

### Sign Location Plan - Typical Block

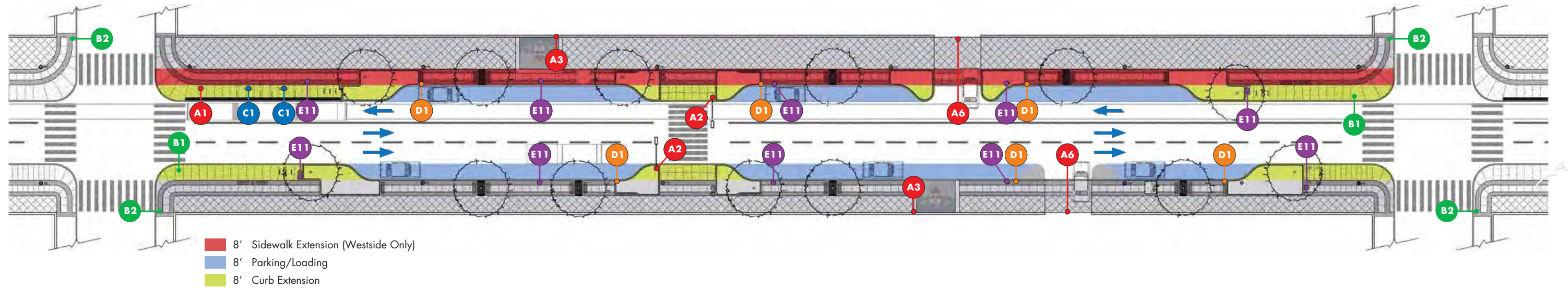

## Sign Legend

IDENTITY SIGNS	DIRECTIONAL SIGNS	INFORMATION SIGNS	REGULATION SIGNS	AMENITIES
<b>A1</b> STREET MARKER ID	<b>B1</b> PEDESTRIAN DIRECTIONAL	<b>C1</b> INFO & MAP @ TRANSIT SHELTER	<b>D1</b> REGULATION SIGNS	<b>E11</b> BANNERS
<b>A2</b> DISTRICT ID	<b>B2</b> VEHICULAR DIRECTIONAL			
<b>A3</b> HISTORIC BLDG. MARKERS - WALL MOUNT				
<b>A4</b> PASEO MARKERS (NOT SHOWN)				
<b>A5</b> PUBLIC PARKING LOT ID (NOT SHOWN)				
<b>A6</b> PUBLIC PARKING STRUCTURE PARKING ID				

## VISUAL SUMMARY OF CONCEPTUAL STREETScape ELEMENTS

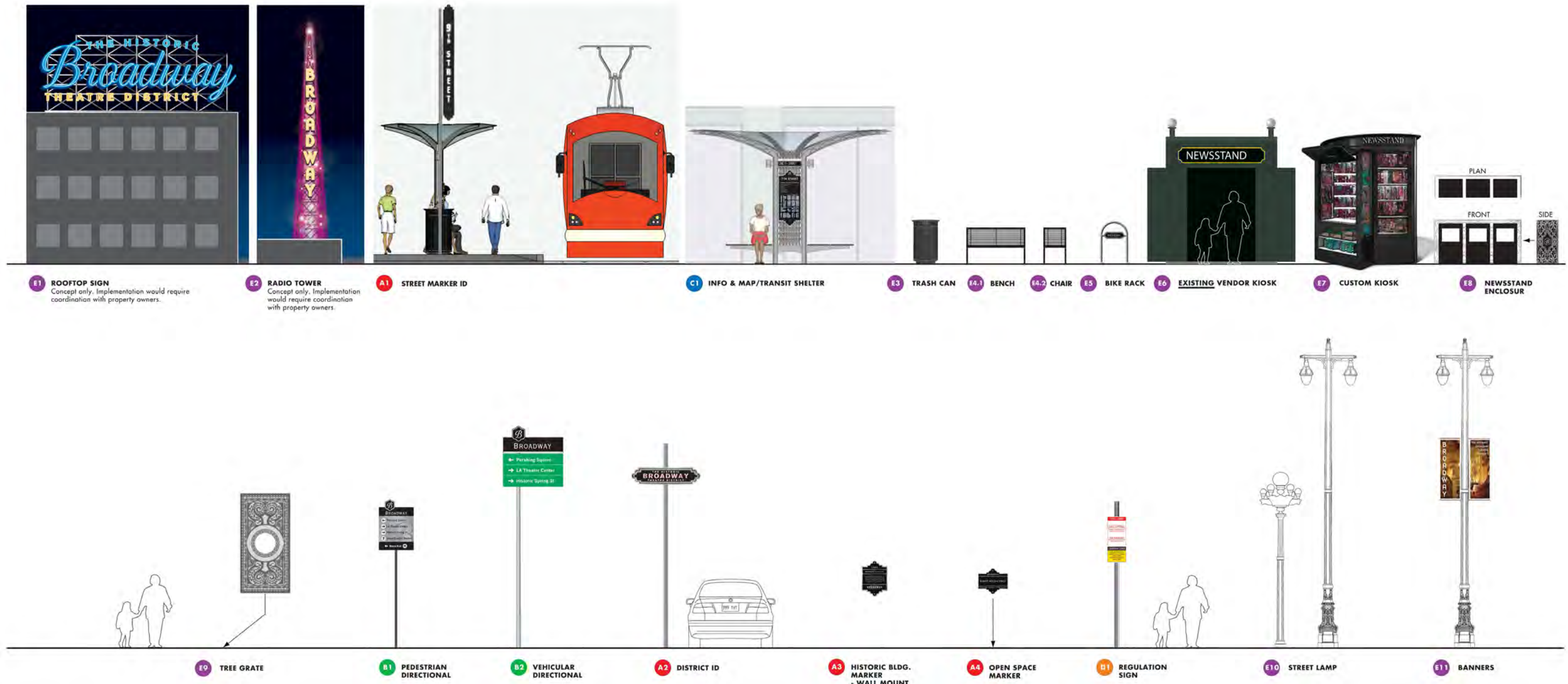

THIS PAGE IS INTENTIONALLY BLANK

## 6.0 IMPLEMENTATION STRATEGY & PHASING

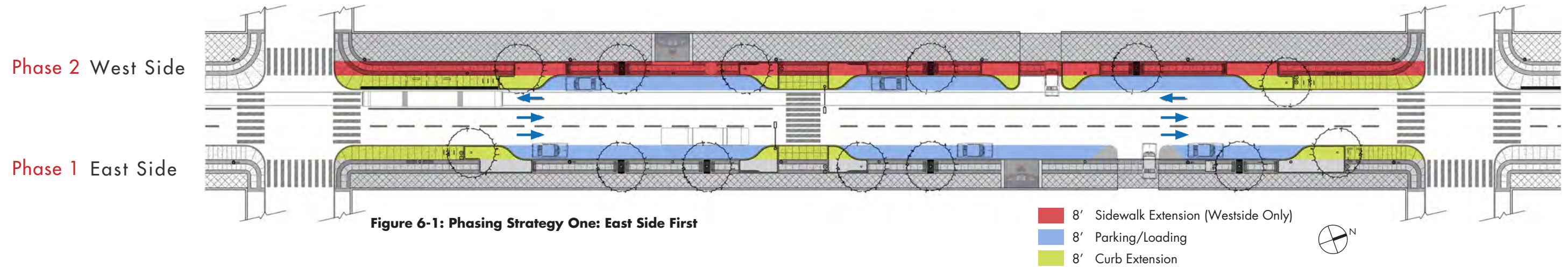

### PHASING

Although construction of the improvements called for in this Streetscape Master Plan may occur concurrent with construction of the proposed restoration of historic streetcar service, it is not dependent on it. A phased approach to implementation is possible as funding becomes available. This Plan proposes a phasing strategy in which the East side of Broadway is constructed first, followed by the West side (concurrent with the construction of the southbound-running restoration of historic streetcar service, if feasible), described below as Strategy One. However, both sides of Broadway could be constructed simultaneously if necessary, detailed as Strategy Two below.

#### Strategy One - East Side First

In Strategy One, the East side of Broadway is constructed first, followed by the West side concurrent with the construction of the southbound-running restoration of historic streetcar service, as depicted in Figure 6-1. For each side, or phase, the entire length of the project area is constructed simultaneously, or could be phased by block.

**Phase One** – Because the East side of Broadway requires no change to the location of the curb, the physical design features for the reconfiguration of Broadway can be applied first on this side of the street, including the

construction of curb extensions. No impacts to traffic will occur but restriping of the roadway may be necessary to accommodate current traffic patterns, which consists of three lanes northbound and two southbound. Restriping to preserve this traffic pattern, however, would require the removal of the 8' parking/loading “ghost lane” from service. See Chapters 3 and 4 for more information on the existing traffic pattern and lane configuration.

**Phase Two** – The construction of the West side of Broadway, in which the trackbed and other infrastructure for the south-bound running restoration of historic streetcar service is located, can occur second, concurrent with streetcar implementation. It is not dependent on streetcar implementation - only supportive of it. This Plan calls for an 8' sidewalk extension on the West side of Broadway only to accommodate the restored historic streetcar service, requiring the shifting of the existing curb 8' into the roadway. Although storm water drainage will be accommodated at the existing flow-line, the physical design will impact the number of travel lanes, reducing them from 4 to 3.

#### Strategy Two - Both Sides Simultaneously

East and West sides could be constructed simultaneously, and occur in phases block by block.

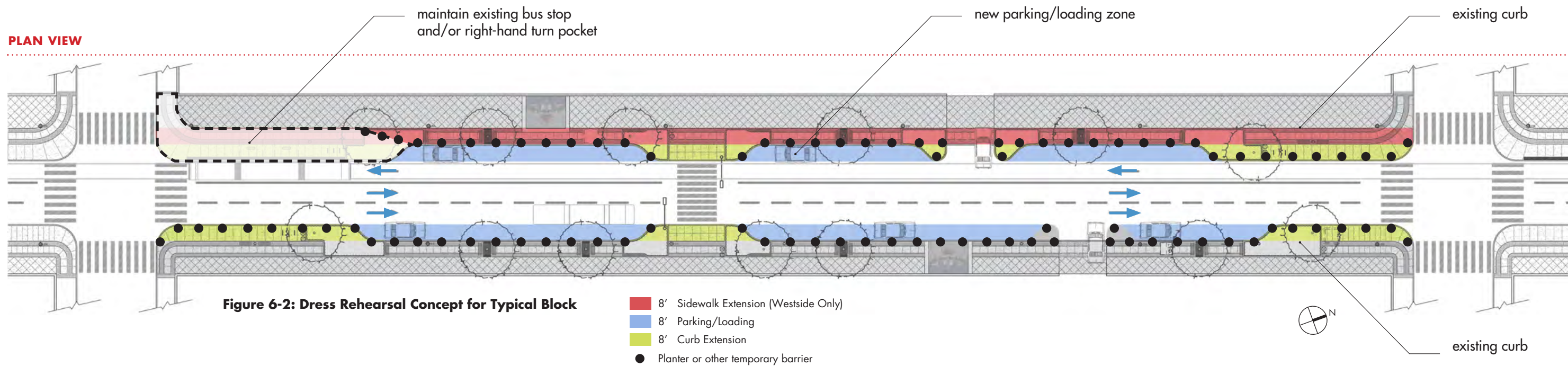

## INTERMEDIATE APPLICATIONS

### Immediate or Independent Implementation

Components of this Streetscape Master Plan that could be implemented immediately or at any time before physical construction (east and west sides of Broadway) include:

- identity banners and flags
- identity signage
- streetlighting

Regarding streetlighting, existing streetlight bases on the east side of Broadway could be retrofitted (base restored, lighting changed to LED) and infill lights (new pole and fixture) installed to maintain proper illumination levels. Since there is no change to the existing curb line on the East side, both existing and infill streetlights can be implemented. However, only existing streetlights could be changed on the West side of Broadway until the physical construction of the elements of this Plan due to the fact that the West side's planned physical configuration contains a sidewalk extension in which the new infill streetlights will be placed within the extension, staggered with the existing lights. See Chapter 4 for a detailed discussion on the streetlighting strategy.

### Temporary or Pilot "Dress Rehearsal"

Opportunities to test, or pilot, the reconfiguration of Broadway could be pursued in the interim while funding is sought and other considerations are addressed. This "dress rehearsal" could demonstrate the benefits of expanding

the public realm for pedestrians and improvement to the pedestrian and transit experience resulting from the associated traffic calming.

The space shown above in Figure 6-2 in green, the 8' curb extensions, could be claimed with, for example, painted markings or striping on the existing roadway along with planters coupled with retroreflective collapsible bollards. This would effectively colonize the space that will become the 8' sidewalk extension on the west side (shown in red), and the 8' curb extensions on both east and west sides and the resulting parking/loading zones between (shown in green and blue). So that vehicles know to park within the new 8' parking/loading zone on the west side of Broadway, planters or a "painted carpet" could designate the area for the future 8' sidewalk extension on the west side (shown in red). See Figure 6-2 for a conceptual diagram illustrating this concept.

Existing bus service, however, requires a 6" minimum curb for effective loading of passengers, and provisions for directing buses to load at and along the existing curb at existing stop locations in an interim, or pilot, application would need to be made. Figure 6-2 above shows a typical block, but many blocks of Broadway have multiple bus stops. The challenge would be to accommodate the existing bus stops that are situated at intersections, nearside and farside, as well as midblock locations, in varying patterns along the corridor if a full "dress rehearsal" is pursued along multiple blocks. Another option would be to identify one block as an initial pilot location.

These "Pop-Up Cafes" and residual roadway plazas in New York City create seating, outdoor dining, planting, and other public space amenities through the application of non-permanent materials and elements within the existing roadway.



# AP APPENDICES & REFERENCES

Appendices that offer content, materials, studies, design alternatives and other items supplementary to this Master Plan, along with relevant references and documents, can be found on the CD in the back cover of this document, or accessed through links listed below.

## APPENDICES

1. Public Meeting #1 - Broadway Walk
  - [http://bringingbackbroadway.com/timeline/ssLINK/LACITY\\_007112](http://bringingbackbroadway.com/timeline/ssLINK/LACITY_007112)
  - [http://bringingbackbroadway.com/timeline/ssLINK/LACITY\\_007113](http://bringingbackbroadway.com/timeline/ssLINK/LACITY_007113)
  - [http://bringingbackbroadway.com/timeline/ssLINK/LACITY\\_007111](http://bringingbackbroadway.com/timeline/ssLINK/LACITY_007111)
2. Public Meeting #2 - Design Alternatives
  - [http://bringingbackbroadway.com/timeline/ssLINK/LACITY\\_007065](http://bringingbackbroadway.com/timeline/ssLINK/LACITY_007065)
3. Public Meeting #3 - Preferred Design
  - [http://bringingbackbroadway.com/timeline/ssLINK/LACITYP\\_007376](http://bringingbackbroadway.com/timeline/ssLINK/LACITYP_007376)
4. Best Practices Report - Case Studies and Streetscape Elements
  - [http://bringingbackbroadway.com/timeline/ssLINK/LACITY\\_007110](http://bringingbackbroadway.com/timeline/ssLINK/LACITY_007110)
5. Cost Estimate
6. Final Traffic Study and DOT Response
7. Engineer's Survey - Design Survey for Broadway Sidewalks (April 2009)
8. Electronic Basement Scan (Broadway from 4th-6th Streets)
9. Pedestrian Paseo and Connections Plan
10. Center vs. Curb Running Streetcar Memo
11. Resources for Restoration and Fabrication of Terrazzo Paving and Basement Skylights (Glass Block)

## REFERENCES

1. Historic Architectural Survey (1998)
2. Supplemental Historic Property Survey Report (2010)
3. Streetscape Plan (Adopted 1992)
4. Building Facades Lighting Plan for the Historic Downtown Los Angeles Business Improvement District (2005)
5. Historic Downtown Los Angeles Design Guidelines (July 2002)
6. Broadway Entertainment Overlay & Design Guide (Community Design Overlay - CDO)
  - [http://bringingbackbroadway.com/timeline/ssLINK/LACITYP\\_007620](http://bringingbackbroadway.com/timeline/ssLINK/LACITYP_007620)
7. Structural Investigation of Sidewalks Along Broadway
8. Downtown Los Angeles Cordon Count (2002)

THIS PAGE LEFT INTENTIONALLY BLANK