



# Traffic Study Policies and Procedures

June 2013

City of Los Angeles  
Department of Transportation

<http://ladot.lacity.org/>



For comments or questions regarding the Traffic Study Policies and Procedures for the City of Los Angeles, please call LADOT's Development Services Division at (213) 972-8482 or (213) 972-8476.

This document may be reprinted and excerpts may be extracted without permission by LADOT. Changes to these policies may be revised or updated periodically and will be posted on the LADOT web site at:

[http://ladot.lacity.org/tf\\_Development\\_Review.htm](http://ladot.lacity.org/tf_Development_Review.htm)

June 2013

**TRAFFIC STUDY POLICIES AND PROCEDURES  
TABLE OF CONTENTS**

A. TRAFFIC STUDY REQUIREMENTS ..... 5

B. TRAFFIC STUDY PREPARATION PROCESS..... 6

C. TRAFFIC COUNT REQUIREMENTS..... 6

D. CONGESTION MANAGEMENT PROGRAM GUIDELINES..... 8

E. TRIP GENERATION CALCULATIONS ..... 8

F. PERFORMANCE MEASURES - LEVEL OF SERVICE ..... 11

G. SIGNIFICANT TRAFFIC IMPACT ..... 14

H. TRANSPORTATION MITIGATION MEASURES ..... 16

I. TRANSPORTATION DEMAND MANAGEMENT PROGRAM..... 22

J. NEIGHBORHOOD TRAFFIC MANAGEMENT PROGRAM..... 23

K. LADOT CONTACTS ..... 24

**ATTACHMENTS**

“A” Acronyms

“B” Review Process for Traffic Study

“C” Driveway Design Guidelines

“D” Standard Street Dimensions

“E” Traffic Study Memorandum of Understanding

“F” Traffic Study Figures

“G” Traffic Study Checklist

“H” Sample Traffic Count

“I” Pass-by Trips

“J” Sample LOS Calculations

“K” Sample Mitigation Drawing

“L” Transportation Demand Management and Trip Reduction Measures  
(Ordinance 168,700 / LAMC 12.26-J)

“M” Development Review Fees (Ordinance No. 180,542 / LAMC 19.15)

# INTRODUCTION

The purpose of these Traffic Study Policies and Procedures (TSPP) for the City of Los Angeles is to provide the public, private consultants and City staff with standards, guidelines, objectives and criteria to be used in the preparation of a traffic impact study. A primary objective of these policies is to ensure consistency in the preparation of traffic studies and in the planning of site access, on-site circulation, and off-site improvements for proposed land use development projects. This edition of the TSPP guides the preparation of traffic impact studies at a time when sustainability, smart growth, and the reduction of greenhouse gas emissions are prime concerns for the City - in addition to traditional mobility considerations.

A traffic study may be required of a development project due to environmental law or to City regulations, and its purpose is to predict and analyze the circulation and congestion impacts of project-generated traffic, and identify feasible mitigation measures. In this edition of the TSPP, added emphasis has been placed upon transportation demand management and multi-modal strategies, as reflected in the mitigation toolkit in Section H. This reflects the City policy trend away from automobile-centric solutions to shifting the focus on trip reduction strategies and on providing multi-modal solutions. It is strongly recommended that the applicant's traffic engineer consult with LADOT staff early in the design of the Project to ensure that traffic access and circulation issues are addressed, and to establish the scope and basic assumptions of the traffic impact study.

In order to ensure a timely review by LADOT, the following procedures and standards shall be followed in the preparation of a traffic study. It should be noted that these requirements will be updated from time to time and may differ in certain areas of the City that have specific plans or similar ordinances. You are encouraged to consult with LADOT staff before beginning a traffic study. See **Attachment A** for a list of the various acronyms used in this document.

**NOTE:** Fees for the various submittals and reviews described in this TSPP are listed in the Los Angeles Municipal Code (LAMC) Section 19.15 (Planning and Zoning Code).

## A. TRAFFIC STUDY REQUIREMENTS

Upon submission of an application for discretionary action, the City of Los Angeles Department of Transportation (LADOT) will prepare an initial assessment of the project to determine if a technical memorandum or a traffic study is required. The thresholds for determining the appropriate transportation review process is as follows:

- A **Technical Memorandum** is required when the project is likely to add 25 to 42 a.m. or p.m. peak hour trips, and the adjacent intersection(s) are presently estimated to be operating at LOS E or F. The scope for preparing a technical memorandum, which is a significantly scaled-down version of a traffic study, must be reviewed and approved by LADOT. At a minimum, the potential impacts to intersections adjacent to the project should be evaluated. The technical memorandum shall be prepared under the direction of, and signed by, a Professional Engineer, registered in the State of California to practice either Traffic or Civil Engineering.
- A **Traffic Study** is required when the project is likely to add 500 or more daily trips, or likely to add 43 or more a.m. or p.m. peak hour trips. Review of a traffic study is a nine-step process as shown in **Attachment B**. The traffic study must follow the study guidelines, as described herein, and shall be prepared under the direction of, and signed by, a Professional Engineer, registered in the State of California to practice either Traffic or Civil Engineering. Further, the Traffic Consultant must have a valid Los Angeles City Business Tax Registration Certificate.

Other requirements of a traffic study or a technical memorandum include:

- Compliance with the scoping process identified in Section B.
- Payment of any required processing fees for traffic assessment and review of a traffic study or technical memorandum.
- Submittal of the final electronic version of the traffic study or technical memorandum in portable document format (PDF) before LADOT issues their project impact assessment report.

Occasionally, LADOT will review a traffic study for a Project that is later modified or changed. If LADOT determines that the Project description has changed such that extensive and major revisions to the traffic study are required, then the revised Project shall be considered a new Project and a new traffic study and traffic review fee will be required and the environmental processing "clock" shall start again. If LADOT determines that revisions to the traffic study can be accomplished without preparing a new traffic study, then LADOT will not require a new traffic study but may require the preparation of a technical memorandum and payment of a fee specific to technical memorandums or supplemental analyses.

Similarly, if, after comments are received from LADOT on the traffic study, there is no further written communication from the applicant or the Traffic Consultant on the status of the Project for one year or more, then LADOT will assume that the Project is no longer being pursued. To reinstate the project, a new traffic study and traffic review fee will be required and the environmental processing "clock" shall start again.

## B. TRAFFIC STUDY PREPARATION PROCESS

Any applicant required to prepare a technical memorandum or traffic study for a development should follow the steps outlined below:

1. Contact LADOT to discuss the Project scope and to obtain approval on the assumptions and content of the technical memorandum or traffic study. The assumptions and content of the traffic study shall be in accordance with CEQA, the Los Angeles County CMP, any applicable Transportation Specific Plan (TSP), or other applicable laws or ordinances.
2. Provide a general description of the Project size (defined by square-footage by use and/or number of dwelling units), uses and heights of proposed new buildings and other structures to be remodeled and/or removed. Include any sequence of phased construction and any unusual conditions. Specify a building address, legal description and project title. For Projects that require the preparation of an EIR, the analysis should include project alternatives. For such projects, the LADOT assessment letter will be limited to summarizing the findings and requirements solely for the applicant's preferred project alternative or the alternative that generates the most peak period trips. Should the applicant request separate assessments for each alternative, then additional traffic study review fees may be required.
3. Submit a site plan to LADOT for preliminary discussion of the Project's driveway location(s), loading/unloading area, and parking scheme. The estimated distribution of Project trips must be according to any necessary turn prohibitions for the proposed driveways. Generally, final LADOT approval of driveway location(s) and parking scheme will be reviewed by LADOT's Citywide One-Stop Counter, or at the Valley or West Los Angeles Development Review Office (see Section K for contact information) as a clearance on the Project's building permit. In order to minimize and prevent last minute building design changes, the applicant should contact LADOT for driveway width and internal circulation requirements prior to the commencement of building or parking layout design efforts so that such traffic flow considerations are designed and incorporated early into the building and parking layout plans. The design of driveways requires approval by LADOT and the Bureau of Engineering. Please refer to the **Attachment C** for LADOT "Driveway Design" guidelines for additional information.
4. To the extent possible, projects should incorporate the use of existing alleys into the design of site access and circulation plans. The use of existing alleys should be used primarily for vehicular access, loading and service.
5. The study should reference the City's 2010 Bicycle Plan (see link below) that was adopted by the City Council on March 1, 2011. The Bicycle Plan should be reviewed to understand the goals, objectives and planned improvements. Consultation with LADOT Bicycle Program staff may be necessary to determine the implementation time frame of specific bicycle lane improvements.  
  
<http://planning.lacity.org/cwd/gnlpln/transelt/NewBikePlan/Txt/LA%20CITY%20BICYCLE%20PLAN.pdf>
6. Identify CMP intersections and other CMP requirements (see Section C).
7. Consult with other affected agencies or adjacent jurisdictions (i.e., Caltrans, L.A. County Public Works, other cities, transit agencies, etc.) to assure that all traffic-related concerns and issues that may result from the Project and may affect that agency are properly addressed in the traffic study.

8. Consult with the Bureau of Engineering and LADOT to determine any highway dedication and street improvement requirements, as well as requirements under the Americans with Disabilities Act (ADA). Please see **Attachment D** for “Standard Street Dimensions.”
9. After paying the necessary fee per LAMC Section 19.15, sign a scoping memorandum of understanding (MOU) with LADOT on the agreed upon assumptions including study intersections, residential street segments and freeway segments; related projects; trip generation rates; ambient growth rate; trip distribution pattern and trip assignments; trip credits for existing active or previous land use; vehicle trip discounts for transit, internal or pass-by trips; projected buildout year and traffic study methodology. Please see **Attachment E** for a sample MOU.
10. If the project is expected to generate a significant number of regional trips, then the traffic study may be required to incorporate subregional travel demand simulation modeling software using either TransCad or EMME/2. The decision to require travel demand modeling shall be made by the Bureau Chief supervising the development review functions of the Department. These studies will be subject to LADOT’s model calibration and validation standards.
11. The applicant shall keep LADOT informed on the progress made in completing the traffic study. LADOT approval is required on any changes to the executed MOU assumptions or any other changes made in the traffic analysis before the final report is prepared.
12. The review of a traffic study shall begin after the applicant has completed the scoping process and has paid any required fees to the City. The consultant shall also provide proof of possessing a valid Los Angeles City Business Tax Registration Certificate.
13. The traffic study should include the maps and figures identified in **Attachment F**.
14. LADOT will not release their project impact assessment report until all documents and items identified in **Attachment G** (including the entire traffic study in “pdf” format) are provided. Until then, the traffic study submittal will be deemed **incomplete**.

## C. TRAFFIC COUNT REQUIREMENTS

When collecting turning movement data at the study intersections, manual traffic volume counts should be collected in 15-minute intervals during the hours of 7:00 a.m. to 10:00 a.m. and 3:00 p.m. to 6:00 p.m., unless LADOT specifies other hours (e.g., for a signal warrant determination or weekend analysis). These traffic counts should include vehicle classifications, pedestrian volume counts, and bicycle counts. The traffic study should not use any traffic counts that are more than two years old. Additionally, unless otherwise required, all traffic counts should generally be taken when local schools or colleges are in session, on days of good weather, on Tuesdays through Thursdays during non-Summer months, and should avoid being taken on weeks with a holiday. The data should be summarized and presented in the standard LADOT format depicting turning movement volumes as shown in **Attachment H**, and submitted in digital and hard copy formats.

If traffic count data is collected utilizing video technology equipment that is left unattended in the public right-of-way, then the appropriate LADOT Development Services Division staff (see Section K) should be notified prior to the installation of such equipment. Also, the video equipment should be clearly labeled to identify it as traffic counting equipment and to include the name and contact

information of the company conducting the count (see sample label below).

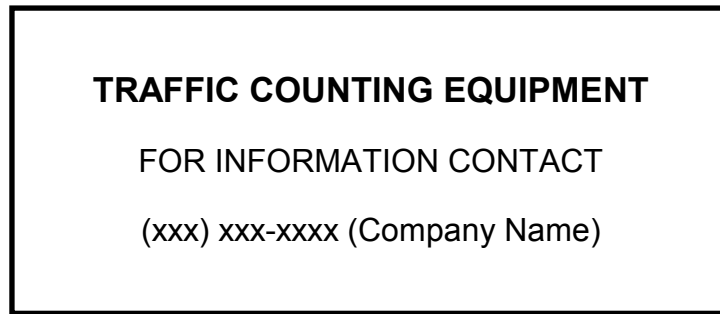

## **D. CONGESTION MANAGEMENT PROGRAM (CMP) GUIDELINES**

The "Congestion Management Program for Los Angeles County" includes guidelines intended to assist local agencies in evaluating impacts of land use projects on the CMP system through the preparation of a regional transportation impact analysis (TIA). Appendix "D" of the 2010 CMP for Los Angeles County identifies the requirements and outlines the guidelines in the preparation of the CMP transportation impact analysis. A CMP TIA is necessary for all projects required to prepare an Environmental Assessment based on local determination. The geographic area examined in the TIA must include, at a minimum, the following:

- All CMP arterial monitoring intersections, including freeway on and off-ramp intersections, where a proposed project is expected to add 50 or more trips during either the weekday a.m. or p.m. peak hours (of adjacent street traffic).
- Mainline freeway monitoring locations where a project is expected to add 150 or more trips, in either direction, during either the weekday a.m. or p.m. peak hours.

Caltrans should be consulted through the Notice of Preparation (NOP) process to identify other specific locations to be analyzed on the state highway system. To assist in the evaluation of impacts on State facilities, the project's traffic consultant should refer to Caltrans' "Guide for the Preparation of Traffic Impact Studies" found at the following web site:

[http://www.dot.ca.gov/hq/tpp/offices/ocp/igr\\_ceqa\\_files/tisguide.pdf](http://www.dot.ca.gov/hq/tpp/offices/ocp/igr_ceqa_files/tisguide.pdf)

If, based on these criteria, the TIA does not identify any impacted regional facilities, then further CMP traffic analysis is not required. However, projects must still consider transit impacts (also per the 2010 CMP) and provide a calculation of CMP "credits" and "debits" for the project. For further information on the CMP TIA process, please call LADOT CMP Monitoring Section at (213) 972-8473.

## **E. TRIP GENERATION CALCULATIONS**

Any trip credits must be approved by LADOT during the scoping process and those trips must be included in existing base year traffic counts.

1. ITE Trip Generation Rates  
The latest edition of ITE's Trip Generation Handbook for trip generation rates and formulas



should be used to estimate the Project's trip generation. However, if the Project is in a TSP area, then the procedures and trip rate identified in the TSP should be applied. If other rates are proposed, then these rates must first be submitted with appropriate background survey data for approval by LADOT.

2. Unique Developments

Unique types of development may require trip generation studies of similar facilities in order to determine actual trip rates for use in the impact analysis. These developments may include land uses for which trip generation rates are not available in the ITE Trip Generation Handbook, or land uses for which the rates in the ITE Trip Generation Handbook are based on a small sample of surveyed sites. The procedures and the results of the trip generation studies must be approved by LADOT.

3. Existing Use

When estimating the Project's net new trips, any claim for trip credits for an "existing" active land use requires that the "existing" use is/was in place at the time of the base year traffic counts. Generally, for CEQA purposes this means the "existing" use must have been active for at least 6 months during the past 2 years. To fully ensure that "existing use" trip credit claims are validated by LADOT, supporting documentation (leasing agreements, utility bills, etc.) must be submitted. Documentation of any previous environmental review of the circulation impacts of the "existing" use should be included in this submittal. Note that some specific plan ordinances allow different time frames for the determination of existing use trip credits and of any applicable trip fees.

4. Terminated Land-Use

Any claim for trip credits for a previously terminated land use must be supported with appropriate documentation of the previous active use, such as copies of any building permit, certificate of occupancy, business license, lease agreement, affidavits, or photographs as well as documentation as to when the previous land use was terminated. Documentation of any previous environmental review of the circulation impacts of the terminated land use should also be submitted in support of such claims. The absence of documentation of previous environmental review may result in denial of the claim for trip credits.

5. Pass-by Trips

Any claim for "pass-by" trip credits must use the trip reduction rates in the "LADOT Policy on Pass-By Trips" in **Attachment I**. However, these rates may be superseded by additional guidelines provided in specific plans or interim control ordinances. These rates are not applicable when reviewing impacts at Project driveways and at intersection(s) immediately adjacent to the Project site. **Pass-by trip credits shall not be used in determining the need for a traffic study.**

6. Transit Credit

LADOT encourages developers to design and construct transit-friendly projects that provide safe and walkable sidewalks to and from transit stations for project patrons. In line with the City policy to promote the use of transit and walking, LADOT, at its discretion, may allow up to a **25%** transit/walk trip credit subject to the following guidelines, on a case by case basis:

- a. Developments above or adjacent to a Metro Rail, Metrolink, or Orange Line station, or to a similar dedicated transit line station with convenient pedestrian access to the station may qualify for up to **25%** transit credit. The actual credit provided should be determined by an analysis of the transit service frequency and density at the specified transit station.

- b. Developments within a 1/4 mile walking distance of a transit station, or of a RapidBus stop, may qualify for up to a **15%** transit credit. The actual credit provided will be determined by an analysis of the transit service frequency and density at the specified transit station or RapidBus stop. To obtain the maximum credit, applicants should implement the following improvements listed in priority order:
- Provide a wider than standard sidewalk along the streets fronting the project through additional sidewalk easement or by dedicating additional right-of-way beyond street standards.
  - Improve the condition and/or aesthetics of existing sidewalks leading to transit station(s) with adequate lighting to provide for a safer pedestrian environment.
  - Provide continuous paved sidewalks / walkways with adequate lighting from all buildings in the Project to nearby transit services and stops. This may include mid-block paseos.
  - Implement transit shelter improvements/beautification.
- c. If the development is not within 1/4 mile walking distance of a transit station or a RapidBus stop, the Project may still qualify for up to **5%** transit credit. To obtain this credit, the Project should include specific features in its design that promote alternative travel modes and provide certain amenities to tenants and employees. Features and amenities that may qualify a Project for this credit include the following:
- An on-site transit information kiosk and/or on-site transit pass sales
  - On-site facilities such as ATM machines, cafeteria and convenience shopping
  - Charging for single occupant auto parking
  - Car share programs
  - Bicycle racks or other facilities on-site
  - Provision of on-site concierge service to facilitate use of transit, taxis, or private shuttles by employees/residents
  - Provision of shuttle service for employees and/or customers

No trip generation credit will be given automatically to developments located in an area with infrequent transit service. However, all reasonable efforts by the developer to promote the use of mass-transit or walking will be considered for transit credit on a case by case basis.

**NOTE:** Refer to Section H of this TSPP for transit-related mitigation measures.

7. Affordable Housing Credit

Residential or mixed-use developments that include Affordable Housing Units [as defined in LAMC 12.22-A.25 (b)] qualify for a trip reduction credit of 5% on the basis of the percentage of total dwelling units reserved as affordable. A development for which all proposed dwelling units are to be affordable would receive the maximum aggregate credit of 5% ( $100 \times 0.05$ ). A development with 20% affordable units would qualify for a 1% aggregate trip credit ( $20 \times 0.05$ ), etc. Affordable Housing credit is allowed in addition to any Transit Credit granted through Section D.6 above.

## F. PERFORMANCE MEASURES - LEVEL OF SERVICE

1. For land use development projects, the Transportation Research Board, Circular 212 Critical Movement Analysis (CMA) Planning Method, should be used to analyze traffic operating conditions at study intersection(s). CMA is a method that determines the volume to capacity (V/C) ratio on a critical lane basis and Level of Service (LOS) associated with each V/C ratio at a signalized intersection. V/C ratios are measured on a scale of 0 to 1.000. LOS describes the quality of traffic flow and is a measure of such factors as travel speed, travel time and flow interruptions. LOS range from "A" to "F" with LOS "A" representing excellent, free flow conditions and LOS "F" representing jammed, forced flow conditions. The following table (see page 12) provides a description of the different LOS's and associated V/C ratios.
2. LADOT has developed a CMA spreadsheet in MS-Excel format to estimate the LOS for study intersections. All traffic studies that require the use of CMA to estimate impacts should be prepared using this spreadsheet. A digital copy of the spreadsheet will be provided to firms preparing traffic studies in the City of Los Angeles. Please contact any of the LADOT sections identified in Section K for a copy of the LOS spreadsheet. Completed LOS calculations must be submitted to LADOT in digital format and included with the submittal of the traffic study. A typical sample of a LOS calculation worksheet is shown in **Attachment J**. For some intersections (such as a 5-legged intersection, diamond interchange, etc.), the V/C ratio may need to be calculated manually or may need to be adjusted accordingly. The appropriate methodology for these special cases should be discussed with the appropriate LADOT staff during the MOU scoping process.
3. The use of the Highway Capacity Manual's (HCM) delay-based methodology for signalized intersections is acceptable to LADOT for traffic impact studies associated with infrastructure projects, including transit, rail, bicycle and roadway improvements. In such cases, micro-simulation may also be necessary to fully understand the effects of the project in terms of queue lengths, traffic signal timing parameters, transit travel times, etc. The following table (see page 12) provides a description of the different LOS's and associated delays measured in terms of "delay per vehicle."
4. The intersection capacity at intersections along a congested corridor may need to be adjusted to account for reduced capacity due to gridlock, heavy pedestrian volumes, or other prevailing factors. The LOS spreadsheet developed by LADOT allows users to override the standard CMA capacities to account for these factors. However, any such revisions to the standard capacities or to any formula or function used in the LOS spreadsheet require LADOT approval.
5. Since the CMA and HCM methodologies and the resulting LOS is primarily an automobile-oriented measure, LADOT is evaluating other performance measures that can yield information related to other modes of travel. Doing so can provide useful information regarding the ability of a project or traffic mitigation measure to reduce vehicle-miles-traveled (VMT), to reduce green-house gas (GHG) emissions, and to promote other modes of travel. Although some traffic mitigation measures can provide a measurable reduction in VMT or GHG emissions, these measures may not show a quantifiable benefit when the performance measure is LOS. In these cases, the traffic study should include a description of the proposed improvement and the anticipated benefits to air quality. The traffic volume counts collected at the study intersections should also identify the volumes of pedestrians and bicycles that enter the intersection. These are helpful parameters and provide the necessary context when evaluating the overall operation of each intersection.

### LEVEL OF SERVICE DEFINITIONS FOR SIGNALIZED INTERSECTIONS <sup>1</sup>

Level of Service	Volume/Capacity Ratio	Delay per Vehicle (sec / veh)	Definition
A	0.000 - 0.600	≤ 10	EXCELLENT. No vehicle waits longer than one red light and no approach phase is fully used.
B	0.601 - 0.700	> 10 - 20	VERY GOOD. An occasional approach phase is fully utilized; many drivers begin to feel somewhat restricted within groups of vehicles.
C	0.701 - 0.800	> 20 - 35	GOOD. Occasionally, drivers may have to wait through more than one red light; backups may develop behind turning vehicles.
D	0.801 - 0.900	> 35 – 55	FAIR. Delays may be substantial during portions of the rush hours, but enough lower volume periods occur to permit clearing of developing
E	0.901 - 1.000	> 55 – 80	POOR. Represents the most vehicles that intersection approaches can accommodate; may be long lines of waiting vehicles through several signal cycles.
F	Greater than 1.000	> 80	FAILURE. Backups from nearby intersections or on cross streets may restrict or prevent movement of vehicles out of the intersection approaches. Tremendous delays with continuously increasing queue lengths.

<sup>1</sup> Sources: Transportation Research Board, Interim Materials on Highway Capacity, Transportation Research Circular No. 212, January 1980; and Transportation Research Board, Highway Capacity Manual 2010.

5. V/C ratios should be calculated to three decimals, rounded and summarized in a table showing weekday a.m. and p.m. peak hour LOS at study intersections for existing conditions, existing with Project, future without Project, future with Project and future with Project plus mitigation. In a separate appendix, the traffic study shall include the detailed LOS worksheets for each study intersection. The table summarizing the results of the impact analysis should follow the format below:

<i>(Year)</i> Existing Traffic Conditions	Existing Plus Project	Project Impact	<i>(Buildout Year)</i> Cumulative Base <sup>2</sup>	<i>(Buildout Year)</i> Project <sup>3</sup>	Project Impact	<i>(Buildout Year)</i> Project with Traffic Mitigation	Net Project Impact
V/C LOS	V/C LOS		V/C LOS	V/C LOS		V/C LOS	

6. The LADOT traffic count database should be searched for any recent traffic counts at the study intersections. If recent LADOT traffic counts are not available, then new traffic counts shall be collected by a qualified data collection firm. Unless there are special circumstances, traffic volume counts that are more than two years old will not be accepted and new traffic counts should be collected.
7. The traffic study should include a map or table that illustrates the lane configurations and lane volumes for each study intersection. Also, any programmed and funded transportation improvements that are expected to be implemented on or before the project buildout year should be identified in the traffic study. Should these programmed improvements include a modification to the existing lane configuration to any of the study intersections, then the study should identify these changes and include the revised lane configuration in the V/C calculations for all future scenarios.
8. In determining the lane assignments for an intersection with an unmarked curb lane, the V/C/ calculations may assume the capacity of a functional right-turn only lane, provided that the lane width is a minimum of 18 feet wide, there are no bus stops at the approach, on-street parking would not impede vehicles turning right, the pedestrian volumes are low during the peak hour, and this de-facto right-turn operation has been verified in the field.
9. If necessary, the scope of the traffic impact analysis should be expanded to evaluate special circumstances, such as:
  - Summer weekend activity in recreational areas
  - University/school graduation ceremonies or events
  - Holidays or special events
  - Swing shifts
  - Developments with special visitor, employee or shopping hours or days
  - Alternative Project scenarios if required by another City Department or adjacent jurisdiction
  - Analysis of Freeway LOS

<sup>2</sup> The “cumulative base” scenario represents existing traffic conditions plus increases in traffic related to ambient growth and related projects

<sup>3</sup> The “project” scenario is the cumulative base scenario plus the Project trips

10. Should the traffic study include an analysis of freeway segments, then consultation with Caltrans is needed on the capacity analysis methodology used to evaluate state facilities.
11. When determining which intersections should be included in the impact analysis for development projects, only signalized intersections should be selected. Unsignalized intersections should be evaluated solely to determine the need for the installation of a traffic signal or other traffic control device, but will not be included in the impact analysis. When choosing which unsignalized intersections will be reviewed, intersections that are adjacent to the project or that are expected to be integral to the project's site access and circulation plan should be identified. For these intersections, the overall intersection delay should be measured pursuant to procedures accepted by LADOT during the scoping process. If, based on the estimated delay, the resultant LOS is E or F in the "future with Project" scenario, then the intersection should be evaluated for the potential installation of a new traffic signal. The study shall include a traffic signal warrant analysis prepared pursuant to Section 353 of LADOT's Manual of Policies and Procedures and submitted to LADOT for review and approval.

**G. SIGNIFICANT TRANSPORTATION IMPACT**

1. A transportation impact at a signalized intersection shall be deemed "significant" in accordance with the following table except as otherwise specified in a TSP, ICO or CMP:

SIGNIFICANT TRANSPORTATION IMPACT ( <i>V/C Methodology</i> )		
Level of Service	Final V/C Ratio	Project-Related Increase In V/C
C	> 0.701 - 0.800	equal to or greater than 0.040
D	> 0.801 - 0.900	equal to or greater than 0.020
E	> 0.901-1.000	equal to or greater than 0.010
F	Greater than 1.000	equal to or greater than 0.010

For purposes of this calculation, the "Final V/C Ratio" shall mean the future V/C ratio at an intersection considering impacts with project, ambient and related Project growth but without proposed traffic mitigation. "Project-Related Increase in V/C" shall mean the change in V/C between the future V/C ratio with Project, ambient and related project growth but without proposed traffic mitigation and the future V/C ratio with ambient and related project growth but without Project and proposed traffic mitigation.

2. When utilizing the HCM methodology for signalized intersections for transportation infrastructure projects, a transportation impact shall be deemed "significant" in accordance with the following table:

SIGNIFICANT TRANSPORTATION IMPACT ( <i>Delay Methodology</i> )		
Level of Service	Final Delay	Project-Related Increase In Delay
C	> 20 - 35	equal to or greater than 6.0 seconds
D	> 35 – 55	equal to or greater than 4.0 seconds
E	> 55 – 80	equal to or greater than 2.5 seconds
F	> 80	equal to or greater than 2.5 seconds

For purposes of this calculation, the "Final Delay" shall mean the future delay per vehicle at an intersection considering impacts with project, ambient and related Project growth but without proposed traffic mitigation. "Project-Related Increase in Delay" shall mean the change in delay between the future delay with Project, ambient and related project growth but without proposed traffic mitigation and the future delay with ambient and related project growth but without Project and proposed traffic mitigation.

3. Commercial projects may be required to conduct residential street impact analysis. A local residential street can be potentially impacted based on an increase in the average daily traffic volumes. The objective of the residential street analysis is to determine the potential for cut-through traffic impacts on a residential street that can result from a Project. Cut-through trips are measured as vehicles that bypass a congested arterial or intersection by instead opting to travel along a residential street. To address these potential impacts, non-restrictive traffic calming measures should be considered and, if deemed warranted, implemented to off-set any anticipated impacts. Restrictive traffic calming measures should not be considered. See Section J for a description of restrictive and non-restrictive traffic calming measures. When selecting residential street segments for analysis during the traffic study scoping process, all of the following conditions must be present:

- the proposed project is a non-residential development and not a school
- the arterial is sufficiently congested, such that motorists traveling on the arterial may opt to divert to a parallel route through a residential street; the congestion level of the arterial can be determined based on the estimated LOS under project conditions of the study intersection(s); LOS E and F are considered to represent congested conditions
- the Project is projected to add a significant amount of traffic to the congested arterial that can potentially shift to an alternative route; Project traffic would need to exceed the daily minimum significance thresholds listed below under "Project-Related Increase in ADT"
- the local residential street(s) provides motorists with a viable alternative route

A local residential street shall be deemed significantly impacted based on an increase in the projected average daily traffic (ADT) volumes as follows:

<b>Projected ADT with Project (Final ADT)</b>	<b>Project-Related Increase In ADT</b>
0 to 999	120 or more
1,000 to 1,999	12 percent or more of final ADT
2,000 or 2,999	10 percent or more of final ADT
3,000 or more	8 percent or more of final ADT

## H. TRANSPORTATION MITIGATION MEASURES

When a Project is expected to result in significant traffic impacts, the Project’s traffic consultant should meet with LADOT to discuss potential transportation mitigation options before submitting a traffic study. Different transportation mitigation solutions should be explored when attempting to mitigate a Project’s significant traffic impact to a level of insignificance. However, since sustainability, smart growth and the reduction of greenhouse gas emissions have become prime concerns for the City in addition to traditional traffic flow considerations, mitigation programs should be developed to first focus on minimizing the demand for trips by single-occupant vehicles through trip reduction strategies or by encouraging other modes of travel like public transit and bicycling. Therefore, the following mitigation categories, listed in priority order, should be considered when evaluating and proposing transportation mitigations:

1. Transportation Demand Management Program (See Section I)  
 All projects are required to comply with LAMC 12.26-J. For additional trip reduction credits as traffic mitigation, suggested elements of a TDM program should include, but not be limited to, the following elements:
  - a. Implementation of vehicle trip reduction incentives and services for Project employees and/or tenants; provide on-site education on alternative transportation modes.
  - b. Implementation of flexible / alternative work schedules and telecommuting programs.
  - c. Provide a bicycle and pedestrian-friendly environment; provide bicycle amenities such as secure bicycle racks, lockers and showers for employees.
  - d. Provide bicycle parking beyond the requirements of the Bicycle Parking Ordinance No. 182,386.
  - e. Financial contribution to the City’s Bicycle Plan Trust Fund.
  - f. Implement a Bicycle Friendly Street improvement as identified in the Bicycle Plan; such improvements can include curb extensions, wayfinding signage, diverters, bicycle loop detection, shared lane markings, etc.
  - g. Conduct educational workshops for Project employees and/or tenants related to the usage of bicycles on streets including how to integrate bicycles use with



transit use and how to ride next to vehicles.

- h. Provide bicycle repair stations for use by Project employees and/or tenants.
- i. Provide fully or significantly subsidized transit passes to Project residents and/or employees.
- j. Implementation of first and last mile solutions that can increase the use of transit by bridging the gap between transit stops/stations and a commuter's origin or final destination
- k. Implementation of a parking cash-out program.
- l. Pursuant to Internal Revenue Code Section 132(f), arrange pre-tax dollar transit commute expense accounts to provide transportation fringe benefits to eligible employees.
- m. Vehicle trip reduction incentives and services affecting visitors to the project, such as shoppers, clients, patrons, etc.
- n. Financial support for the capital and/or operating costs of enhanced transit or vanpool service to the project.
- o. Provision of a variety (mixed use) of land uses in close proximity, facilitating trip making by walking, cycling or local shuttles.
- p. Provision of on-site facilities that encourage the use of alternate forms of transportation such as bicycle lanes and amenities, enhanced pedestrian connections, telecommuting facilities, etc.
- q. Include site trip cap and/or parking cap in trip monitoring agreements.

An initial draft performance-based TDM Program, prepared as outlined in Section I, must be included in the traffic study for any Project seeking TDM trip reduction credits. If the TDM Program is acceptable to LADOT, the applicant will be allowed to reduce the total Project trips by an amount determined to be commensurate with the measures proposed in the TDM Program.

2. Transit Capacity and Access Improvements

The elements listed below should be considered when developing transit system strategies. The exact mitigation value shall be determined on the basis of the development's size, type of use(s), and the frequency / density of transit service in the vicinity of the Project.

- a. Contribution of funds or equipment to increase the capacity of existing transit systems (must be coordinated with transit providers)
- b. Transit shuttles provided by applicant (e.g., bus, taxicab, van, etc.)
- c. Contributions toward construction or enhancement of transit stations or centers
- d. Provision of facilities or equipment which expedite transit flow (e.g., transit priority signal systems, HOV lanes, etc.)

- e. Contributions toward operation/maintenance costs and/or fleet vehicle replacement costs of existing transit service (must be coordinated with providers)
3. Parking Management Measures
    - a. Contribution of equipment or funds to implement intelligent parking systems, which can include the use of new parking meter technology, vehicle sensors, dynamic signage, a central management system and a real time parking guidance system. Such upgrades should be implemented along appropriate City block faces with existing parking meter zones in the vicinity of the development, or at all approaches and departures of an impacted intersection.
    - b. “Unbundling” of parking spaces in multiple unit residential development, e.g., parking shall be bought or rented separately when the dwelling units are initially bought or rented, enabling discounts for not using parking spaces and/or complementing Flex Car or other car sharing programs.
    - c. “Unbundling” of parking spaces in non-residential development, e.g., employee parking is not to be provided free-of-charge and/or parking costs are listed as a separate line item in lease agreements. This would be a necessary component of a Parking Cash-Out program.
  4. Jobs / Housing Balance Measures

A trip reduction mitigation value of up to 10% may be approved for a development that incorporates Work Force housing (dwelling units affordable to, and reserved for, sale to Low and Moderate Income persons/families as defined in CA Health and Safety Code Section 50093 who are employed at the development) or which constructs such housing within a one-half mile of the development. The exact mitigation value shall be determined based upon an analysis of the development size and type of land use, employment type/density, and the number of Work Force housing units to be provided. The affordability of the Work Force housing units must be guaranteed for a minimum period of thirty (30) years.
  5. Traffic Signal Operational Improvements

Traffic signal enhancements that include, but are not limited to, traffic signal phasing modifications, new signal installations, signal controller upgrades, CCTV camera installations, additional vehicle detector loops, etc., may be considered and provided as traffic mitigation or as supplemental measures to proposed intersection mitigations. Signal improvements that are considered project-serving or that provide access to the project are not considered traffic mitigations.
  6. Street Widening and Other Physical Improvements

Recommended improvements must be demonstrated to be physically feasible and must meet minimum City standards. If a physical mitigation measure is proposed on a future “bicycle lane” street (see “Designated Bikeways” in Appendix D of the Bicycle Plan), then the mitigation should be designed to accommodate the future bicycle lane. Please see **Attachment K** for a sample intersection mitigation drawing. Particular attention shall be paid to resultant sidewalk widths, which should remain adequate for pedestrian activities and meet ADA requirements.
  7. Street Re-striping and Parking Prohibitions

Generally, street re-striping is not a preferred mitigation measure because it often requires parking prohibitions which may cause secondary impacts in certain commercial and

- residential areas. Therefore, any parking impacts should be clearly identified through a parking inventory and demand analysis. This analysis should include proposed measures to mitigate any such impacts to the extent feasible. Additionally, should the mitigation require the permanent removal of a parking meter space, payment to LADOT for lost parking meter revenues is required. The current average annual revenue generated by one parking meter is \$1,000. Therefore, based on this average, the removal of each metered, on-street parking space will require payment to LADOT in the amount of the average annual revenue over a ten year period (currently estimated at \$10,000 per space).
8. Fair Share Contributions  
If a traffic study demonstrates that the applicant is responsible for only a portion of a large and costly transportation enhancement, such as a bridge or roadway widening project, a fair share contribution toward the cost of the improvement may be an acceptable mitigation. Fair share contributions are applicable in those cases where there are other proposed developments in the vicinity that may also contribute toward the cost of the improvement.
  9. TSP Mitigation Trust Fund  
If project is located in a TSP area, an applicant may be required to pay "trip fees" into a mitigation trust fund for implementation of larger regional projects that are specified in the TSP.
  10. Infeasible Mitigation Measures  
The traffic study should also include a discussion of mitigation measures deemed to be infeasible, as appropriate, to record the reason(s) for rejecting these measures.
  11. Substitute Mitigations  
When no feasible mitigation measure is available, LADOT at its discretion may accept a substitute mitigation measure at an adjacent intersection provided that appropriate technical analysis is prepared to show the benefit at the impacted intersection.
  12. Unmitigated Impacts  
For projects with unmitigated traffic impacts that seek a Statement of Overriding Considerations, other suitable enhancements should be evaluated and considered that would address quality-of-life issues like implementing non-restrictive traffic calming measures, traffic safety enhancements, traffic signal timing upgrades, and community streetscape features like lighting, landscaping, shade, sidewalk repairs, etc. Such improvements, whether voluntary or required, that benefit the community can serve to off-set the significant impacts of a project. Also, when no other mitigation measures are available and the Project results in unmitigated impacts, the developer should consider revising and reducing the scope of the project.

The adequacy and feasibility of each mitigation measure must be determined to the satisfaction of LADOT. The final required mitigation measures for the project will be determined by the appropriate decision maker (e.g., the City Planning Commission, the City Council). All mitigation measures shall comply with the following requirements:

1. Plan Preparation for Physical Mitigation
  - a. Existing Conditions
    - i. Prepare preliminary geometric design drawing to a scale 1" = 40' for each of the significantly impacted intersections for existing conditions, where

restriping and/or street widening is a proposed mitigation measure. Make field investigations and show all important roadway details, including adjacent land use(s), parking restrictions, sidewalks, driveways, lane dimensions, roadway striping, curb and right-of-way lines, and "footprints" of building line.

- ii. Use existing LADOT drawings where available and field check for accuracy to reflect current conditions.
- iii. Provide copy of current City Bureau of Engineering District Map illustrating public rights-of-way on impacted streets.

b. Future Conditions with Mitigation

- i. Prepare preliminary geometric design drawing to a scale of 1" = 40' showing recommended changes in striping including additional roadway and right-of-way necessary to mitigate the significant impact(s) of the project for each location where street restriping and/or street widening is a proposed mitigation measure.
- ii. Plans showing striping modifications should include adequate segments of the roadway (approximately 300-400 feet on each leg of the intersection) to indicate the appropriate transitions from the existing striping.

c. Standards

Geometric plans shall be prepared on LADOT 24" × 36" standard sheets. If more than one mitigation is possible at a given location, separate plans for each alternate mitigation measure may be prepared in consultation with LADOT. Mitigation design drawings that are processed through the B-permit process should be submitted to the LADOT Design Division in Auto-Cad format. The following criteria and standards should be used in preparation of plans:

- i. Drawings of street improvements must show existing and proposed dimensions for:
  - Roadway widths
  - Right-of-way widths
  - Sidewalk widths
  - Curb radii
  - Location of traffic islands
  - Individual lane widths
  - Striping "tapers" and "cat-tracks"
- ii. Items to be shown on plans:
  - Parking restrictions (existing and proposed), bus stops (existing and relocated), driveways, signals, street lights, signs, trees, utility poles and catchment basins.
  - Type of development of adjacent properties.
- iii. Drawings of street improvements must show existing and proposed dimensions (typical dimensions are shown below). Increased widths may be

required for special circumstances such as predominant use by trucks and buses, higher design speeds, higher pedestrian volumes, etc.

- Through lane = 10' - 11'
- Left turn lane or two-way left-turn median = 10' - 11'
- Right turn lane = 12'
- Lane adjacent to curbed median = 12'
- Curb lane without parking = 12' - 13'
- Curb lane with parking = 18' (low speed) to 20' (high speed)
- Bike lane without parking = 5' - 6'
- Bike lane with parking = 13'

**Note that modified street standards have been adopted for Downtown Los Angeles and the Hollywood Community Plan area which differ from the City's Standard Plan of Street Dimensions.**

- d. Submit 3 copies of any proposed mitigation plans with the traffic study to the appropriate LADOT Planning Office for review and comment by LADOT's Planning Office, District Office, and Design Division.
  - e. Attach the a.m. and p.m. peak hour lane volume diagram with the geometric design plan for each intersection.
  - f. Revise mitigation plans as required and re-submit the final mitigation plans to LADOT for approval.
2. Guarantees of Mitigation Measures  
All physical transportation mitigations and associated traffic signal work within the City must be guaranteed through the B-Permit process of the Bureau of Engineering, prior to the issuance of any building permit and completed prior to the issuance of any certificate of occupancy. Temporary certificates of occupancy may be granted in the event of any delay through no fault of the applicant, provided that, in each case, the applicant has demonstrated reasonable efforts and due diligence to the satisfaction of LADOT. All improvements along state highways and freeway ramps require approval from Caltrans. An encroachment permit must be obtained from Caltrans for these improvements before the issuance of any building permits.

In the event the originally proposed mitigation measure becomes infeasible, a substitute mitigation measure may be provided subject to approval by LADOT or other governing agency with jurisdiction over the mitigation location, upon demonstration that the substitute measure is equivalent or superior to the original measure in mitigating the project's significant impact.

3. Mitigation Monitoring Program in Draft EIR's  
The necessary components of each mitigation measure in a mitigation monitoring program should be stated separately for inclusion in the Draft EIR. These include:
  - a. Identification of the responsible agency for monitoring the measure and the designated coordination for all participants
  - b. Qualifications, if any, of the necessary monitor(s)

- c. The proposed schedule of the mitigation monitoring (i.e., dates of start-up, observation period, frequency, and completion/termination) - this should be stated for physical mitigation measures required during construction as well as those that are for the operation/life of the project (e.g., TDM program)
- d. Sampling techniques and testing procedures to be used
- e. Equipment and materials needed
- f. Funding required and sources of funding for monitoring activities by both project and City personnel (especially for long-term monitoring activities)

If the City adopts a Citywide Mitigation Monitoring Program, the components of the mitigation monitoring plan will be modified accordingly.

## I. TRANSPORTATION DEMAND MANAGEMENT (TDM) PROGRAM

TDM is a program designed to facilitate the use of alternate transportation modes to decrease dependency on single occupancy vehicles. LADOT strongly encourages the development of a comprehensive TDM program to eliminate as many new project trips as possible. LAMC 12.26-J (which applies only to construction of new, non-residential development in excess of 25,000 square feet gross floor area) requires, prior to issuance of a building permit, that the owner or applicant agree, by way of a covenant that runs with the land, to provide and maintain minimal TDM measures. LAMC 12.26-J is summarized in **Attachment L**.

LAMC 12.26-J notwithstanding, a consultant may be required to prepare a more comprehensive, integrated program of TDM measures. If TDM, Transit, and/or Parking Management strategies are claimed as a mitigation of project-related traffic impacts, or if required under any applicable TSP or other City ordinances, then the TDM program shall include the following elements:

- Statement of measurable goals to be achieved
- Estimate of trips to be reduced
- Key elements of the program
- Schedule and responsibilities for implementation
- Identification of funding responsibilities
- Method of monitoring program performance
- Contingency plan and/or penalties for failure to achieve goals

If vehicle trips will be reduced by operating or contributing to the operation of transit systems, a description of the transit program as well as a letter of support from the related transit service provider is required. The transit program shall contain elements similar to the TDM program described above. If the project is a mixed-use project that includes housing, LADOT will consider reducing the project's trip generation to account for the internal trip characteristics of the project. This credit will be limited to the trips that would be affected by the special features of the project relative to ITE or TSP trip generation rates. If the project site is under one ownership or control; is uniquely located so as to permit accurate monitoring of all site trips; and extraordinary trip reduction goals are proposed, LADOT may recommend a trip cap agreement. Such an agreement typically places a cap on the total vehicle trips entering and leaving the site during peak hours and includes a monitoring and contingency plan.

## **J. RESIDENTIAL NEIGHBORHOOD TRAFFIC MANAGEMENT PROGRAM**

If the traffic study indicates that the project may potentially result in residential street impacts, then a plan to reduce project traffic from traveling through nearby residential areas may be required as part of the mitigation program for the project. If neighborhood traffic management (NTM) measures are required to off-set potential residential street impacts, then, prior to project occupancy, the applicant shall conduct public outreach and develop a NTM plan, in consultation with LADOT, the affected Council District office and the affected neighborhood. Coordination with the appropriate Council District office may be necessary to designate the stakeholders that should facilitate the public outreach. The applicant shall also be responsible for conducting the engineering evaluation of the potential measures to determine the feasibility in regards to drainage, constructability, street design, etc. The applicant shall also be responsible in implementing any NTM measures approved by LADOT and supported by stakeholders. Prior to the outreach, a cost estimate on the potential NTM plan shall be determined in consultation with LADOT. The cost should be commensurate with the size of the project and with the level of residential street impacts that are expected. The development of the plan shall include the analysis of any relevant traffic data, roadway characteristics and conditions of the impacted residential street segments identified in the study.

The NTM plan should focus solely on implementing non-restrictive traffic calming, which may include, but are not limited to, traffic circles, speed humps, roadway narrowing effects (raised medians, traffic chokers, etc.), landscaping features, roadway striping changes, and stop sign pattern. Restrictive measures such as turn restrictions, physical barriers, signal metering, etc., should not be considered since these measures can potentially lead to the diversion of traffic from one street to another, or one neighborhood to another. The NTM plan should also consider and evaluate neighborhood improvements that can offset the effects of added traffic, including street trees, sidewalks, landscaping, neighborhood identification features, and pedestrian amenities. Such measures can support trip reduction efforts by encouraging walking, bicycling, and the use of public transit. As with other mitigation measures, any required NTM measures on City streets must be implemented prior to the issuance of any certificates of occupancy. A temporary certificate of occupancy may be granted in the event of any delay through no fault of the applicant, provided that the applicant has demonstrated reasonable efforts and due diligence to the satisfaction of LADOT. The NTM plan shall be prepared in conformance with the guidelines established by LADOT and should contain, at a minimum, the following elements:

- Description of existing facilities and neighborhood traffic conditions
- Description of proposed neighborhood traffic controls, including sketches of specific street modifications
- Analysis of any change in existing or future traffic patterns as a result of implementation of the plan
- Implementation and monitoring program

## K. LADOT CONTACTS

Thank you for your cooperation. If you have any questions, please call the appropriate LADOT Development Services Division office as follows:

- Metro Development Review  
100 S. Main Street, 9<sup>th</sup> Floor  
Los Angeles, CA 90012  
(213) 972-8482 or (213) 972-8481  
Fax (213) 972-8418  
*Coverage area includes all areas south of Mulholland Drive, east of Robertson Boulevard and north of the San Pedro Community Plan area.*
- West Los Angeles Development Review  
7166 W. Manchester Avenue  
Los Angeles, CA 90045  
(213) 485-1062  
Fax (213) 485-1285  
*Coverage area includes San Pedro and all areas south of Mulholland Drive and west of Robertson Boulevard*
- Valley Development Review  
6262 Van Nuys Boulevard, 3<sup>rd</sup> Floor  
Van Nuys, CA 91401  
(818) 374-4699  
FAX (818) 374-4696  
*Coverage area includes the entire San Fernando Valley north of Mulholland Drive*
- LADOT City-wide One-Stop Counter  
201 N. Figueroa Street, 4<sup>th</sup> Floor  
Los Angeles, CA 90012  
(213) 482-7024



## **ATTACHMENT A**

### **ACRONYMS**

ADA	Americans with Disabilities Act
ADT	Average Daily Traffic
AQMD	Air Quality Management District (SCAQMD)
ATCS	Adaptive Traffic Control System
ATSAC	Automated Traffic Surveillance and Control
AVR	Average Vehicle Ridership
BOE	Bureau of Engineering
CALTRANS	California Department of Transportation
CEQA	California Environmental Quality Act
CMA	Critical Movement Analysis
CMP	Congestion Management Program
CRA	Community Redevelopment Agency
DCP	Department of City Planning
DEIR	Draft Environmental Impact Report
EIR	Environmental Impact Report
ICO	Interim Control Ordinance
ITE	Institute of Transportation Engineers
LADOT	Los Angeles Department of Transportation
LACMTA	Los Angeles County Metropolitan Transportation Authority
LAMC	Los Angeles Municipal Code
LOS	Level of Service
MOU	Memorandum of Understanding
NOP	Notice of Preparation
NTM	Neighborhood Traffic Management
SCAG	Southern California Association of Governments
TDM	Transportation Demand Management
TIA	Traffic Impact Analysis
TSM	Traffic System Management
TSP	Transportation Specific Plan
VMT	Vehicle Miles Traveled
V/C	Volume to Capacity Ratio

**ATTACHMENT B**

**LADOT REVIEW PROCESS FOR TRAFFIC STUDY**

STEP

1

Preliminary discussion with Consultant/Developer  
on project description including site plan

2

Scoping of Traffic Study  
with the consultant

3

Consultant and LADOT execute an MOU  
(fees may apply per LAMC 19.15)

4

Consultant/Developer pays review  
fee and submits Traffic Study

5

LADOT prepares initial comments  
on the traffic study, if necessary

6

Consultant submits corrections/revisions to the  
traffic study, if necessary

7

LADOT prepares initial comments on proposed mitigation  
measures, if necessary

8

Consultant submits corrections/revisions on proposed mitigation  
measures, if necessary, and electronic copy of traffic study

9

LADOT issues an assessment letter

 Department of Transportation	<b>MANUAL OF POLICIES AND PROCEDURES</b>	SECTION NO. 321	
	<b>SUBJECT</b>  <b>ATTACHMENT C</b>  DRIVEWAY DESIGN	DATE 2/2003	
		DIST.	ORIGINATOR 10
		PAGE 1 of 13	

I. Purpose

This Section provides the basic criteria for review of driveway designs.

The Department of Transportation (DOT) has a broad responsibility to ensure the safe and efficient use of City streets. The impact on streets is influenced by the design and use of off-street parking and loading facilities to accept and discharge vehicles. The goal of good driveway design is to minimize adverse effects on street traffic.

II. Conditions of Tracts or Other Actions

DOT requirements of driveways, prohibitions of driveways on certain streets, limitations of turning movements, and other conditions are often imposed through:

- A. Zone Changes: These requirements usually originate in DOT during the zoning review process and are adopted by the Council.
- B. Conditional Uses: Hearing examiners obtain the recommendations of DOT and often include traffic requirements.
- C. Tract Review: All Tract maps are subject to approval by the Advisory Agency (i.e., a deputy of the Director of Planning). The Advisory Agency is assisted by the Subdivision Committee, on which DOT is represented. The Advisory Agency frequently includes traffic requirements in its final determination.

It is necessary in many cases to “clear” these traffic requirements, i.e., certify that they have been carried out. This is done by DOT’s representative on the Subdivision Committee, who must approve any plans affected by such requirements.

III. Code Requirements

The Los Angeles Municipal Code (LAMC) specifically requires DOT to carry out certain functions with relation to off-street parking facilities. The Bureau of Transportation Programs and Development Review of the Department serves as a review agency for driveways and other off-street uses through the required approval of Building Permit Applications. Relevant Municipal Code Sections are:

- 12.21 A-4(g)
- 12.21 A-5(e)
- 12.21 A-5(i)
- 12.21 A-5(j)
- 12.21 C-6(a)

PAGE 2	DATE 02/2003	SECTION 321	SUBJECT DRIVEWAY DESIGN	Department of Transportation MANUAL OF POLICIES & PROCEDURES
-----------	-----------------	----------------	----------------------------	---

See Appendix C for further information.

#### IV. Definitions

For purposes of this Section, certain terms and words are defined as follows:

A. Arterial Highway - A street that either:

1. Accommodates 10,000 or more vpd (vehicle trips per typical weekday), or
2. Is designated as a Major or Secondary Highway on the City's Highways and Freeways Plan.

B. Collector Street - A street that either:

1. Accommodates more than 1500 but less than 10,000 vpd, or
2. Is a designated Collector Street on the applicable Community Plan.

#### V. Driveway Location Planning

The basic principle of driveway location planning is to minimize possible conflicts between users of the parking facility and users of the abutting street system. The public interest requires optimum capacity of streets and highways to carry traffic with minimum potential for traffic accidents. The safety of pedestrians is also considered.

This calls for the minimum number of driveways, consistent with street and lot capacity, located on streets with the least traffic volume, when there is a choice. Driveways should provide high-entry capacity from the abutting street. To determine if a facility will meet the desired criteria, it is necessary to check location of driveways, size of driveways, number of driveways, operation and design of entrances and exits, and internal circulation.

A. Number of Driveways Along Arterial Frontage

Driveways should not be permitted along arterial highways where the proposed development is:

1. Residential, and access is possible using an alley or non-arterial street, or
2. Industrial or commercial, and
  - a. At the intersection of the arterial highway with a non-arterial street, and
  - b. Access is possible along the non-arterial frontage.

Otherwise the maximum number of driveways along arterial frontage should be:

Maximum Number of Driveways Along Arterial Frontage	
FRONTAGE (FEET)	NO. OF DRIVEWAYS
0 to 200	1 <sup>1</sup>
200+ to 400	2

For every additional 400 feet of frontage, 1 additional driveway is allowed. However, for minimum distance between driveways see Sub-Section V.D. Exceptions may be granted by the Transportation Engineer in charge based on review of specific project design or capacity needs (see Appendix A).

#### B. Location of Driveways Adjacent to Intersections

Driveways should be located such that two-way left turn lane channelization will provide storage space for left-turn entry, and for refuge for left-turn exiting. Where the arterial does not have two-way left turn lane median channelization, the driveway should be as far from the intersecting street as possible.

Driveways on arterial highways serving lots with frontages greater than 250 feet should not be placed within 150 feet of the adjacent street. Driveways on collector or local streets serving lots with frontages greater than 250 feet should not be placed within 75 feet of the adjacent street.

Turning prohibitions should be considered on approvals whenever the following would occur and an alternate ingress/egress point is not available:

- a) Entering vehicles would need to make left-turns from the number one thorough lane of an arterial highway.
- b) Exiting vehicles making left-turns to an arterial highway would be required to turn through the queue from adjacent signalized intersections and the exiting vehicle would cross a left-turn lane or on an unchannelized street from within 150 of the crosswalk at the signal.
- c) When the proposed driveway causes a signalized T-intersection to become a left-jogged intersection and the proposed driveway becomes the right-jogged jog, the exiting driveway vehicles making left-turn movements shall be prohibited unless a new design for the newly-formed left-jogged intersection will signalize both jogged legs.

Where alternate access does not exist for a proposed driveway, turn restrictions may be considered, as authorized by the Transportation Engineer of the appropriate district office of the Transportation Engineer of the Signal Systems and Research Section.

---

<sup>1</sup> Two driveways may be approved if they are to each be one-way (i.e. one ingress only and one egress only).

PAGE 4	DATE 02/2003	SECTION 321	SUBJECT DRIVEWAY DESIGN	Department of Transportation MANUAL OF POLICIES & PROCEDURES
-----------	-----------------	----------------	----------------------------	---

Modifications to channelization to make proposed driveway locations acceptable shall be paid for by the permittee requesting the change, prior to approval of the permit. Such modifications shall be approved by the Transportation Engineer of the appropriate district office.

#### C. Driveways at Tee Intersections

Driveways for properties at the top of a "T" intersection are to be centered within one foot of the prolongation of the terminating street center line. The driveway at the top of the T-intersection should be a Case 3 type driveway in a residential area, and a Case 4 type driveway in a commercial area (see attached Department of Public Works Standard Plan No. S-440-3). Where this is not possible, the driveway should conform to Sub-Section V.B (Location of Driveways Adjacent to Intersections).

#### D. Distance between Driveways

Wherever possible, two-way driveways should be separated by a minimum of 50 feet of full height curb to minimize conflict between vehicles using the adjoining driveways.

### VI. Driveway Design

#### A. Basic Principles

Driveways should be designed to minimize possible conflicts between users of parking facilities and users of abutting street systems. The design should address pedestrian safety, sight distance, width of the lane from which the right turns into the driveway are made (i.e. 12 foot curb lane requires a wider driveway), size and turning characteristics of vehicles using the driveway (i.e. delivery trucks require wider driveways), complexity of vehicular movements, density of traffic on the abutting street (traffic and street width), speed of vehicles on the abutting street, arrival or departure rate of vehicles using the driveway, and any other considerations that would affect the safety and efficient use of City streets. It should be recognized that driveway design recommendations may vary depending upon site constraints, location, and usage. Existing driveways can be approved as constructed if the project which has necessitated their review is of limited scope or is re-striping only.

#### B. Width of Driveways

Notwithstanding existing Code requirements, the following driveway widths are recommended:

**Recommended Widths of Driveways**  
(*W* dimension of driveway apron, in feet)<sup>2</sup>

Type of Development	Two-Way	One-Way
Commercial	30 ft	16 ft
Industrial	30 ft	16 ft
Single Family Residential		
1 or 2 car garage	18 ft	–
3 or more car garage	26 ft	–
Multi-Family Residential		
More than 25 spaces	30 ft	16 ft
5 to 25 spaces	28 ft	16 ft
Less than 5 spaces	18 ft	16 ft

These recommended widths assume standard passenger vehicles turning right from an 18 foot wide curb lane under typical conditions. Wider driveways may be appropriate to accommodate large commercial vehicles or multiple entry lanes. Shorter driveway widths may be considered where it may be more appropriate to use narrower driveway or field conditions preclude use of recommended widths.

When larger vehicles and trucks are going to be the predominant users of a particular driveway, turning templates shall be utilized to develop a driveway width that can safely and expeditiously accommodate the prevalent type of ingress and egress traffic.

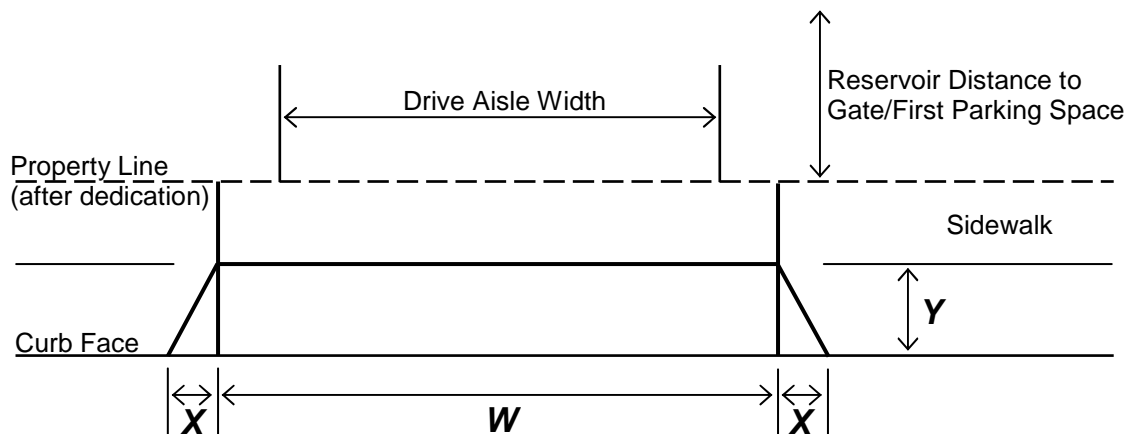

<sup>2</sup> See attached Department of Public Works Standard Plan No. S-440-3.

Driveway widths (*W* dimension) are intended to facilitate turning movements such that vehicles entering and exiting do not interfere with one another. The *W* dimension will commonly be larger than the on-site aisle width. This allows vehicles to enter from or to curb lanes without interfering with one another or hitting the *X* (sloping) portion of the curb.

### C. Street-Type Driveways

Where a large parking facility is being constructed with signalized access along an arterial highway, a street-type driveway (i.e. having curb returns instead of sloping sides) with full height curb returns approximately 25 feet in radii will be required if the expected peak volume exceeds 250 cars per hour or 50 trucks per hour<sup>3</sup> or a traffic signal with normal signal operation is designed for the driveway. Standard driveway design may be used for driveways with signal flashing red operations. All new traffic signals must be warranted and approved by the Bureau of Traffic Management of DOT.

### D. One-Way Driveways

One-way driveways should be permitted only if one-way-only usage is assured by:

1. Angled parking stalls, or
2. Other positive control (e.g. tire spikes or mechanical gate).

### E. Reservoir and Maneuvering Space

Any entrance driveway from an arterial highway should provide reservoir space between the back of the sidewalk and the first parking stall.

#### Minimum Clear Reservoir Distance (feet)

<u>Total Spaces</u>	<u>Reservoir</u>
Up to 100	20
101 to 300	40
More than 300	60

Where more than 300 parking spaces are provided or where ticket dispensers and/or mechanical gates are used, the reservoir should be based upon calculated “traffic intensity” for each street access (see Appendices A & B). Gates or guard booths should be set back far enough from the back of the sidewalk to ensure that entering or exiting vehicles will not block sidewalk, signalized crosswalks or extend into street. The reservoir distance between the driveway approach limit lines and gates/or guard booths should provide sufficient vehicle storage space for traffic queuing during the duration of red indication, if the driveway is controlled by a traffic signal with normal operations.

---

<sup>3</sup> Decisions require concurrence by Bureau of Engineering, Department of Public Works.



Department of Transportation MANUAL OF POLICIES & PROCEDURES	SUBJECT DRIVEWAY DESIGN	SECTION 321	DATE 02/2003	PAGE 7
---	----------------------------	----------------	-----------------	-----------

- F. Each parking space, parking area, or loading area should be located such that vehicle maneuvers can be accomplished without driving onto the public right-of-way, except an alley.
- G. Drive-up service windows should be designed as drive-out-only facilities with adequate storage off-street to accommodate waiting vehicles. Reservoir space should be based upon calculated "traffic intensity".

## VII. Internal Circulation

LAMC Section 12.21 A-5 (j) (see Appendix C) provides authority for DOT review of the Internal Circulation. "All portions of a public parking area or public garage shall be accessible to all other portions thereof without requiring the use of any public street, unless the Department of Transportation determines that such use is not detrimental to the flow of traffic." The purpose of this section is to prevent (or control) the use of public streets for circulating between one part of a parking facility and another. Exceptions to this policy:

- A. Residential Parking Areas – Parking areas for occupants of residential buildings are not "public," therefore, this section is not applicable to residential parking areas. Parking areas for visitors to residential buildings, however, are public. LAMC (Section 12.03).
- B. Off-site Parking Facilities – LAMC Section 12.21 A-4(g) (see Appendix C) permits the provision of parking facilities within a certain distance of the building site. This provides that off-site parking facilities may be separated by public streets. However, each such facility should conform to the internal circulation test.
- C. Employee Parking – Some parking for industrial or commercial facilities may be assigned (by a note on the building plans) "for use by employees only". However, in approving an exception, care should be taken to ensure that parking spaces are assigned and that the facility is not likely to be used for parking by customers or other visitors.

Parking stalls shall not be designed so that a vehicle is required to back out onto any public street or sidewalk. Parking stalls that serve two dwelling units or less with driveway access that is not from a major or secondary highway are exempt from this restriction. (LAMC Section 12.21 A-5 (i), see Appendix C)

## VIII. Loading Docks

In the review of plans for driveways or parking facilities, DOT also reviews the design, location, and adequacy of truck loading docks.

Back-in or back-out loading facilities should not be permitted along arterial highways or collector streets. It is the policy of this Department to approve only those designs which entirely remove loading operations from these classification of streets.

Back-in loading facilities may be permitted on commercially-developed local streets if off-street space is insufficient for truck maneuvering. These back-in loading facilities should have a minimum reservoir area of 45 feet back of sidewalk. If all or a portion of the back-in loading facility is within a building, the reservoir area should be depressed to prevent other use of the reservoir space.

## APPENDIX A – PARKING CONTROL SERVICE RATE

### Typical Service Rates Per Lane<sup>4</sup>

<u>Type of Control</u>	<u>Average Headway (Sec/Veh)</u>	<u>Capacity (Veh/Hr)</u>
<b>Entering:</b>		
Clear aisle, no control	3.6	1,000
Ticket dispenser, no gate	5.0	720
Time stamp and handed to driver	8.5	425
Coded-card operated gate	8.9	405
Cashier, flat fee, no gate		
No information given	9.2	390
Direction-info needed	14.8	250
Ticket dispenser with gate		
Sharp turn @ approach	9.5	380
Easy direct approach	5.5	650
Coin-operated gate	20.4	175
<b>Internal:</b>		
Clear aisle or ramp, no parking	2.0	1,800
Straight ramp w/bend @ end	2.2	1,650
Circular ramp, 30' R @ C/L	2.2	1,650
Aisle with adjacent 9' x 18' stalls		
Inbound	3.5	1,040
Outbound	8.6	420
<b>Exiting:</b>		
Light street congestion	7.2	500
Moderate street congestion	9.0	400
Coded card/token-operated gate	9.0	400
Cashier, flat fee with gate	13.4	270
Cashier, variable fee with gate	19.5	185
Coin operated gate	20.4	175

---

<sup>4</sup> Assumes no significant interference by pedestrians, other traffic, etc.

APPENDIX B

**RESERVOIR NEEDS  
VS. TRAFFIC INTENSITY**

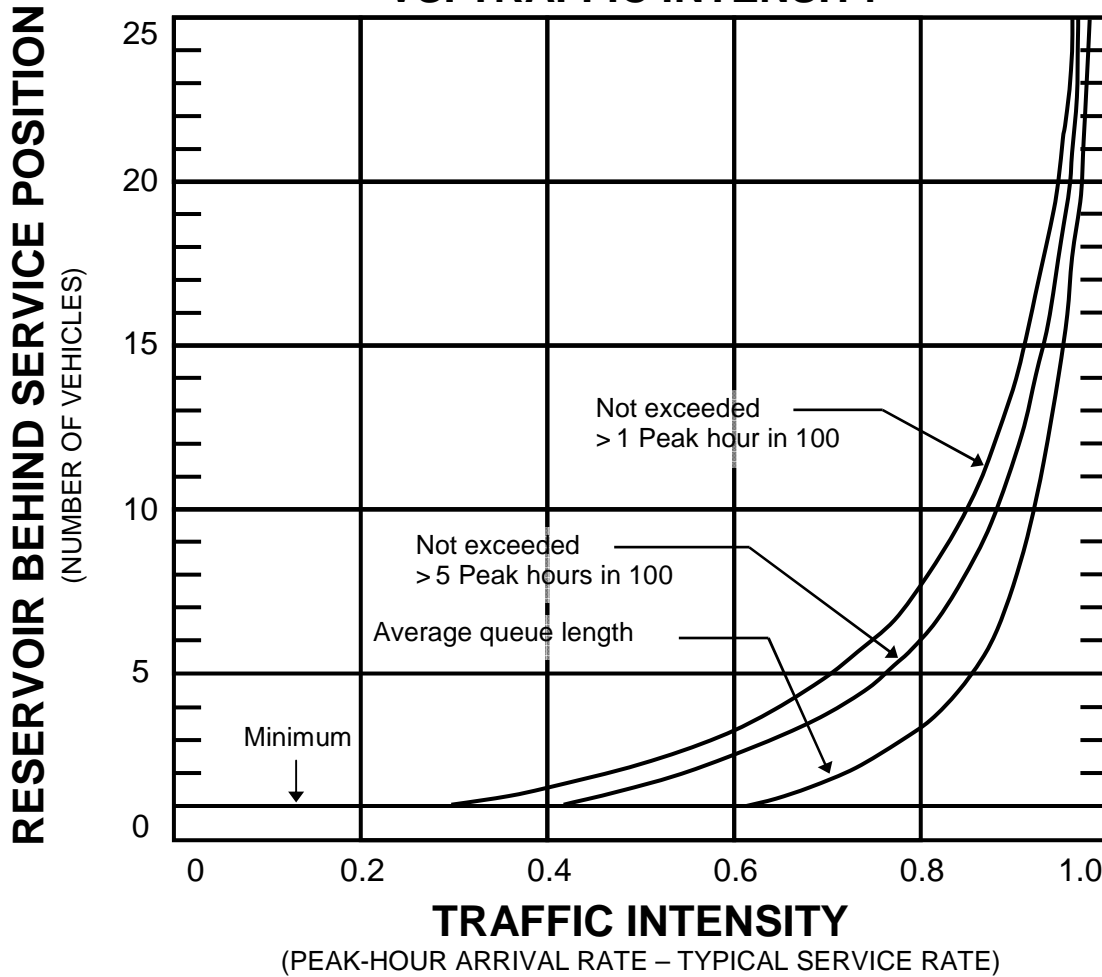

Assumptions: Arrivals follow a Poisson Distribution.  
Service rate can be represented by an exponential probability function.  
Flow is equally divided between each line if more than one is available.

Notes:

1. To obtain total reservoir length, use 20 feet per vehicle + 20 feet for the service position (or 12 feet to the driver of the vehicle in the service position).
2. For peak-hour arrival rate contact City-Wide Planning Coordination Section at (213) 482-7024.
3. See Appendix A for parking control service rate.

PAGE 10	DATE 02/2003	SECTION 321	SUBJECT DRIVEWAY DESIGN	Department of Transportation MANUAL OF POLICIES & PROCEDURES
------------	-----------------	----------------	----------------------------	---

## APPENDIX C – LOS ANGELES MUNICIPAL CODE REFERENCES

1. Section 12.21 A-4(g) Location of Parking Area. The automobile parking spaces required by paragraphs (b), (c), (d), and (e) hereof, shall be provided either on the same lot as the use for which they are intended to serve or on another lot not more than 750 feet distant therefrom; said distance to be measured horizontally along the streets between two lots, except that where the parking area is located adjacent to an alley, public walk or private easement which is easily useable for pedestrian travel between the parking area and the use it is to serve, the 750-foot distance may be measured along said alley, walk or easement (Amended by Ord. No. 145,088, Eff. 10/20/73.)
  
2. Section 12.21 A-5(e) Driveway Location. Access driveways to every parking area and garage shall be designated in accordance with Section 62.105.1, 62.105.2, 62.105.3 and 62.105.4 for this Code, and in a manner to provide the minimum practical interference with the use of adjacent property and with pedestrian or vehicular traffic.
 

Such driveways shall be located in accordance with a plan approved by the Department of Building and Safety in the following instances:

  - a. On a lot in a "P" (including any combination with an "A" or "R" Zone) or "PB" Zone.
  - b. For every parking area and garage having a capacity of more than 25 automobiles or trucks.

The Department of Building and Safety shall disapprove any plan which it determines fails to meet the standards established by this Paragraph.
  
3. Section 12.21 A-5(i) Parking stall Location. Each automobile parking stall shall be so located that:
  - a. No automobile is required to back onto any public street or sidewalk to leave the parking stall, parking bay or driveway, except where such parking stalls, parking bays or driveways serve not more than two dwelling units and where the driveway access is to a street other than a major or secondary highway. (Amended by Ord. No. 151,608, Eff. 11/27/78.)
  - b. Parking maneuvers can be accomplished without driving onto that portion of a required front yard where driveways are prohibited. Car stops or other barriers shall be provided in accordance with Section 12.21 A-6. (Amended by Ord. No. 144,082, Eff. 12/11/72.)
  
4. Section 12.21 A-5(j) Internal Circulation. All portions of a public parking area or public garage shall be accessible to all other portions thereof without requiring the use of any public street, unless the Department of Transportation determines that such use is not detrimental to the flow of traffic. (Amended by Ord. No. 152,425, Eff. 6/29/79.)
  
5. Section 12.21 C-6(a) Loading Space. A loading space shall be provided and maintained on the same lot with every hospital, hotel, or institution building. A loading space shall be provided and maintained on the same lot with every building in the "C" or "M" Zones, where the lot on which said building is located abuts an alley, provided that when the lot is occupied by a use, such as a service station or drive-in business, in which the building covers less than

Department of Transportation MANUAL OF POLICIES & PROCEDURES	SUBJECT DRIVEWAY DESIGN	SECTION 321	DATE 02/2003	PAGE 11
---	----------------------------	----------------	-----------------	------------

the total buildable area, a suitable loading space must be provided, but it need not comply with all the provisions of this section if its location, size and means of access are approved by the Department of Building and Safety.

EXCEPTION: No loading space shall be required on a lot that abuts an alley in the "C" or "M" Zones when all the buildings are erected, structurally altered, enlarged, or maintained and used solely as dwellings or apartment houses and the total number of dwelling units on the lot does not exceed 20. (Amended by Ord. No. 138,685, Eff. 7/10/69.)

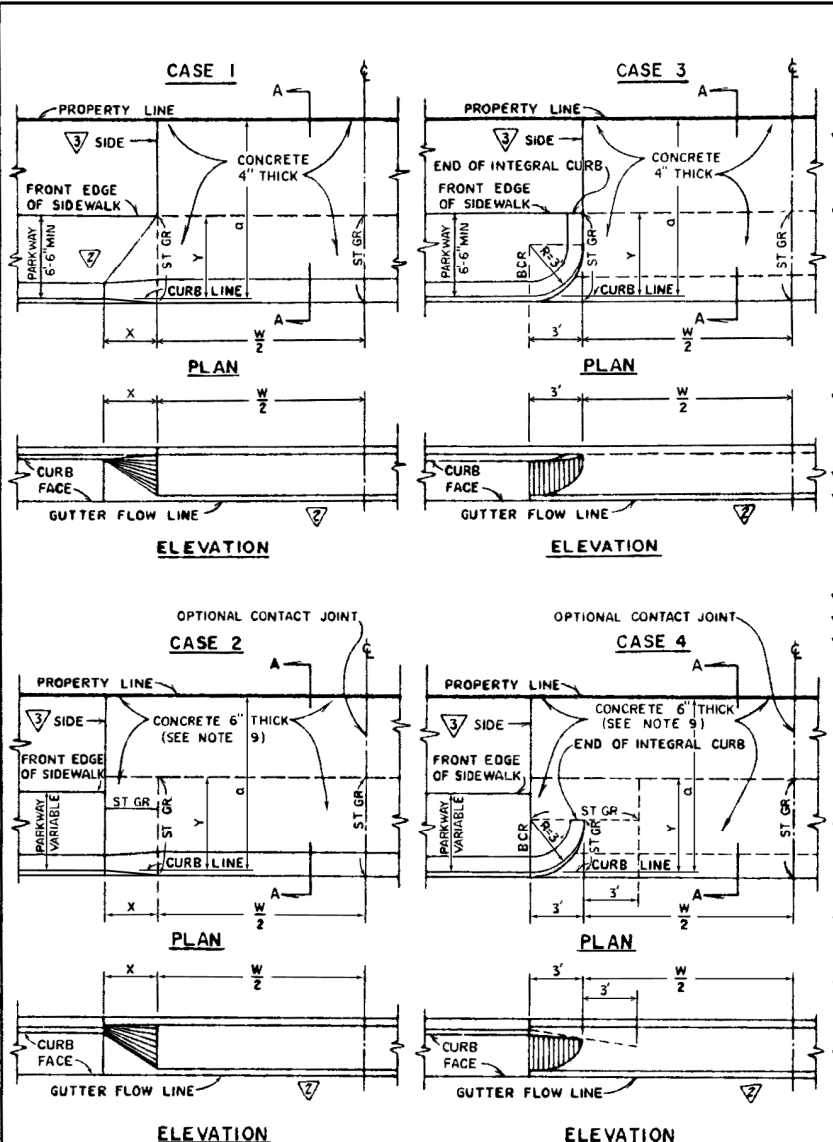

- NOTES
1. ALL WORK SHALL BE CONSTRUCTED IN ACCORDANCE WITH THE LATEST STANDARD SPECIFICATIONS.
  2. CASE 2 SHALL BE USED IN MOST CIRCUMSTANCES EXCEPT THAT CASE 1 MAY BE USED TO SERVICE R-1 OR R-2 PROPERTY PROVIDED THE "Y" SLOPE DOES NOT ENCRoACH INTO THE SIDEWALK.
  3. CASE 3 OR 4 SHALL BE USED IN LIEU OF CASE 1 OR CASE 2 RESPECTIVELY TO PRECLUDE THE FOLLOWING CONDITIONS.
    - A. A DISTANCE OF LESS THAN 5 FEET BETWEEN A PROPOSED TOP OF "X" AND THE CENTER LINE OF AN ELECTROLIER OR FIRE HYDRANT.
    - B. TRAFFIC SIGNALS, UTILITY POLES AND SIGN POSTS IN THE "X" AREA OF A PROPOSED DRIVEWAY.
  4. WHERE CASE 3 OR 4 IS USED, AN ELECTROLIER OR HYDRANT SHALL NOT BE CLOSER THAN 1'-6" FROM THE BC, AND A TRAFFIC SIGNAL, UTILITY POLE OR SIGN POST SHALL NOT BE CLOSER THAN THE BC.
  5. WHERE THERE IS EXISTING INTEGRAL CONCRETE CURB AND GUTTER, BOTH CURB AND GUTTER MUST BE REMOVED. OPTIONAL, IF THE GUTTER IS IN GOOD CONDITION, THE GUTTER MAY BE SAW CUT 4 INCHES TO 6 INCHES FROM THE FLOW LINE AND THE OUTSIDE PORTION LEFT IN PLACE, PROVIDING THAT IT IS NOT LESS THAN 18 INCHES.
  6. PLASTIC CONTROL WEAKENED-PLANE JOINTS SHALL BE INSTALLED AT BOTH SIDES OF A DRIVEWAY AND AT APPROXIMATELY 10' INTERVALS WITHIN THE DRIVEWAY. WHERE THE DISTANCE BETWEEN THE SIDES OF THE DRIVEWAY DOES NOT EXCEED 15', AN INTERMEDIATE WEAKENED-PLANE JOINT WILL NOT BE REQUIRED.
  7. THE AREA INCLUDED WITHIN THE "X" AND "Y" SLOPES (INCLUDING TOP OF CURB) WITHIN DRIVEWAY SHALL BE FINISHED WITH A WOOD FLOAT. THE BALANCE OF THE DRIVEWAY SHALL BE FINISHED IN ACCORDANCE WITH THE LATEST SPECIFICATIONS FOR SIDEWALK.
  8. SECTION B MAY BE USED WHEN A DRIVEWAY WHICH SERVICES R-1 OR R-2 PROPERTY JOINS EXISTING SIDEWALK IN GOOD CONDITION AND THERE IS ADEQUATE "Y" DISTANCE BETWEEN CURB AND EDGE OF SIDEWALK.
  9. A "t" OF 4-INCHES MAY BE USED FOR CASE 2 AND 4 DRIVEWAYS SERVING NOT MORE THAN FOUR DWELLING UNITS.
  10. FOR THE "W" WIDTH OF DRIVEWAYS, SEE SECTION 62.105.2 OF THE LOS ANGELES MUNICIPAL CODE.
  11. CURB FACE FOR DRIVEWAY DEPRESSION SHALL BE 3/4-INCH.

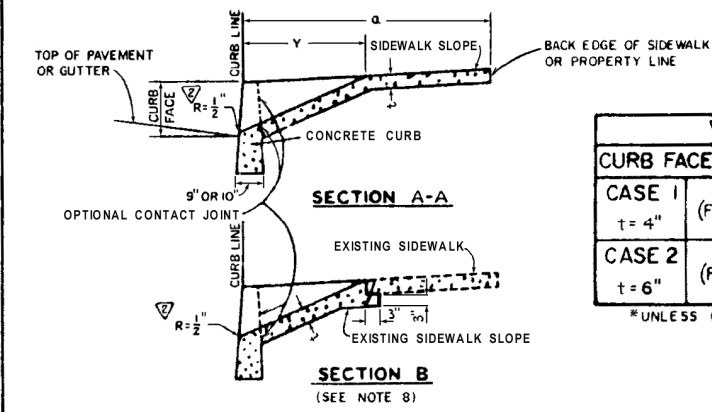

TABLE OF "X" & "Y" DIMENSIONS\*

CURB FACE (INCHES)	6 OR LESS	7	8	9	10	11	12 OR MORE
CASE 1 t = 4" (FEET)	X	3					
	Y	6 1/2		9	10	11	12
CASE 2 t = 6" (FEET)	X	3	3 1/2	4	4 1/2	5	5 1/2
	Y	6	7	8	9	10	11

\* UNLESS OTHERWISE APPROVED BY THE ENGINEER

**DEPARTMENT OF PUBLIC WORKS**

**BUREAU OF ENGINEERING** **CITY OF LOS ANGELES**

**DRIVEWAYS** **STANDARD PLAN S-440-3**

SUBMITTED: 7/29/76 1976	REVISIONS	SUPERSEDES	REFERENCES
NO. DATE DESCRIPTION	DIV ENGR CITY ENGR		
1 11-19-71 PLASTIC CONTROL JOINTS NOTE NO 6	J. J. Brown		D-14817 B-3788 B-3799 B-3815
2 7-31-74 REVISED NOTES REMOVED DIMENSION AT CURB FACE AND ELECTROLIER			
3 7-29-76 REVISED NOTES NO 5, 6 & 11 ADD THE WORD "SIDE"			
APPROVED: 12/29/76 1976			
DESIGNED BY: WDT	DRAWN BY: SJA	CHECKED BY: SS	
			Vault Index Number B-3890
			SHEET 1 OF 2 SHEETS

**CASE 1**

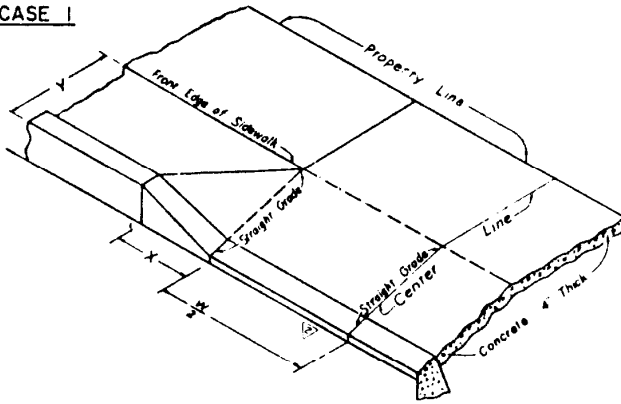

**CASE 2**

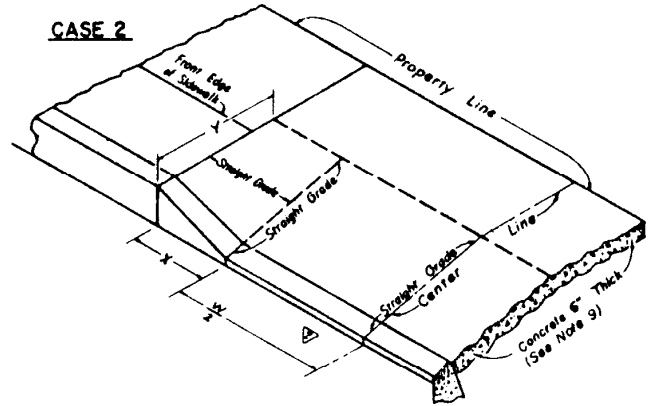

**CASE 3**

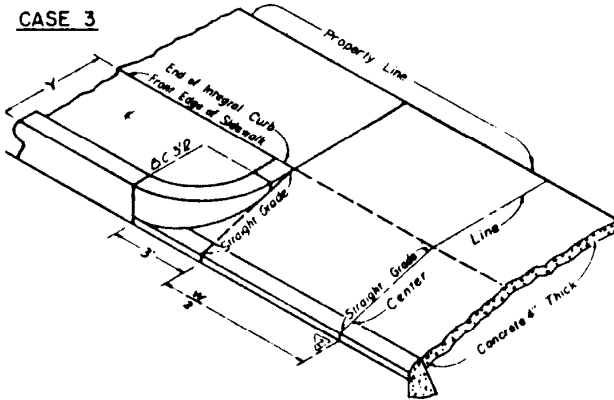

**CASE 4**

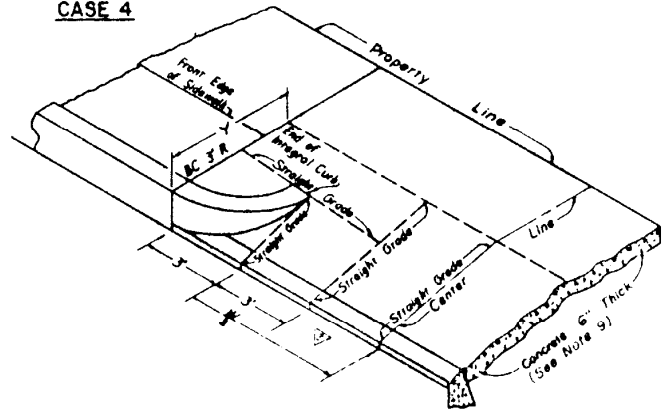

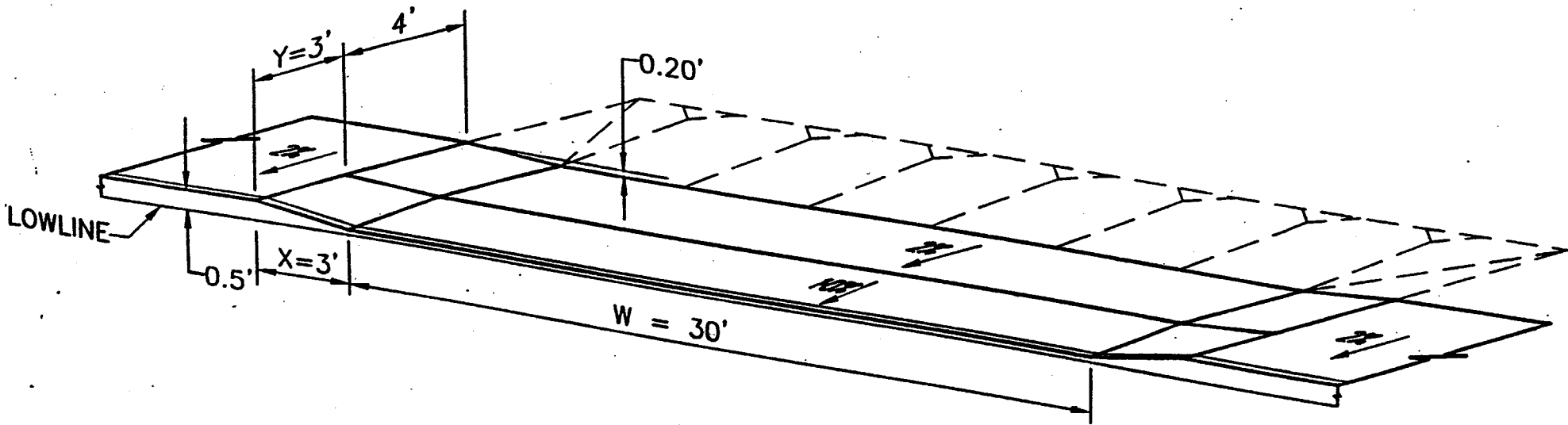

DRIVEWAY DETAIL

N.T.S.

**CASE II DRIVEWAY**

From  
Building & Safety Standard Plan No. S-440-3

**SAMPLE**



### ARTERIAL STREETS

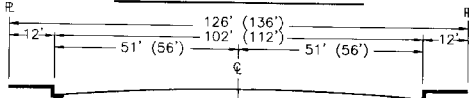

**MAJOR HIGHWAY-CLASS I**

At intersections with other Major Highways, the larger widths shown in parentheses should be provided, as determined by LADOT, utilizing a Standard Flare Section.

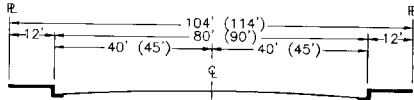

**MAJOR HIGHWAY-CLASS II**

At intersections where LADOT has determined that dual left turn lanes are required, the larger widths shown in parentheses shall be provided, utilizing a Standard Flare Section.

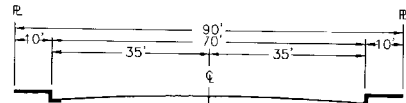

**SECONDARY HIGHWAY**

### TRANSITIONAL EXTENSIONS

Where a designated Major Highway (Class I or II) or a Secondary Highway crosses another designated arterial street and then changes in designation to a street of lesser standard width, the street of lesser standard width shall be widened on both sides from the intersection to the width of the higher designation and tapered in a Standard Flare Section, as shown below, to provide an orderly transition.

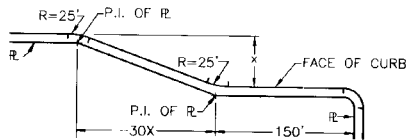

Dimensions shall be measured angle point to angle point.

**STANDARD FLARE SECTION (Plan View)**

### ALLEYS

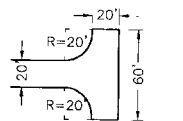

**STANDARD TURNING AREA (Plan View)**

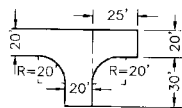

**MINIMUM TURNING AREA (Plan View)**

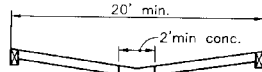

**STANDARD CROSS-SECTION**

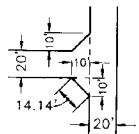

**STANDARD CUT-CORNERS FOR 90° INTERSECTION (Plan View)**

NOTE: Dimensions shown hereon are not to scale.

### NON-ARTERIAL STREETS

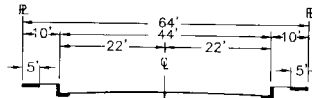

**COLLECTOR STREET**

For use in quarter mile streets and school areas.

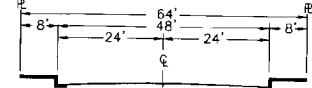

**INDUSTRIAL COLLECTOR STREET**

For use in industrial areas to assist the flow of local truck traffic within those areas to adjacent arterial streets. A 35' curb return radius is required.

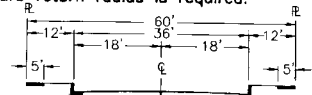

**LOCAL STREET**

In commercial and multiple residential areas, a 40-foot roadway with 10-foot parkways, and full-width sidewalks shall be required.

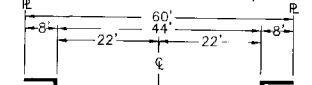

**INDUSTRIAL LOCAL STREET**

For use in industrial areas. A 35' curb return radius is required.

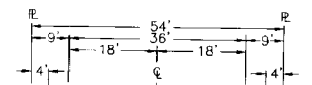

**NONCONTINUOUS LOCAL STREET**

May include cul-de-sac, loop streets and short connector streets. Where an approved internal pedestrian system is provided the parkway on one side may be reduced to 3-feet.

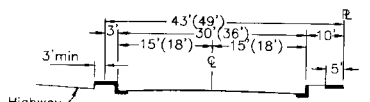

**SERVICE ROAD**

For use on adjoining major or secondary highways, except that the larger widths shown in parentheses shall be provided in multiple residential zones.

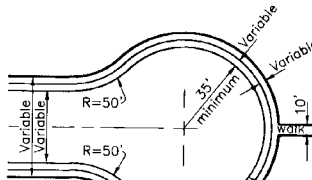

**CUL-DE-SAC (Plan View)**

MAY BE UNSYMMETRICAL

Note: For fire truck clearance, no obstruction taller than 6" shall be permitted within 3 ft. of the curb. On-street parking shall be prohibited.

### HILLSIDE STREETS

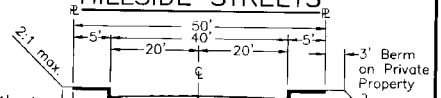

**HILLSIDE COLLECTOR STREET**

3' Berm on Private Property

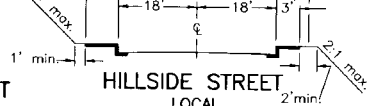

**HILLSIDE STREET LOCAL**

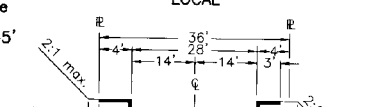

**HILLSIDE STREET LIMITED**

(Parking on one side only)

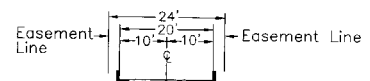

**ACCESS ROADWAY CONDITIONAL**

(Limited to 4 dwelling units, and a maximum length of 300 feet. Private Street only)



**STANDARD WALKWAY CROSS - SECTION**

PREPARED IN COOPERATION WITH THE DEPARTMENTS OF TRANSPORTATION AND CITY PLANNING

BUREAU OF ENGINEERING

DEPARTMENT OF PUBLIC WORKS

CITY OF LOS ANGELES

## STANDARD STREET DIMENSIONS

**STANDARD PLAN S-470-0**

SUBMITTED	March 23, 1999
ENGINEER OF DESIGN	Clark W. Robins
DEPUTY ENGINEER	Robynne...
APPROVED	MARSH S. Thomas Conner
CITY ENGINEER	
DESIGNED BY	DRAWN BY
CHECKED BY	
M.F.O. G.L.F., J.E.F. A.D.R.	R. TANABE L. GANAJA



APPROVED	Francis Benitez	4.6.99
GENERAL MANAGER, DEPT. OF TRANSPORTATION		DATE
	Constance	4/6/99
DIRECTOR OF PLANNING		DATE
ADOPTED		MAY 13, 1999
CITY PLANNING COMMISSION		DATE

SUPERSEDES	REFERENCES
D-22549	
VAULT INDEX NUMBER	
B-4428	
SHEET 1 OF 2 SHEETS	

THIS STANDARD PLAN BECOMES EFFECTIVE ON NOVEMBER 10, 1999

## STANDARD STREET CONDITIONS

1. City Council may, by ordinance, adopt specific standards for individual streets which differ from these official standard street dimensions. Community Plans should be reviewed for designation of Pedestrian Priority Street Segments of arterial streets which would require wider sidewalks than those indicated on this Standard Plan.
2. Sidewalk widths for non-arterial streets shall be the minimum shown hereon. Greater widths, up to full width between curb and property line, with tree wells, shall be required where commercial and multiple residential frontage, schools, areas of heavy pedestrian traffic or other special circumstances indicate the need.
3. Except for special conditions or as otherwise provided, sidewalk shall be placed as close to the property line as possible.
4. Where sidewalk is constructed adjacent to the curb it shall have a minimum width of 10 feet inclusive of curb thickness except for hillside streets, noncontinuous local streets and industrial streets.
5. Where sidewalk is constructed on the fill or low side of a hillside street, a berm may be required on private property.
6. Easements may be required in addition to the widths shown hereon, where necessary for the installation of public utilities or for widened sidewalks (minimum 15-foot width) adjacent to transit stations.
7. Fifty-foot curb radii (instead of the standard 35' curb radii) shall be provided for cul-de-sacs in industrial areas.
8. Private street development should conform to the standard public street dimensions shown on this sheet, where appropriate. Variations may be approved on a case-by-case basis.
9. For intersections of streets the following dedications shall apply:
  - a. Intersections of arterial streets with any other street: 15'x15' cut corner OR 20' curved corner radius.
  - b. Intersections of non-arterial and/or hillside streets: 10'x10' cut corner OR 15' curved corner radius.
10. Hillside Collector Streets. In hillside areas where topography or other environmental considerations, documented to the satisfaction of the City Engineer, would render full street improvements infeasible, the roadway width of the hillside collector street may be reduced to no less than 32 feet, provided that parking is limited to one side only.

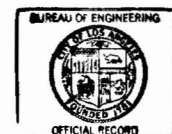

**ATTACHMENT E**

**TRAFFIC STUDY - MEMORANDUM OF UNDERSTANDING (MOU)**

This MOU acknowledges that the traffic study for the following project will be prepared in accordance with the latest version of LADOT's Traffic Study Policies and Procedures:

Project Name: \_\_\_\_\_  
 Project Address: \_\_\_\_\_  
 Project Description: \_\_\_\_\_

Geographic Distribution: N \_\_\_\_ % S \_\_\_\_ % E \_\_\_\_ % W \_\_\_\_ %  
 Attach graphic illustrating project trip distribution percentages at the studied intersections

Trip Generation Rate(s): ITE 8th Edition / Other \_\_\_\_\_  
 Attach trip generation table with a description of the proposed land uses, ITE rates, estimated morning and afternoon peak hour volumes (ins/outs/totals), proposed trip credits, etc.

	<u>in</u>	<u>out</u>	total
AM Trips	_____	_____	_____
PM Trips	_____	_____	_____

Project Buildout Year: \_\_\_\_\_ Ambient or CMP Growth Rate: \_\_\_\_\_ % Per Yr.  
 Related Projects: \_\_\_\_\_ (to be researched by the consultant and approved by LADOT)

**Study Intersections**  
 (Subject to LADOT revision after initial impact analysis)

1.	6.
2.	7.
3.	8.
4.	9.
5.	10.

Trip Credits: (Exact amount of credit subject to approval by LADOT)

	Yes	No
Transit Usage		
Transportation Demand Management		
Existing Active Land Use		
Previous Land Use		
Internal Trip		
Pass-By Trip		

<b>Consultant</b>		<b>Developer</b>	
Name _____	_____	_____	_____
Address _____	_____	_____	_____
Phone No. _____	_____	_____	_____

Approved by: \_\_\_\_\_ Date \_\_\_\_\_  
 Consultant's Representative LADOT Representative Date

# **ATTACHMENT F**

## **TRAFFIC STUDY MAPS AND FIGURES**

The traffic study should include the following maps unless otherwise specified during the scoping process:

1. Area map showing Project location.
2. Area map showing location of related projects (table should be included indicating location, size, name, description and trip generation of each related project).
3. Site map showing study intersections and distance of the Project driveway(s) from the adjacent intersections. Include location and identification of all major buildings, driveways, parking areas and loading docks of the Project.
4. Map(s) showing the "existing" (specify base year) traffic volumes for both the a.m. and p.m. peak hours at the study intersections and the average daily traffic (ADT) on any analyzed street segments.
5. Map(s) showing future traffic volumes with ambient growth without Project at the study intersections and street segments. This map should specify the future year used in the impact analysis and should be based on the expected date of project buildout. The future year identified in this step shall remain consistent for all other maps described below that illustrate future traffic projections.
6. Map(s) showing traffic generated by the related projects only. Use separate map for similar land uses (e.g. retail, office, residential, industrial/manufacturing) with similar trip distribution patterns (as they affect the study intersections and freeway locations).
7. Map(s) showing total future "cumulative base" traffic volumes without Project at the study intersections, freeway locations and street segments (add steps 5 and 6).
8. Map(s) showing Project trip distribution percentages (inbound and outbound) at the study intersections, freeway locations and project driveway(s). This map must be pre-approved by LADOT and included in the MOU.
9. Map(s) showing estimated Project-only traffic volumes at the study intersections, Project driveway(s), freeway locations and street segments.
10. Map(s) showing total existing traffic volumes with Project at the study intersections, project driveway(s), freeway locations and street segments (add steps 4 and 9).
11. Map(s) showing total future traffic volumes with Project at the study intersections, project driveway(s), freeway locations and street segments (add steps 7 and 9).
12. Map showing existing and projected transit lines.

**ATTACHMENT G**

**Traffic Study Checklist**

The following checklist highlights key requirements that are critical to LADOT's review of the traffic study in addition to the requirements listed in the Traffic Study Policies and Procedures. To avoid any delays in the review process, please provide the following:

- Hard copy and PDF electronic copy of the traffic study
- Legible site plan showing driveway locations, loading/unloading area, and any proposed highway dedication and widening
- Traffic study review fee
- Conceptual drawings of the proposed mitigation measures in hard copy and PDF electronic copy
- Traffic volumes counts in LADOT format
- City Planning Case Number (if applicable)
- Existing-use documentation (i.e., certificate of occupancy, lease agreements, utility bills, etc.)
- Traffic signal warrant sheets (if applicable)
- Traffic study shall be stamped by a Registered Traffic Engineer

LADOT Use Only

“Deemed Complete” by: \_\_\_\_\_ Date: \_\_\_\_\_

# ATTACHMENT H



City Of Los Angeles  
Department Of Transportation

## MANUAL TRAFFIC COUNT SUMMARY

STREET:

**North/South**     BROADWAY

**East/West**     75TH ST

**Day:**     MONDAY     **Date:**     JULY 16, 2007     **Weather:**     SUNNY

**Hours:**     7-10AM 2-5PM

**School Day:**     YES     **District:**     CENTRAL     **I/S CODE**     1451

	<u>N/B</u>	<u>S/B</u>	<u>E/B</u>	<u>W/B</u>
<b>DUAL-WHEELED BIKES</b>	101	139	3	6
<b>BUSES</b>	0	11	0	0
	0	98	0	0

	<u>N/B TIME</u>	<u>S/B TIME</u>	<u>E/B TIME</u>	<u>W/B TIME</u>
<i>AMPK 15 MIN</i>	329   7.15	168   7.45	5   8.00	28   7.15
<i>PMPK 15 MIN</i>	174   2.15	273   4.45	12   2.15	56   2.30
<i>AMPK HOUR</i>	1230   7.15	625   7.15	14   7.15	106   7.15
<i>PMPK HOUR</i>	609   2.00	1002   4.00	33   2.00	111   2.15

**NORTHBOUND Approach**

Hours	Lt	Th	Rt	Total
7-8	7	1056	94	1157
8-9	4	806	63	873
9-10	2	529	10	541
2-3	9	518	82	609
3-4	5	448	19	472
4-5	8	514	21	543
<b>TOTAL</b>	35	3871	289	4195

**SOUTHBOUND Approach**

Hours	Lt	Th	Rt	Total
7-8	47	550	11	608
8-9	32	459	5	496
9-10	10	374	4	388
2-3	33	679	12	724
3-4	30	816	16	862
4-5	20	973	9	1002
<b>TOTAL</b>	172	3851	57	4080

**TOTAL**

**XING S/L**

**XING N/L**

N-S	Ped	Sch	Ped	Sch
1765	63	25	0	0
1369	30	8	2	0
929	4	0	1	0
1333	89	40	0	0
1334	12	4	4	0
1545	16	0	5	0
8275	214	77	12	0

**EASTBOUND Approach**

Hours	Lt	Th	Rt	Total
7-8	1	2	10	13
8-9	2	2	4	8
9-10	6	0	7	13
2-3	6	5	22	33
3-4	6	6	10	22
4-5	9	4	9	22
<b>TOTAL</b>	30	19	62	111

**WESTBOUND Approach**

Hours	Lt	Th	Rt	Total
7-8	43	4	54	101
8-9	32	2	34	68
9-10	18	1	19	38
2-3	42	5	60	107
3-4	34	2	27	63
4-5	32	5	27	64
<b>TOTAL</b>	201	19	221	441

**TOTAL**

**XING W/L**

**XING E/L**

E-W	Ped	Sch	Ped	Sch
114	70	39	45	2
76	46	11	35	1
51	30	3	12	0
140	103	100	74	25
85	63	18	38	7
86	48	11	32	0
552	360	182	236	35

**ATTACHMENT I**

**LADOT POLICY ON PASS-BY TRIPS**

<b>PASS-BY TRIP DISCOUNT RATE</b>	<b>LAND USE CATEGORY</b>
10%	Shopping Center 600,000 sf or more, Quality Restaurant, Specialty Retail, Furniture Store, Medical Office, Day Care, Theater/Cinema, Auto Sales/Repair
15%	Discount Club, Discount Store
20%	Shopping Center 300,000 to less than 600,000 sf, Bank/Savings & Loan, High Turnover Restaurant, Car Wash, Hardware/Lumber Store, Garden Center, Recreation/Health Club
30%	Shopping Center 100,000 to less than 300,000 sf, Auto Parts, Music/Video Store
40%	Shopping Center 50,000 to less than 100,000 sf, Supermarket, Drugstore, Bookstore
50%	Shopping Center less than 50,000, Fast Food Restaurant, Gasoline/Service Station, Convenience Market, Flower/Bakery/Yogurt Shop, Dry Cleaner, Liquor Store



# ATTACHMENT J

## Level of Service Worksheet (Circular 212 Method)



VS #:	North-South Street: <b>Glendale Boulevard</b>		Year of Count: <b>2009</b>		Ambient Growth: (%): <b>0.75</b>		Conducted by: <b>Chris</b>		Date: <b>8/10/2011</b>										
	East-West Street: <b>Temple Street</b>		Projection Year: <b>2020</b>		Peak Hour: <b>PM</b>		Reviewed by: <b>Chris</b>		Project: <b>TESTING ONLY</b>										
No. of Phases: <b>3</b> Opposed Sign: N/S-1, E/W-2 or Both-3? <b>0</b> Right Turns: FREE-1, NRTOR-2 or OLA-3? <b>NB-- 0 SB-- 0 EB-- 0 WB-- 0</b> ATSAAC-1 or ATSAAC+ATCS-2? <b>1</b> Override Capacity <b>0</b>			<b>3</b> <b>0</b> <b>0</b> <b>1</b> <b>0</b>			<b>3</b> <b>0</b> <b>0</b> <b>1</b> <b>0</b>			<b>3</b> <b>0</b> <b>0</b> <b>1</b> <b>0</b>										
MOVEMENT	EXISTING CONDITION			EXISTING PLUS PROJECT			FUTURE CONDITION W/O PROJECT				FUTURE CONDITION W/ PROJECT				FUTURE W/ PROJECT W/ MITIGATION				
	Volume	No. of Lanes	Lane Volume	Project Traffic	Total Volume	Lane Volume	Added Volume	Total Volume	No. of Lanes	Lane Volume	Added Volume	Total Volume	No. of Lanes	Lane Volume	Added Volume	Total Volume	No. of Lanes	Lane Volume	
<b>NORTHBOUND</b>	Left	60	1	60	5	65	65	0	65	1	65	0	65	1	65	0	65	1	65
	Left-Through		0						0				0				0		
	Through	1642	1	831	141	1783	902	93	1876	1	949	15	1891	1	956	0	1891	1	956
	Through-Right		1						1				1				1		
	Right	19	0	19	2	21	21	0	21	0	21	0	21	0	21	0	21	0	21
	Left-Through-Right		0						0				0				0		
	Left-Right		0						0				0				0		
<b>SOUTHBOUND</b>	Left	83	1	83	7	90	90	76	166	1	166	0	166	1	166	0	166	1	166
	Left-Through		0						0				0				0		
	Through	716	1	462	61	777	501	155	932	1	579	0	932	1	579	0	932	1	579
	Through-Right		1						1				1				1		
	Right	207	0	207	18	225	225	0	225	0	225	0	225	0	225	0	225	0	225
	Left-Through-Right		0						0				0				0		
	Left-Right		0						0				0				0		
<b>EASTBOUND</b>	Left	29	1	29	2	31	31	0	31	1	31	0	31	1	31	0	31	1	31
	Left-Through		0						0				0				0		
	Through	565	1	401	48	613	435	107	720	1	507	0	720	1	507	0	720	2	360
	Through-Right		1						1				1				1		
	Right	237	0	237	20	257	257	37	294	0	294	0	294	0	294	0	294	1	262
	Left-Through-Right		0						0				0				0		
	Left-Right		0						0				0				0		
<b>WESTBOUND</b>	Left	317	1	317	27	344	344	0	344	1	344	0	344	1	344	0	344	1	344
	Left-Through		0						0				0				0		
	Through	665	1	371	57	722	403	186	908	1	496	0	908	1	496	0	908	1	496
	Through-Right		1						1				1				1		
	Right	77	0	77	7	84	84	0	84	0	84	0	84	0	84	0	84	0	84
	Left-Through-Right		0						0				0				0		
	Left-Right		0						0				0				0		
<b>CRITICAL VOLUMES</b>			<i>North-South:</i> 914 <i>East-West:</i> 718 <i>SUM:</i> 1632	<i>North-South:</i> 992 <i>East-West:</i> 779 <i>SUM:</i> 1771	<i>North-South:</i> 1115 <i>East-West:</i> 851 <i>SUM:</i> 1966	<i>North-South:</i> 1122 <i>East-West:</i> 851 <i>SUM:</i> 1973	<i>North-South:</i> 1122 <i>East-West:</i> 704 <i>SUM:</i> 1826												
<b>VOLUME/CAPACITY (V/C) RATIO:</b>			1.145	1.243	1.380	1.385	1.281												
<b>V/C LESS ATSAAC/ATCS ADJUSTMENT:</b>			<b>1.075</b>	<b>1.173</b>	<b>1.310</b>	<b>1.315</b>	<b>1.211</b>												
<b>LEVEL OF SERVICE (LOS):</b>			<b>F</b>	<b>F</b>	<b>F</b>	<b>F</b>	<b>F</b>												

REMARKS:

Version: 1i Beta; 8/4/2011

### PROJECT IMPACT

Change in v/c due to project: **0.005**      Δv/c after mitigation: **-0.099**  
 Significant impacted? **NO**      Fully mitigated? **N/A**





## **ATTACHMENT L**

### **TRANSPORTATION DEMAND MANAGEMENT AND TRIP REDUCTION MEASURES** *(LAMC Section 12.26-J - amended by Ordinance 168,700)*

#### **1. DEFINITIONS**

For the purpose of this section, certain words and terms are defined as follows:

**Carpool.** A vehicle carrying two to five persons to and from work on a regular schedule.

**Development.** The construction of new non-residential floor area.

**Gross Floor Area.** That area in square feet confined within the outside surface of the exterior walls of a building, as calculated by adding the total square footage of each of the floors in the building, except for that square footage devoted to vehicle parking and necessary interior driveways and ramps.

**Preferential Parking.** Parking spaces, designated or assigned through use of a sign or painted space markings for Carpools or Vanpools, that are provided in a location more convenient to the entrance for the place of employment than parking spaces provided for single-occupant vehicles.

**Transportation Demand Management (TDM).** The alteration of travel behavior through programs of incentives, services, and policies, including encouraging the use of alternatives to single-occupant vehicles such as public transit, cycling, walking, carpooling/vanpooling and changes in work schedule that move trips out of the peak period or eliminate them altogether (as in the case in telecommuting or compressed work weeks).

**Trip Reduction.** Reduction in the number of work-related trips made by single-occupant vehicles.

**Vanpool.** A vehicle carrying six or more persons to and from work on a regular schedule, and on a prepaid basis.

**Vehicle.** Any motorized form of transportation, including but not limited to automobiles, vans, buses and motorcycles.

#### **2. APPLICABILITY**

This subdivision applies only to the construction of new non-residential gross floor area. Prior to the issuance of a building permit, the owner/applicant shall agree, by way of a covenant that runs with the land, to provide and maintain in a state of good repair the following applicable transportation demand management and trip reduction measures.

#### **3. REQUIREMENTS**

(a) **Development in excess of 25,000 square feet of gross floor area.** The owner shall provide a bulletin board, display case, or kiosk (displaying transportation information) where the greatest number of employees are likely to see it. The transportation information displayed should include, but is not limited to, the following:

- (1) Current routes and schedules for public transit serving the site;
- (2) Telephone numbers for referrals on transportation information including numbers for the regional ridesharing agency and local transit operations;
- (3) Ridesharing promotion material supplied by commuter-oriented organizations;
- (4) Regional/local bicycle route and facility information;
- (5) A listing of on-site services or facilities which are available for carpoolers, vanpoolers, bicyclists, and transit riders.

- (b) **Development in excess of 50,000 square feet of gross floor area.** The owner shall comply with Paragraph (a) above and in addition shall provide:
- (1) A designated parking area for employee carpools and vanpools as close as practical to the main pedestrian entrance(s) of the building(s). This area shall include at least ten percent of the parking spaces required for the site. The spaces shall be signed and striped sufficient to meet the employee demand for such spaces. The carpool/vanpool parking area shall be identified on the driveway and circulation plan upon application for a building permit;
  - (2) One permanent, clearly identified (signed and striped) carpool/vanpool parking space for the first 50,000 to 100,000 square feet of gross floor area and one additional permanent, clearly identified (signed and striped) carpool/vanpool parking space for any development over 100,000 square feet of gross floor area;
  - (3) Parking spaces clearly identified (signed and striped) shall be provided in the designated carpool/vanpool parking area at any time during the building's occupancy sufficient to meet employee demand for such spaces. Absent such demand, parking spaces within the designated carpool/vanpool parking area may be used by other vehicles;
  - (4) No signed and striped parking spaces for carpool/vanpool parking shall displace any handicapped parking;
  - (5) A statement that preferential carpool/vanpool spaces are available on-site and a description of the method for obtaining permission to use such spaces shall be included on the required transportation information board;
  - (6) A minimum vertical clearance of 7 feet 2 inches shall be provided for all parking spaces and access ways used by vanpool vehicles when located within a parking structure;
  - (7) Bicycle parking shall be provided in conformance with Section 12.21A16 of this Code.
- (c) **Development in excess of 100,000 square feet of gross floor area.** The owner shall comply with Paragraphs (a) and (b) above and shall provide:
- (1) A safe and convenient area in which carpool/vanpool vehicles may load and unload passengers other than in their assigned parking area;
  - (2) Sidewalks or other designated pathways following direct and safe routes from the external pedestrian circulation system to each building in the development;
  - (3) If determined necessary by the City to mitigate the project impact, bus stop improvements shall be provided. The City will consult with the local bus service providers in determining appropriate improvements. When locating bus stops and/or planning building entrances, entrances shall be designed to provide safe and efficient access to nearby transit stations/stops;
  - (4) Safe and convenient access from the external circulation system to bicycle parking facilities on-site.

#### 4. EXCEPTIONS

The provisions of this subsection shall not apply to developments for which an application has been deemed complete by the City pursuant to Government Code Section 65943, or for which a Notice of Preparation for a Draft Environmental Impact Report has been circulated or for which plans sufficient for a complete plan check were accepted by the Department of Building and Safety, on or before the effective date of this ordinance (03/31/1993).

**5. MONITORING**

The Department of Transportation shall be responsible for monitoring the owner/applicant's continual implementation and maintenance of the project trip reduction features required by this ordinance.

**6. ENFORCEMENT**

Applicants shall execute and record a Covenant and Agreement that the trip reduction features required by this ordinance will be maintained, that required material specified in Subdivision 3 (a) (1)-(5) will be continually posted, and that additional carpool/vanpool spaces within the designated preferential area will be signed and striped for the use of ridesharing employees based on demand for such spaces. The Covenant and Agreement shall be acceptable to the Department of Transportation.

**7. HARDSHIP EXEMPTION**

In cases of extreme hardship, duly established to its satisfaction, the City Council, acting in its legislative capacity, and by resolution, may grant an exemption from any/or all the provisions of this ordinance. In granting such an exemption, the City Council shall make the following findings:

- (a) Specific features of the development make it infeasible to satisfy all of the provisions of this subsection; and
- (b) The applicant has committed to provide equivalent alternative measures to reduce vehicle trips.

**ATTACHMENT M**

**ORDINANCE NO. 180542**

An ordinance adding a new Section 19.15 to the Los Angeles Municipal Code relative to application fees to be paid to the Department of Transportation for the review and assessment of traffic study reports, condition clearance and permit issuance activities related to obtaining any environmental clearance for private development projects within the City of Los Angeles.

**THE PEOPLE OF THE CITY OF LOS ANGELES  
DO ORDAIN AS FOLLOWS:**

Section 1. Subdivision 6 of Subsection A of section 19.05 of the Los Angeles Municipal code is hereby repealed and Subdivisions 7, 8 and 9 thereof, are redesignated as Subdivisions 6, 7 and 8 respectively.

Sec. 2. A new Section 19.15 is added to the Los Angeles Municipal Code to read as follows:

**Sec. 19.15. DEPARTMENT OF TRANSPORTATION TRAFFIC STUDY REVIEW, CONDITION CLEARANCE AND PERMIT ISSUANCE FEES**

(a) The following specific fees shall be paid to the Department of Transportation for the preparation and processing of traffic reports, clearance of conditions and permit sign offs in connection with obtaining any environmental clearance and/or permit issuance related tasks.

(1)	Initial Site Assessment Form (ISAF) Issuance.....	\$ 434
(2)	Traffic Study MOU .....	\$1,143
(3)	Traffic Study Reviews (note 1).....	\$7,396
(4)	Site plan Reviews .....	\$1,789
(5)	Project Condition Clearance (note 2).....	\$ 256
(6)	Driveway Permit Sign-Offs.....	\$ 508
(7)	Building Permit Sign-Offs.....	\$ 354
(8)	Subdivision Reports.....	\$ 197
(9)	Dedication & Widening Waivers .....	\$ 764
(10)	Street Vacation Requests .....	\$1,910

---

*Note 1: \$7,396 for the first 10 study intersections plus \$400 per each additional study intersection, not to exceed a total of \$25,000.*

*Note 2: \$256 for the first 3 condition clearances plus \$200 for each additional condition clearance.*

---

**(b) TRANSPORTATION REVIEW FEE FUND**

A Transportation Review Fee Fund is hereby established into which two percent (2%) of the fees collected pursuant to this Section shall be

deposited. This fund shall be used exclusively by the Department of Transportation to provide funding for the continual enhancement of development review-related information technology systems, including procurement costs associated with equipment, materials and consulting services. Except as provided herein, all fees collected pursuant to this Section shall be credited to the General Fund.

**(c) METHODS OF ADJUSTMENT OF FEES**

The Department of Transportation shall provide an annual review of the fees established pursuant to this Section, and shall submit recommendations for changes in these fees for special services to the Council, as follows:

- (1)** By May 1<sup>st</sup> of each odd numbered year, the Department shall provide a comprehensive study of fees for services, and shall provide a report and proposed draft ordinance to the Mayor and the City Council detailing any requested changes in the fees for any special services enumerated in this Section. The comprehensive study shall include: 1) measurement of the average salary increase in effect for all Transportation Planning (TP) staff members from the previous calendar year; 2) measurement of changes in material, equipment and contract costs related to any and all fee-for-service items; 3) adjustment of any changes required in the amount of personnel time necessary to complete any service tasks; and 4) current indirect costs for labor provided by the City's Cost Allocation Plan. Cost figures shall be compared to the current baseline established for each fee. Recommended fee changes shall be rounded to the nearest whole dollar. The recommended fee changes shall be requested to take effect beginning July 1<sup>st</sup> of the reporting year.
- (2)** By May 1<sup>st</sup> of each even numbered year, the Department shall provide a proposal for the adjustment of fees for services, and shall provide a report and proposed draft ordinance to the Mayor and the City Council detailing any requested changes in the fees for any service enumerated in this Section. The adjustment shall include a measurement of the average salary increase in effect for all TP staff members from the previous calendar year. Current indirect costs for labor from the City's Cost Allocation Plan shall also be included as part of the adjustment and assessment report. Cost figures shall be compared to the current baseline established for each fee. Recommended fee changes shall be rounded to the nearest whole dollar. The recommended fee changes shall be requested to take effect beginning July 1<sup>st</sup> of the reporting year.

Sec. 3. The City Clerk shall certify to the passage of this ordinance and have it published in accordance with Council policy, either in a daily newspaper circulated in the City of Los Angeles or by posting for ten days in three public places in the City of Los Angeles: one copy on the bulletin board located at the Main Street entrance to the Los Angeles City Hall; one copy on the bulletin board located at the Main Street entrance to the Los Angeles City Hall East; and one copy on the bulletin board located at the Temple Street entrance to the Los Angeles County Hall of Records.

I hereby certify that this ordinance was passed by the Council of the City of Los Angeles, at its meeting of FEB 10 2009.

KAREN E. KALFAYAN, City Clerk

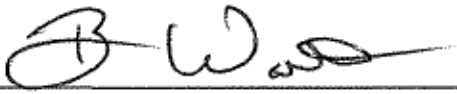
By  Deputy

Approved FEB 18 2009

 Mayor

Approved as to Form and Legality

ROCKARD J. DELGADILLO, City Attorney

By   
SHELLEY J. SMITH  
Assistant City Attorney

Date 10/21/08

File No. CF 08-2268