

EFF- 6/8/2016

ORDINANCE NO. 184268

An ordinance establishing the Sylmar Community Plan Implementation Overlay (CPIO) District for the Sylmar Community Plan area.

**THE PEOPLE OF THE CITY OF LOS ANGELES
DO ORDAIN AS FOLLOWS:**

Section 1. Pursuant to Section 13.14 of the Los Angeles Municipal Code (LAMC), the City Council hereby establishes and adopts the attached Sylmar CPIO District. The Sylmar CPIO District's boundaries are identical to the boundaries of the Sylmar Community Plan, adopted on June 10, 2015 (Council File No. 15-0622).

Sec. 2. The City Clerk shall certify to the passage of this ordinance and have it published in accordance with Council policy, either in a daily newspaper circulated in the City of Los Angeles or by posting for ten days in three public places in the City of Los Angeles: one copy on the bulletin board located at the Main Street entrance to the Los Angeles City Hall; one copy on the bulletin board located at the Main Street entrance to the Los Angeles City Hall East; and one copy on the bulletin board located at the Temple Street entrance to the Los Angeles County Hall of Records.

I hereby certify that this ordinance was passed by the Council of the City of Los Angeles, at its meeting of APR 20 2016.

HOLLY L. WOLCOTT, City Clerk

By  _____ Deputy

Approved 4/28/16 _____

 _____ Mayor

Approved as to Form and Legality

MICHAEL N. FEUER, City Attorney

By  _____
MICHAEL J. BOSTROM
Deputy City Attorney

Pursuant to Charter Section 559, I approve this ordinance on behalf of the City Planning Commission and recommend that it be adopted

Date 2/19/16 _____

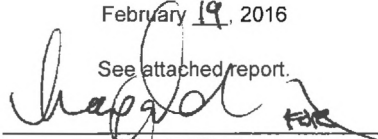
February 19, 2016
See attached report.
 _____
Vincent Bertoni
Director of Planning

File No. 15-0622

DECLARATION OF POSTING ORDINANCE

I, JUAN VERANO, state as follows: I am, and was at all times hereinafter mentioned, a resident of the State of California, over the age of eighteen years, and a Deputy City Clerk of the City of Los Angeles, California.

Ordinance No. 184268 – Establishing the Sylmar Community Plan Implementation Overlay District for the Sylmar Community Plan area – a copy of which is hereto attached, was finally adopted by the Los Angeles City Council on **April 20, 2016**, and under the direction of said City Council and the City Clerk, pursuant to Section 251 of the Charter of the City of Los Angeles and Ordinance No. 172959, on **April 29, 2016** I posted a true copy of said ordinance at each of the three public places located in the City of Los Angeles, California, as follows: 1) one copy on the bulletin board located at the Main Street entrance to the Los Angeles City Hall; 2) one copy on the bulletin board located at the Main Street entrance to the Los Angeles City Hall East; 3) one copy on the bulletin board located at the Temple Street entrance to the Los Angeles County Hall of Records.

Copies of said ordinance were posted conspicuously beginning on **April 29, 2016** and will be continuously posted for ten or more days.

I declare under penalty of perjury that the foregoing is true and correct.

Signed this **29th** day of **April 2016** at Los Angeles, California.

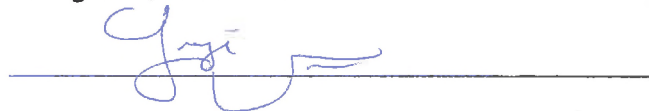

Juan Verano, Deputy City Clerk

Ordinance Effective Date: June 8, 2016

Council File No. 15-0622

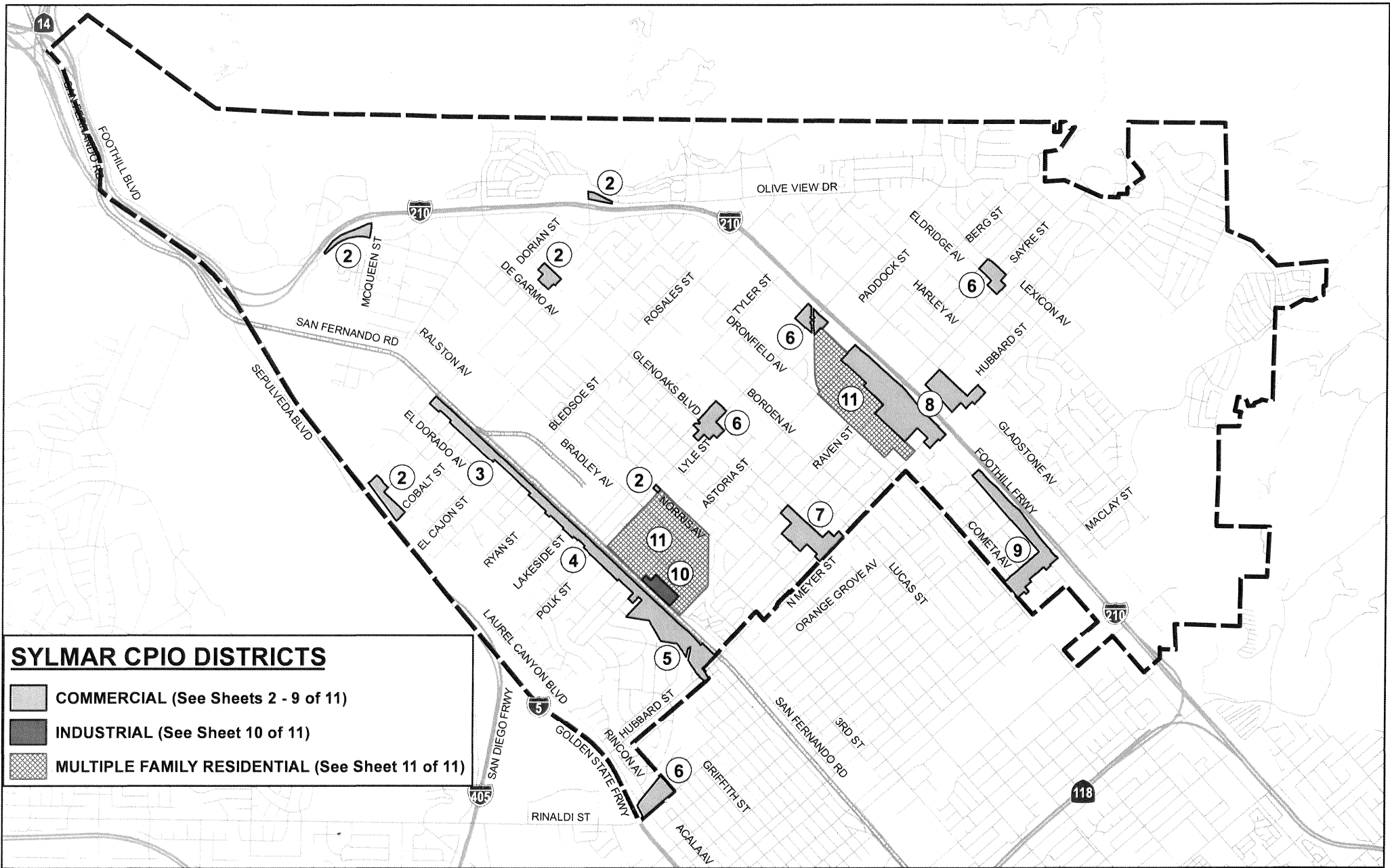

**Sylmar Community Plan Area
 CPIO - Community Plan Implementation Overlay**

(Sheet 1 of 11)

Sylmar Community Plan Area

See Sheet Number for Details

Data Sources: Department of City Planning, Bureau of Engineering

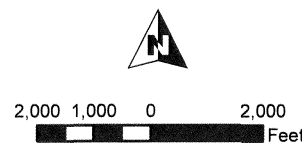

CPC-2006-5569-CPU

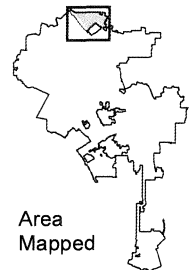
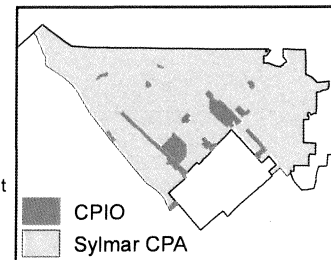

Area Mapped

042815 CF/lla

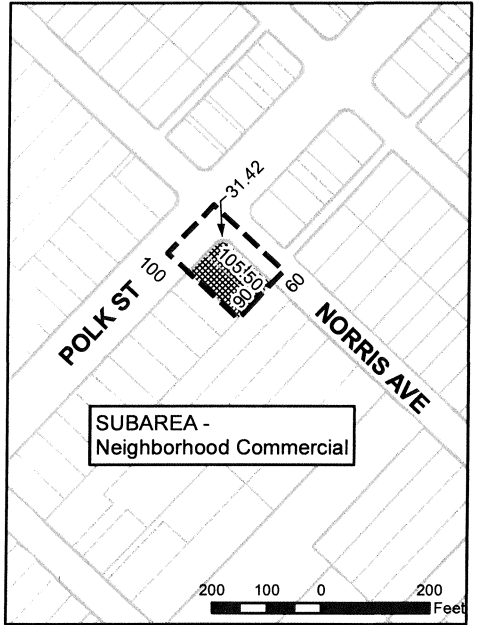
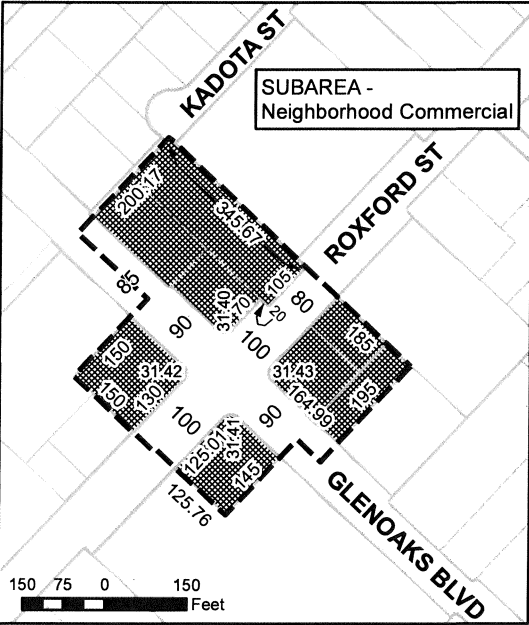
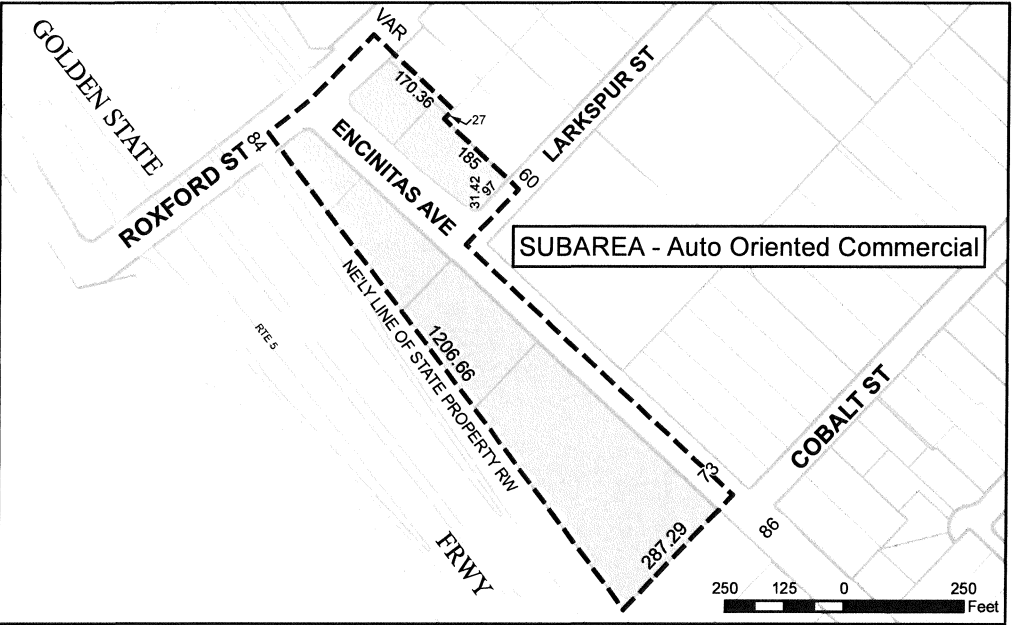
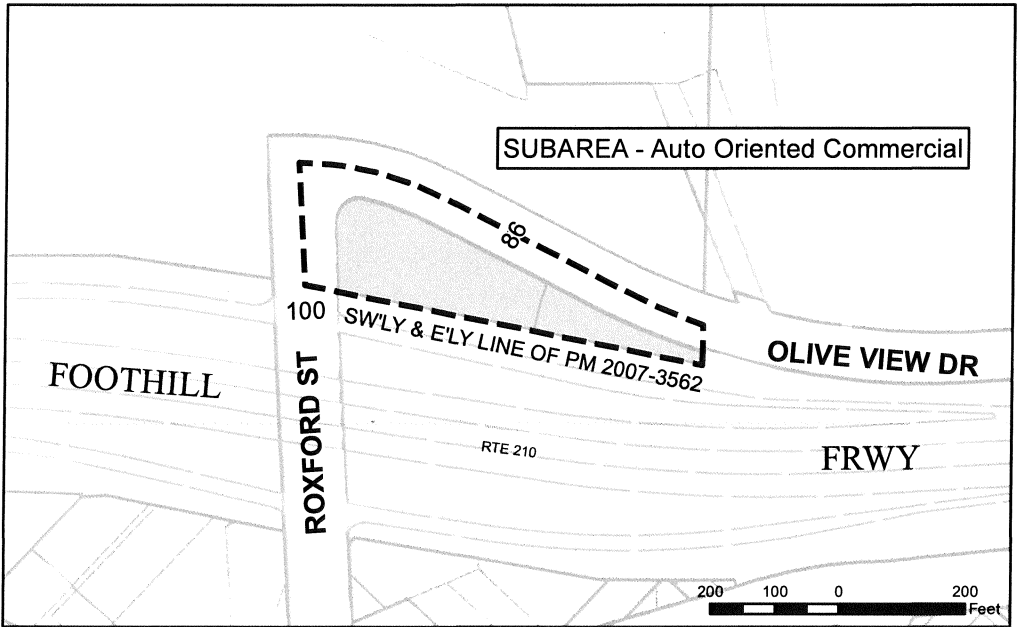
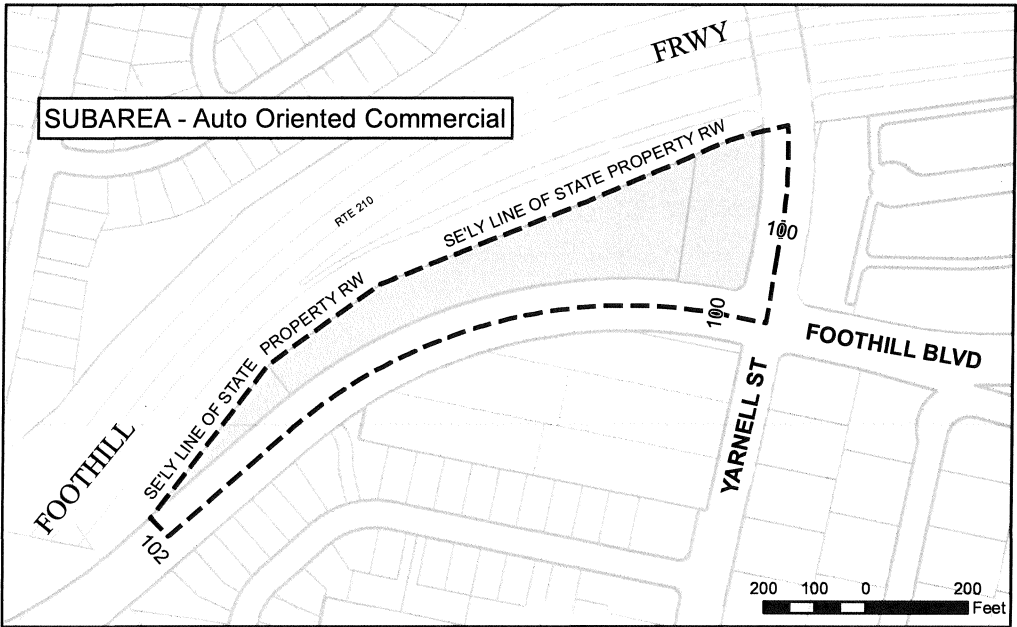

**Sylmar Community Plan Area
CPIO - Community Plan Implementation Overlay
District - COMMERCIAL**

(Sheet 2 of 11)

[Dashed Line] Commercial District Boundary



C.M. 228 B 141, 228 B 145, 228 B 149
222 B 141, 222 B 149, 219 B 141 CPC-2006-5569-CPU

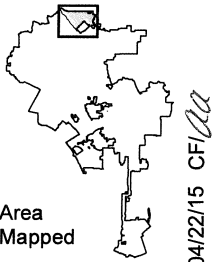
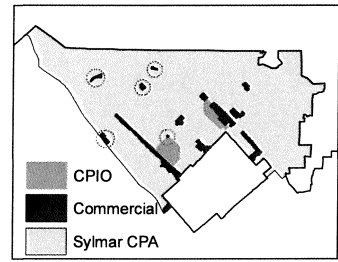

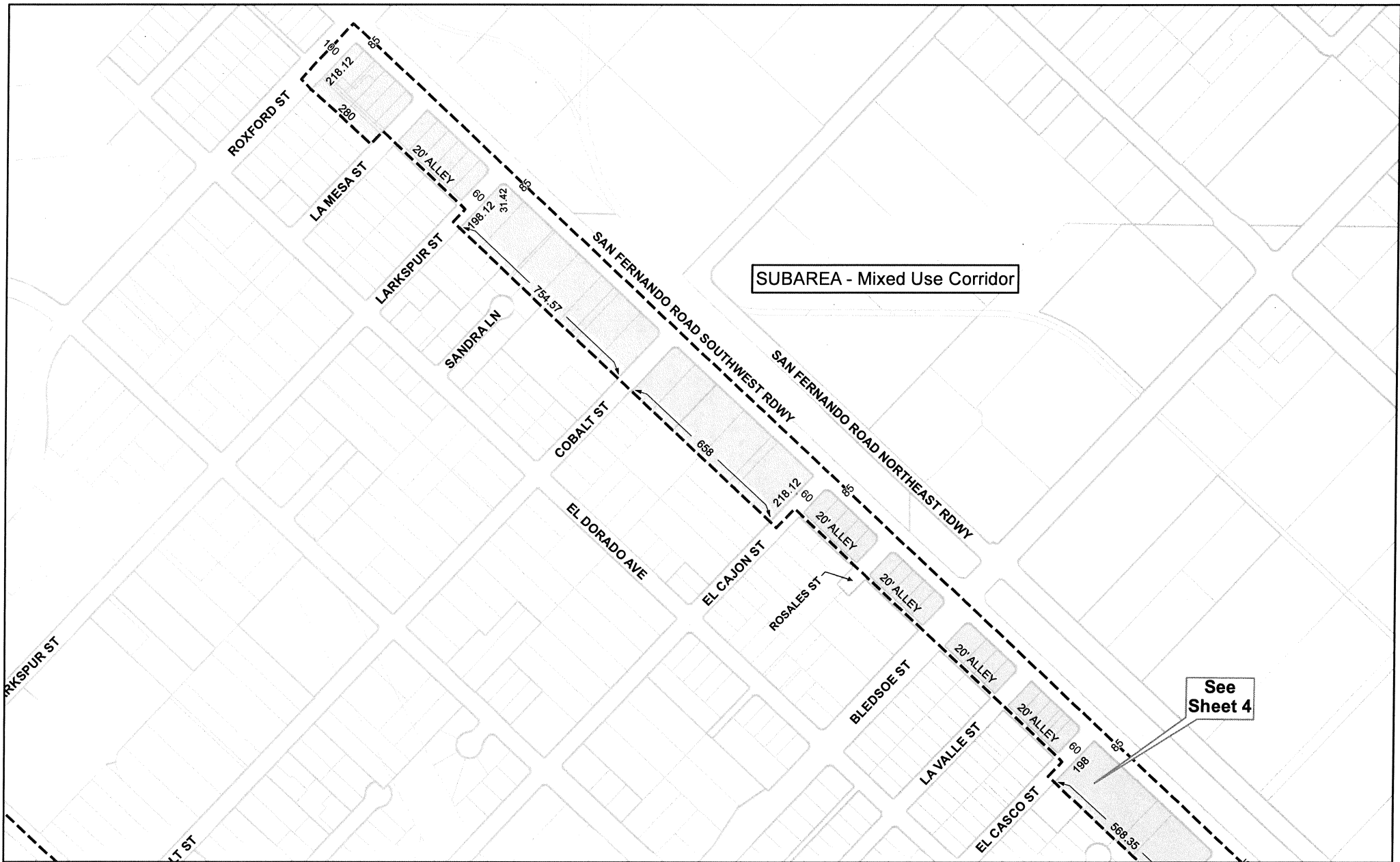

**Sylmar Community Plan Area
CPIO - Community Plan Implementation Overlay
District - COMMERCIAL**

(Sheet 3 of 11)

Commercial District Boundary

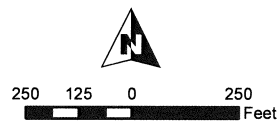

C.M. 225 B 141, 222 B 141, 222 B 145 CPC-2006-5569-CPU

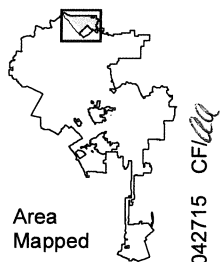
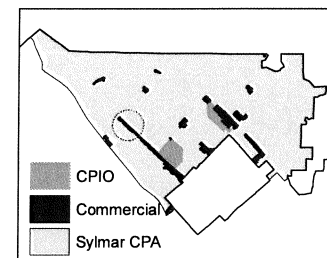

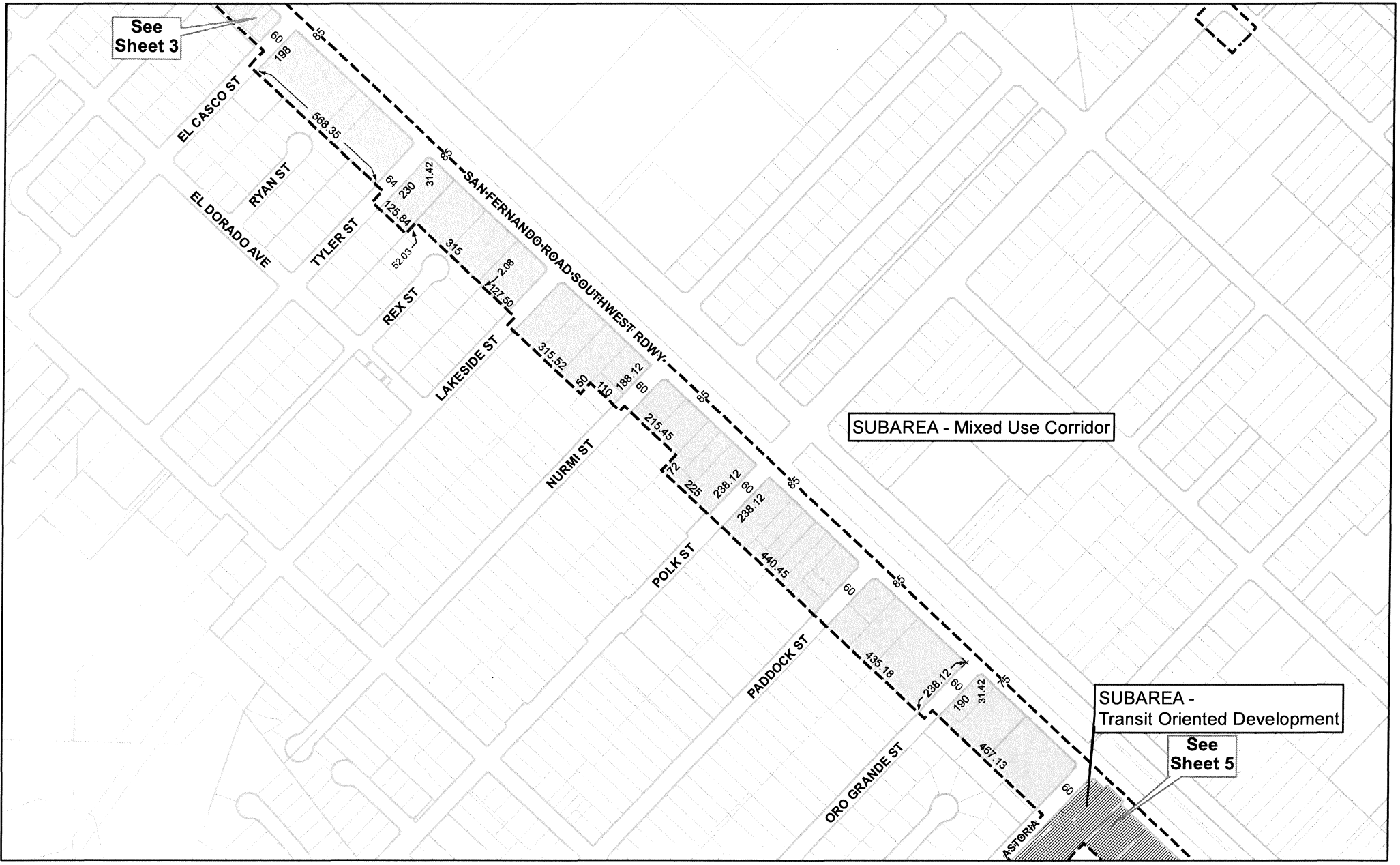

**Sylmar Community Plan Area
CPIO - Community Plan Implementation Overlay
District - COMMERCIAL**

(Sheet 4 of 11)

Commercial District Boundary

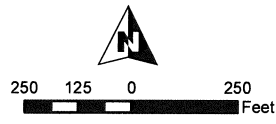

C.M. 222 B 145, 219 B 145, 219 B 149 CPC-2006-5569-CPU

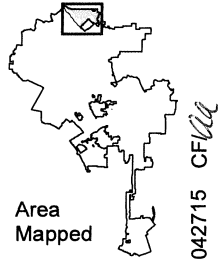
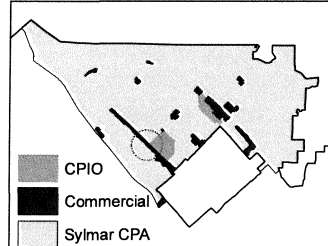

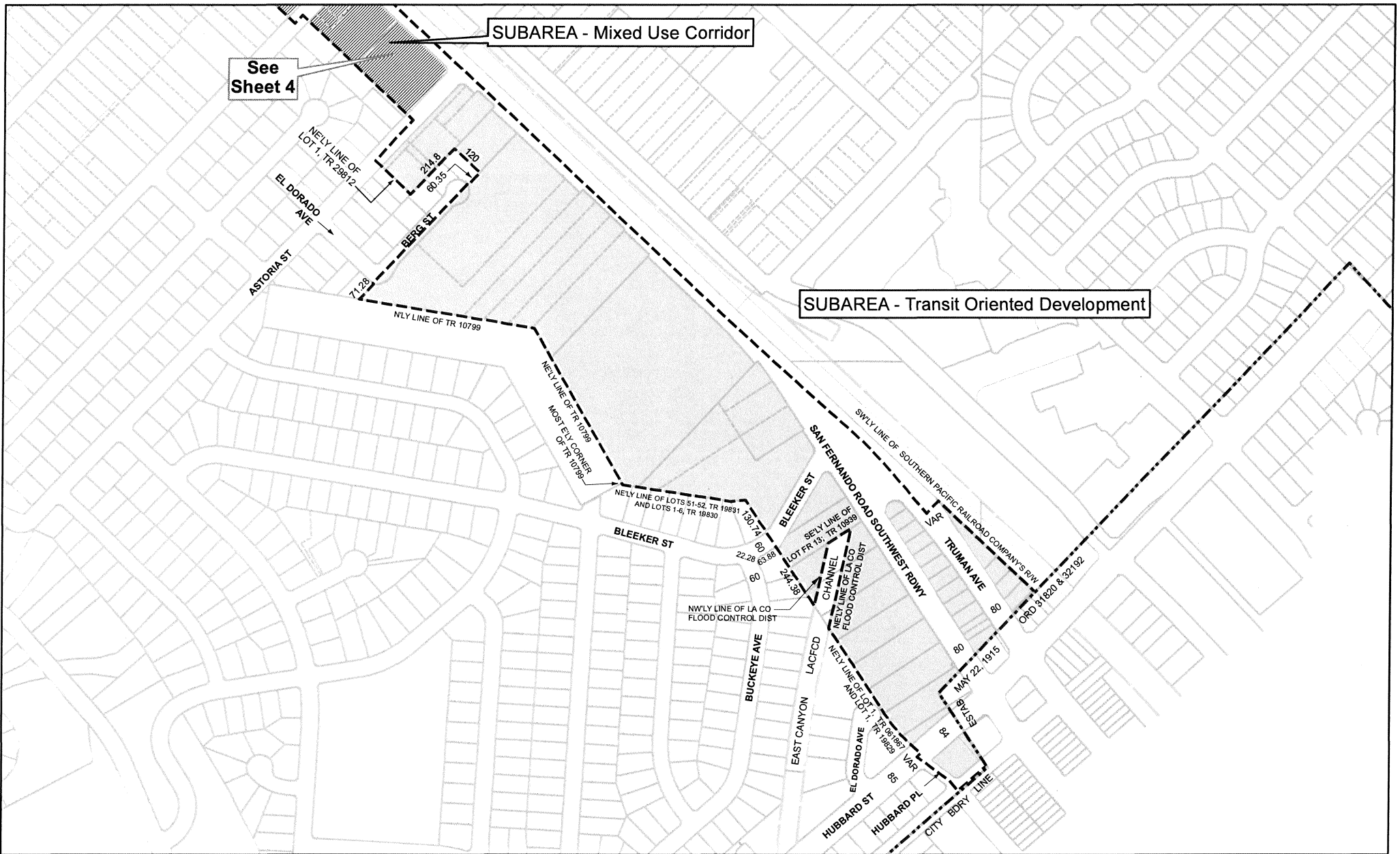

See Sheet 4

SUBAREA - Mixed Use Corridor

SUBAREA - Transit Oriented Development

**Sylmar Community Plan Area
CPIO - Community Plan Implementation Overlay
District - COMMERCIAL**

(Sheet 5 of 11)

Commercial District Boundary

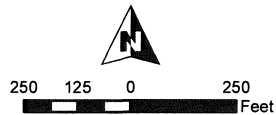

C.M. 219 B 149, 216 B 149 CPC-2006-5569-CPU

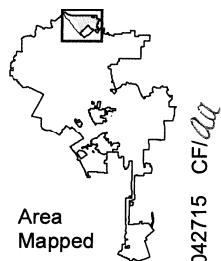
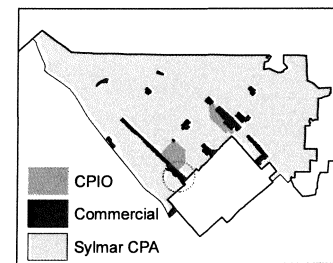

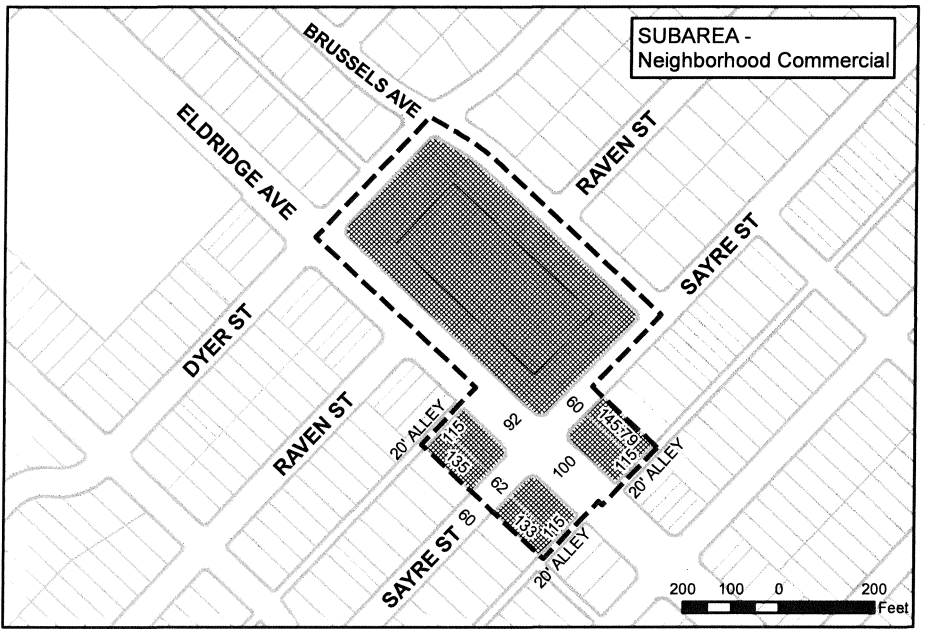
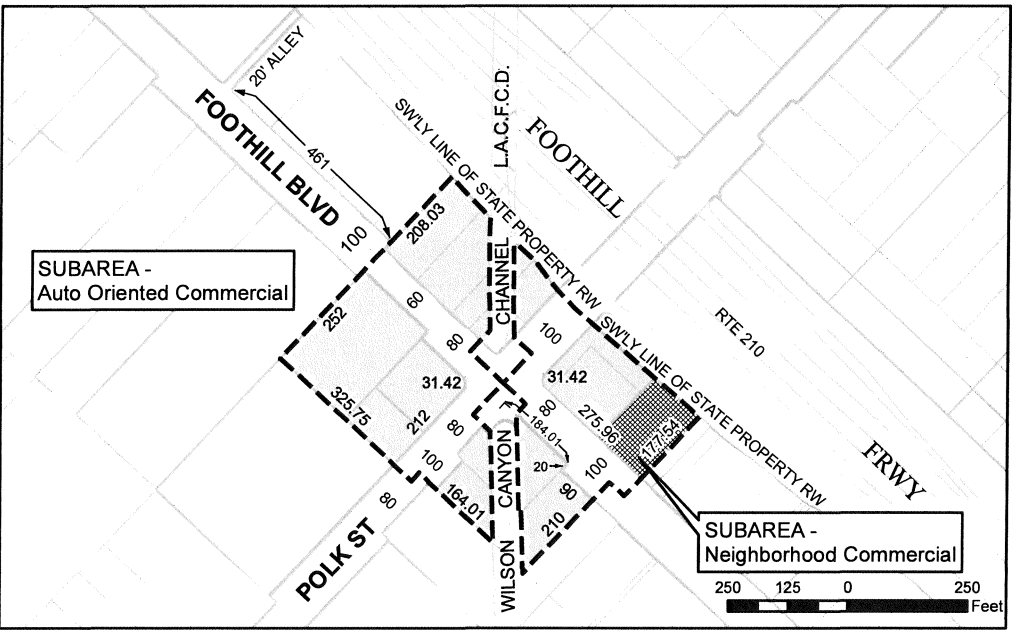
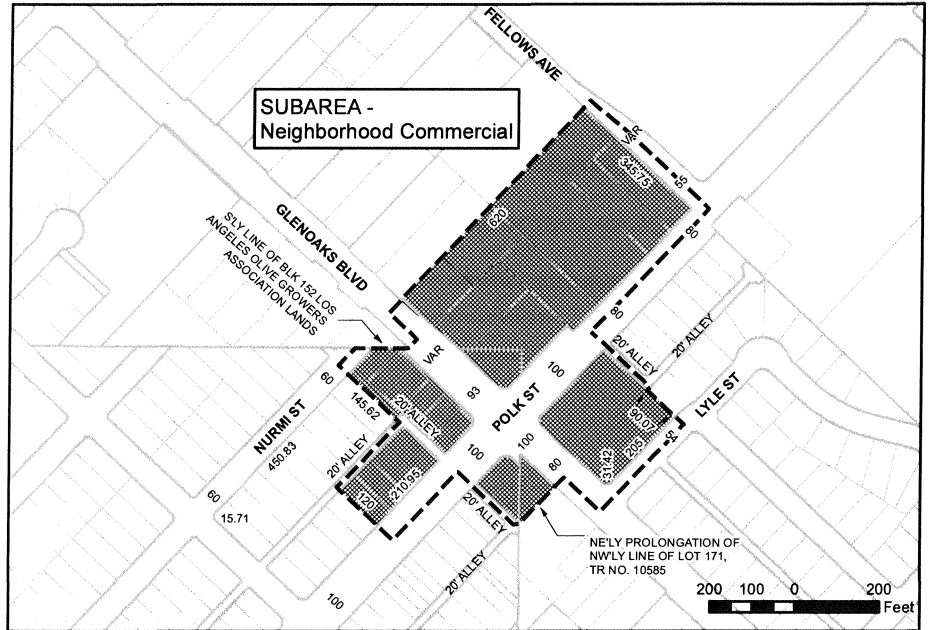
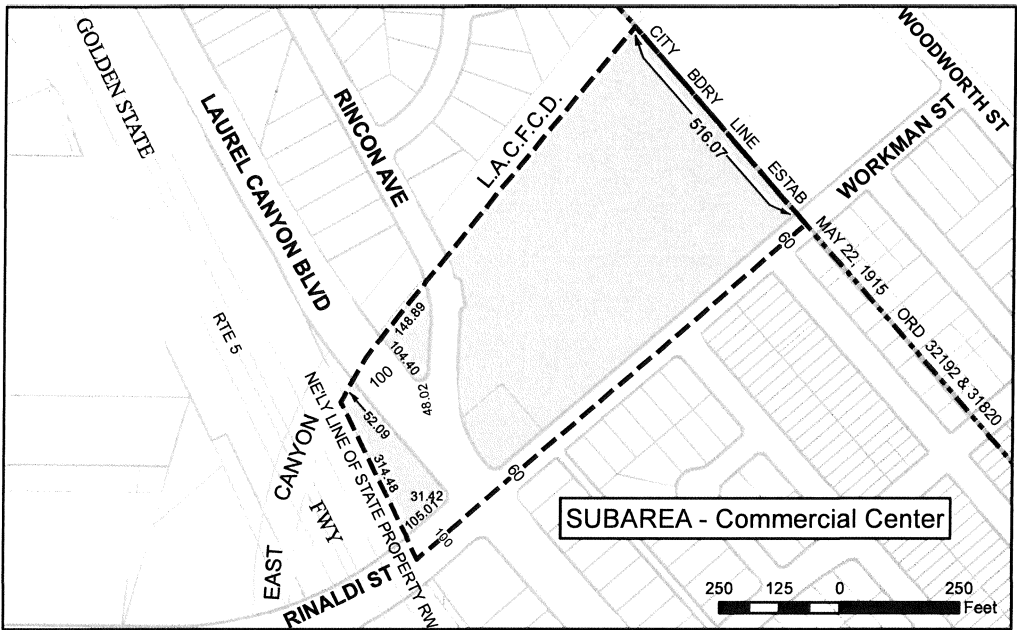

**Sylmar Community Plan Area
CPIO - Community Plan Implementation Overlay
District - COMMERCIAL**

(Sheet 6 of 11)

Commercial District Boundary



C.M. 213 B 149, 222 B 149, 225 B 149
225 B 153, 225 B 157, 228 B 157 CPC-2006-5569-CPU

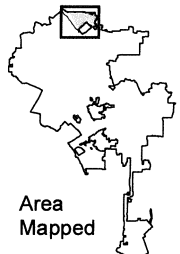
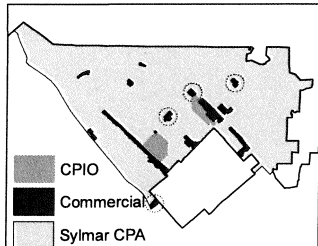

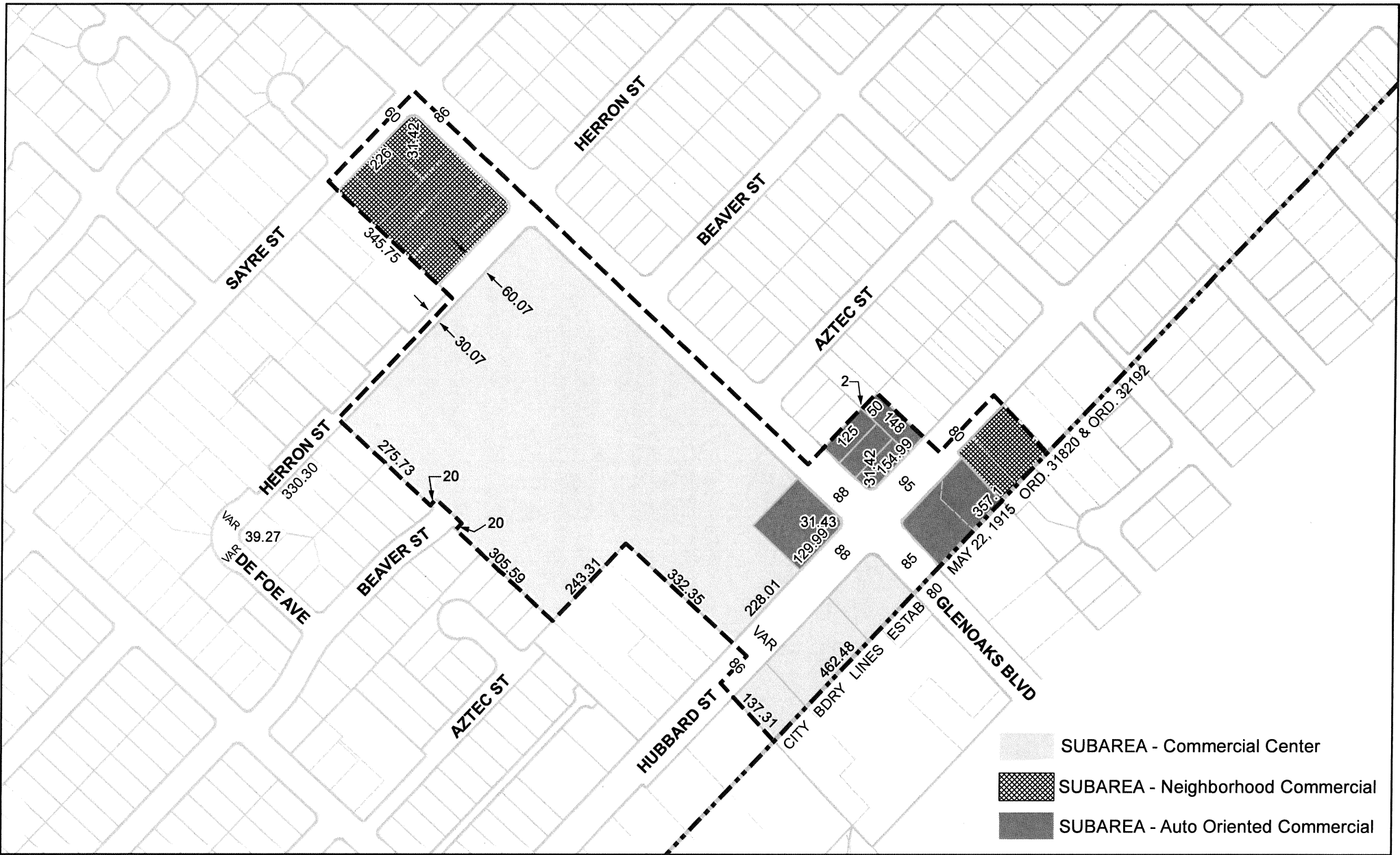

**Sylmar Community Plan Area
CPIO - Community Plan Implementation Overlay
District - COMMERCIAL**

(Sheet 7 of 11)

Commercial District Boundary

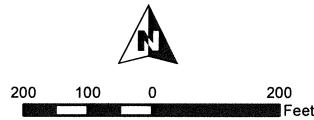

C.M. 222 B 153, 219 B 153 | CPC-2006-5569-CPU

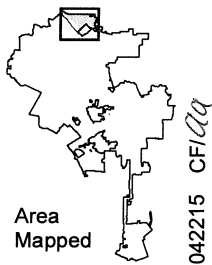
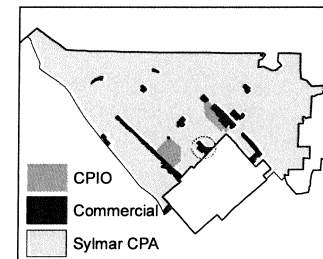



**Sylmar Community Plan Area
CPIO - Community Plan Implementation Overlay
District - COMMERCIAL**

(Sheet 8 of 11)

Commercial District Boundary

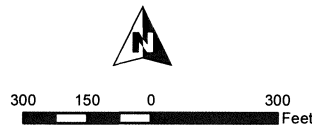

C.M. 222 B 153, 222 B 157 225 B 153, 225 B 157	CPC-2006-5569-CPU
---	-------------------

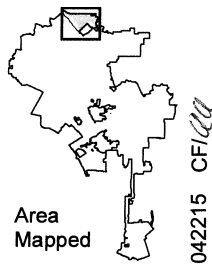
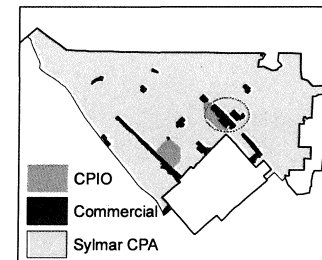



- SUBAREA - Commercial Only
- SUBAREA - Mixed Use Corridor
- SUBAREA - Auto Oriented Commercial

**Sylmar Community Plan Area
CPIO - Community Plan Implementation Overlay
District - COMMERCIAL**

Commercial District Boundary

(Sheet 9 of 11)

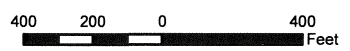

C.M. 219 B 157, 219 B 161 222 B 157	CPC-2006-5569-CPU
--	-------------------

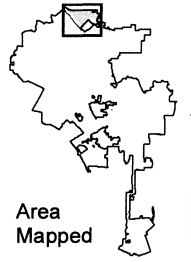
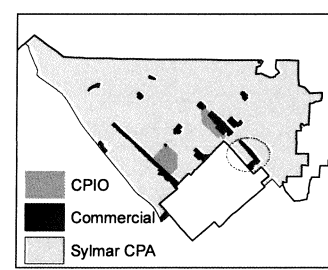



Sylmar Community Plan Area
CPIO - Community Plan Implementation Overlay
District - INDUSTRIAL

(Sheet 10 of 11)

 Industrial District Boundary

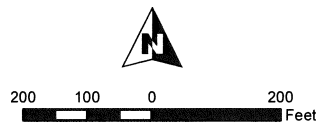

C.M. 219 B 149	CPC-2006-5569-CPU
----------------	-------------------

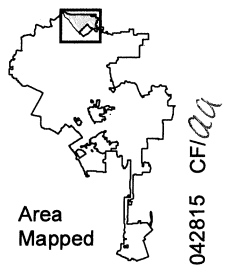
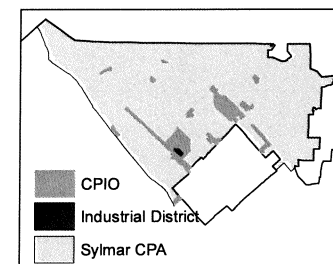

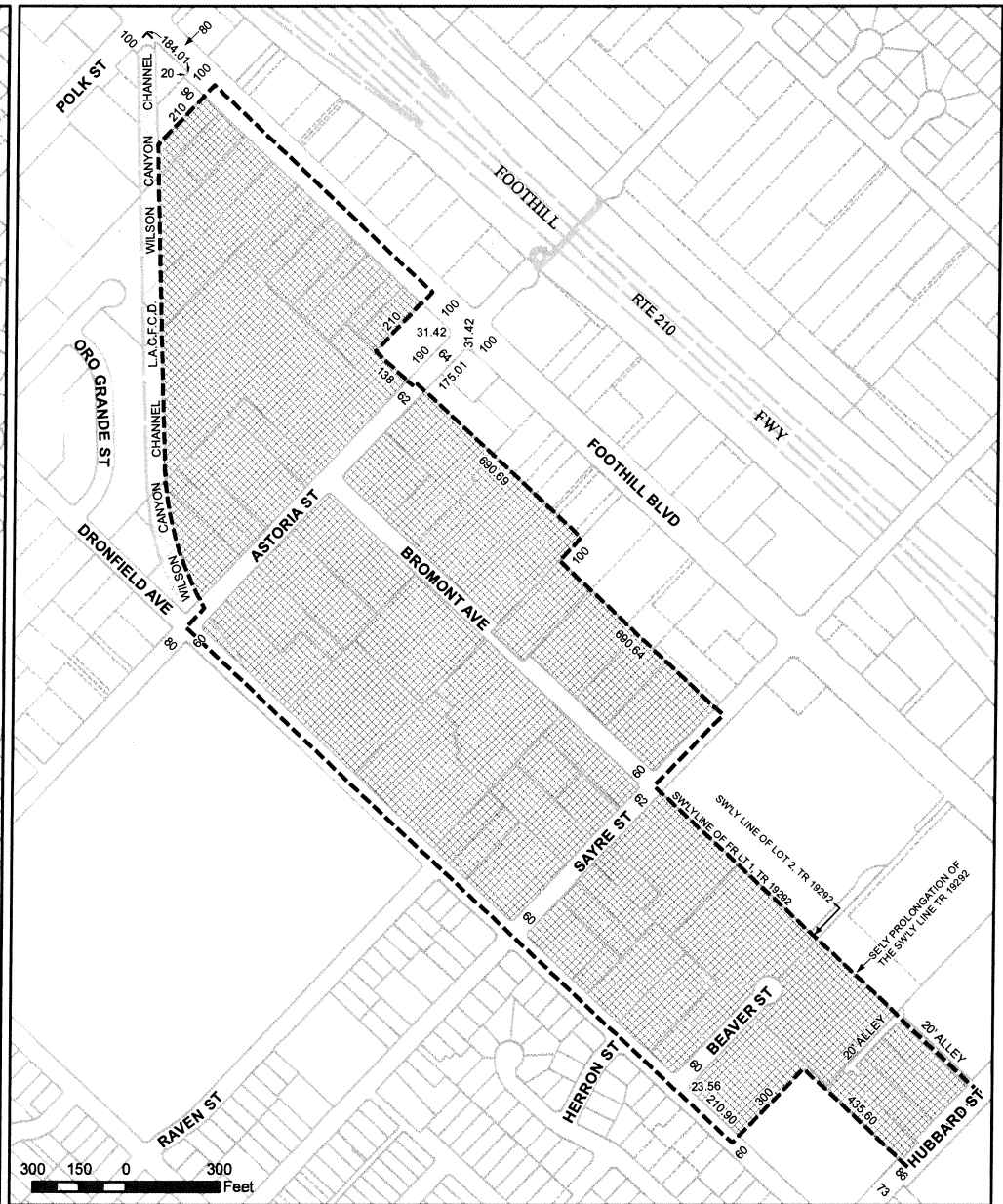
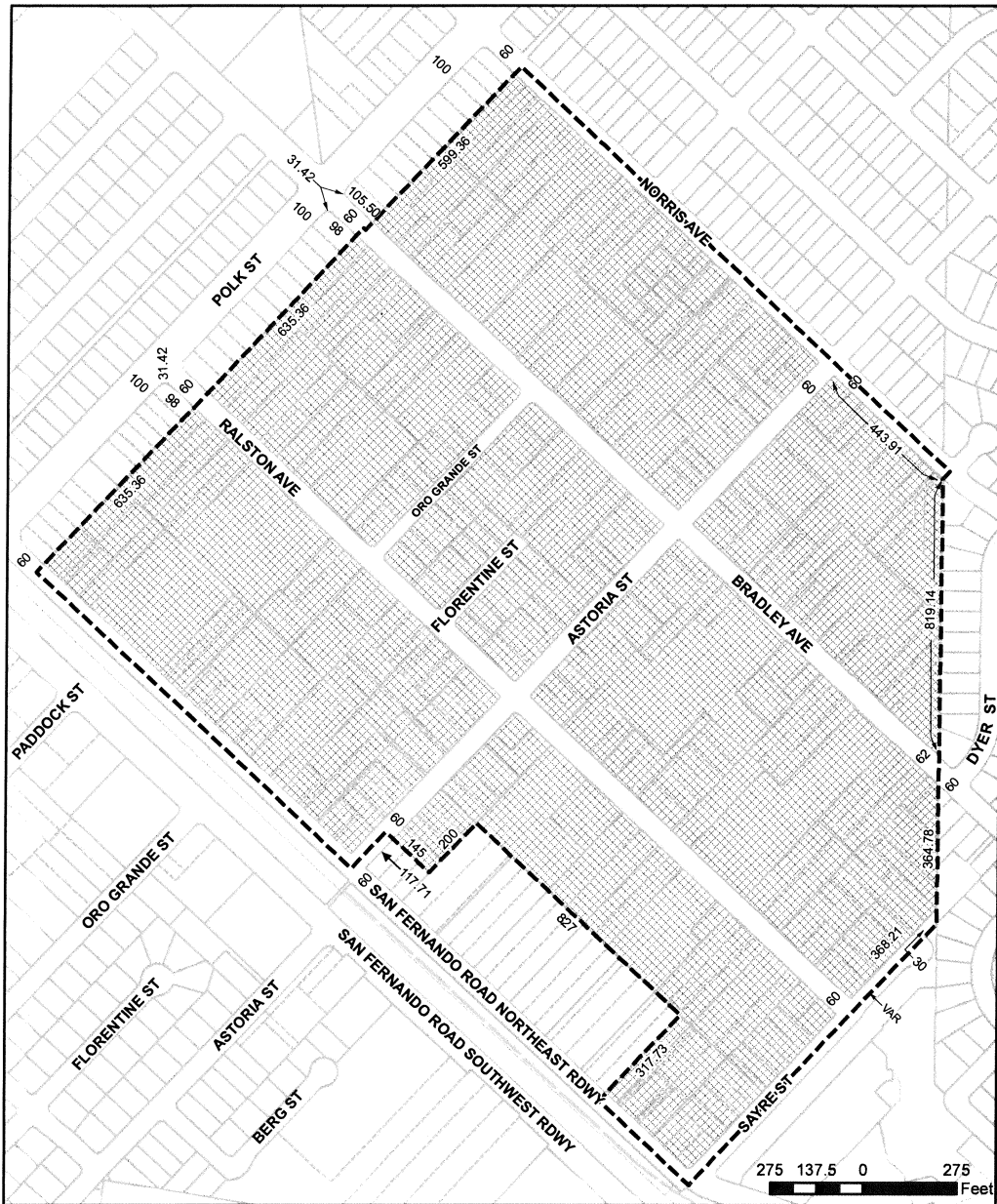

**Sylmar Community Plan Area
CPIO - Community Plan Implementation Overlay
District - MULTIPLE FAMILY RESIDENTIAL**

(Sheet 11 of 11)

Multiple Family Residential District Boundary



C.M. 225 B 153, 222 B 153, 222 B 157
222 B 149, 219 B 149

CPC-2006-5569-CPU

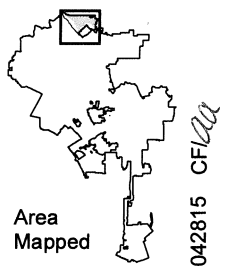
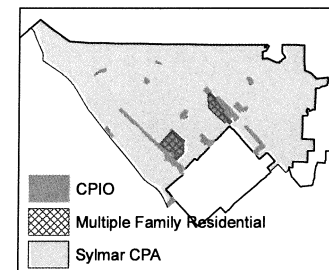

**Sylmar Community Plan Implementation
Overlay District**

TABLE OF CONTENTS

Chapter I	Function of the CPIO District
	Section 1. The Sylmar CPIO District Boundaries
	Section 2. Purpose
	Section 3. Definitions
	Section 4. General Prohibition on Issuance of Permits
	Section 5. Delegation of Administrative Clearance
	Section 6. Exclusions
	Section 7. Review Procedures
	Section 8. Environmental Standards Procedures
	Section 9. Severability
Chapter II	Commercial Subareas
	Section 1. Land Use Regulations
	Section 2. Development Standards
Chapter III	Industrial Subarea
	Section 1. Development Standards
Chapter IV	Multiple Family Residential Subarea
	Section 1. Development Standards
Appendix A	Design Guidelines
Appendix B	Environmental Standards

SECTION 1: THE SYLMAR CPIO DISTRICT BOUNDARIES

The Sylmar CPIO District boundaries are identical to the boundaries of the Sylmar Community Plan Area as adopted on June 10, 2015 (Council File No. 15-0622). This Sylmar CPIO District contains several Subareas as shown precisely by the solid boundary lines on the CPIO District Boundaries Maps (Maps 1 through 11) attached hereto and as depicted in Figure I below.



SECTION 2: PURPOSE

The Sylmar CPIO District provides Supplemental Development Regulations tailored to ensure that development enhances the unique architectural, environmental, and cultural qualities of the Sylmar Community Plan area, integrates improvements and enhancements to the public rights-of-way, and maintains compatible land uses, and appropriate development scale, intensity, and density. The Sylmar CPIO District also creates an Administrative Clearance (i.e., ministerial approval) process that enables infill development that will positively impact communities in conformance with these regulations.

The Sylmar CPIO District establishes eight CPIO Subareas that are contiguous or non-contiguous parcels characterized by common Community Plan goals, themes, and policies, and grouped by a common boundary. These eight subareas fall into three categories: the Commercial District, which contains six commercial subareas, a single Industrial subarea, and a single Multiple Family Residential subarea. The eight CPIO Subareas are briefly summarized below.

The Commercial District (Commercial Subareas A, B, C, D, E, and F)

The Commercial District includes six subareas as depicted in Figure II. The Commercial District is intended to protect parcels designated for commercial use by encouraging new development and economic reinvestment according to each subarea type and its corresponding Supplemental Development Regulations, in order to provide a wider range of goods and services, to reduce potential land use conflicts, and increase employment opportunities in the City. The Commercial District is intended to encourage improved design and orientation of new commercial development in a manner compatible with the goals of the Community Plan. The six subareas are summarized as follows:

Subarea A: Neighborhood Commercial. This subarea serves as a focal point for surrounding residential neighborhoods and contains land uses that serve the daily needs of nearby residents and employees. The goal is for new development to be designed at a pedestrian scale so that services and amenities are convenient, visually pleasing, and properly integrated and designed to encourage walking, cycling, horseback riding and other forms of active transportation. Typical uses include, but are not limited to, barber shops, bakeries, coffee shops, florists, food and grocery stores, and restaurants. Auto-related uses are expressly prohibited.

Subarea B: Commercial Only. This subarea is intended to accommodate a variety of commercial uses. A mix of retail and services of larger scale and format than those permitted in the Neighborhood Commercial subarea are encouraged. Residential uses, including live-work units, are prohibited, as are auto related uses.

Subarea C: Auto-Related Commercial. This subarea allows a wider range of commercial uses than in Subareas A and B. Auto-related uses are allowed in this subarea in order to reduce the proliferation of these uses along the other commercial corridors.

Subarea D: Commercial Center. This subarea promotes vibrant and attractive destination points for civic, cultural, economic, and entertainment life for the adjoining

neighborhoods and the greater community. Commercial Centers are intended to be comprised of medium-scale projects and residential uses are generally permitted subject to certain restrictions.

Subarea E: Mixed-Use Corridor. This subarea allows for a gradual development of mixed-use, moderate-density residential and commercial areas where people can enjoy walking, shopping, working, and living. This subarea is intended to allow for select commercial uses and residential development in a manner that serves the needs of the surrounding neighborhoods and enhances the appearance and identity of San Fernando Road and Maclay Street. New auto-related uses are expressly prohibited.

Subarea F: Transit-Oriented Development (TOD). This subarea is intended to allow development that is transit-supportive and pedestrian-oriented within walking distance of the Sylmar/San Fernando Metrolink Station. This subarea is intended to accommodate moderate- to high-density, mixed-use development, while improving the aesthetic quality of architecture and encouraging a mix of uses in proximity to the station and one another. New auto-related/oriented uses are expressly prohibited.

Industrial Subarea G

Subarea G: Industrial. The Industrial subarea boundaries are comprised of a single subarea as depicted in Figure III. The Industrial Subarea preserves existing industrial properties within this area and provides Supplemental Development Regulations that are intended to ensure that new development will be compatible with adjacent residential uses.

Multiple Family Residential Subarea H

Subarea H: Multiple Family Residential. The Multiple Family Residential subarea boundaries are comprised of a single subarea as depicted in Figure IV. The Multiple Family Residential Subarea is intended to bring increased stability to residential neighborhoods by introducing new Supplemental Development Regulations that encourage new infill development that is consistent with the overall character of the area.

SECTION 3: DEFINITIONS

Whenever the following terms are used in this ordinance, they shall be construed as defined in this Chapter 1, Section 3. Words or phrases not defined here shall be construed as defined in Section 12.03 of the LAMC.

Administrative Clearance – A ministerial approval for a Project in a Sylmar CPIO Subarea that is obtained pursuant to Section 13.14 G.2 of the LAMC.

Architectural Treatment – An aesthetic element of a building’s design that is integral to the overall style of architecture, but is not considered habitable, or otherwise counted as part of the building’s floor area.

Auto-Related Use – Any business used for an automotive use, as defined in the Los Municipal Code. In addition, Auto-Related Use shall include automobile and trailer sales areas, automotive repair establishments, automotive fueling and service stations,, or any other business used for the retail sale of new or used parts for motor vehicles and vessels. In addition, Auto-Related Use includes automobile laundry and wash racks, and drive-through establishments.

Drive-through Establishment – Any business used for the execution of a sale, or business transaction, to an individual in a motor vehicle.

Office Park – A development consisting primarily of professional office facilities where the permitted uses are planned, developed, managed and maintained as a unit, with common landscaping, amenities, and off-street parking to serve all the uses on the property.

Pedestrian Amenities – Any public or private improvement that facilitates direct, safe, attractive, accessible and enjoyable walking. This phrase includes outdoor sidewalk cafes, public plazas, retail courtyards, water features, kiosks, paseos, arcades, patios, covered walkways, or spaces of outdoor dining or seating that are located on the ground floor, and that are accessible to and available for use by the public.

Project – Any activity that requires the issuance of a building, demolition, grading, or change of use permit. A Project does not include construction that consists solely of interior rehabilitation/repair work.

Primary Frontage – The exterior building walls facing the Primary Lot Line. For the purposes of this definition, all exterior walls that intersect a plane parallel to a lot line at 45 degrees or less shall be considered the Primary Frontage. When the Primary Lot Line is not straight, a line connecting the points where the secondary or side lot lines and the Primary Lot Line intersect shall be used.

Primary Lot Line – The property line of a lot that is contiguous with a public street. On lots fronting more than one public street, the Director of Planning shall determine the Primary Lot Line based upon neighborhood characteristics, including the designation of the abutting streets and the dimensions of the subject lot.

SECTION 4: GENERAL PROHIBITION ON ISSUANCE OF PERMITS

The Department of Building and Safety shall not issue a permit for demolition, grading, construction, erection, addition to, or alteration of any building or structure, subdivision of land, a use of land, or change of use, unless an Administrative Clearance, a CPIO Adjustment, or CPIO Exception has been obtained pursuant to the applicable procedures in Section 13.14 G of the LAMC.

SECTION 5: DELEGATION OF ADMINISTRATIVE CLEARANCE

The Director of Planning may delegate the review of specific types of work that are eligible for an Administrative Clearance to the Department of Building and Safety, provided that such delegation has been made in writing.

SECTION 6: EXCLUSIONS

Any entitlements, or procedures, normally required by the LAMC, remain in effect within the CPIO, except for the following:

- The Mini-Shopping Center Commercial Corner Development Standards and Conditions of Operation set forth in LAMC Section 12.22 A.23 do not apply to lots within the CPIO.

SECTION 7: REVIEW PROCEDURES

1. **Applicability.** The following procedures governing Administrative Clearances, CPIO Adjustments, and CPIO Exceptions are in addition to the requirements set forth in Section 13.14 of the LAMC. They apply only to Projects within a Sylmar CPIO Subarea.
2. **Application for a CPIO Approval.** To apply for a CPIO approval, an applicant shall file an application with the Department of City Planning, on a form provided by the Department, and include all information required by the instructions on the application, and the guidelines adopted by the Director of Planning. The owner(s) of the property shall verify that all information in the application and related materials are true. The granting of a CPIO approval shall not imply, or be deemed to constitute, compliance with any other applicable provisions of the LAMC.
 - a. **Pre-Application Completion.** Prior to deeming the application complete, the Director shall determine and, if necessary, advise the applicant of the processes to be followed, materials to be submitted, and fees to be paid.
 - b. **Content of Application.** An applicant shall provide a set of detailed plans that demonstrate, in full, compliance with all applicable provisions of the particular Sylmar CPIO Subarea. In addition, those Projects that are eligible for Administrative Clearance, but require an additional discretionary action (e.g., Small Lot Subdivision, Site Plan Review, a Conditional Use, or a Zone Variance), shall still demonstrate, in full, on the detailed plans that the Project complies with all applicable provisions of the Sylmar CPIO Subarea when the

application for the discretionary action is submitted to the Department. Each application submitted for a CPIO Adjustment, or a CPIO Exception shall clearly identify and list all of the adjustments and/or exemptions requested as part of the Project.

- c. **Initial Decision.** The initial decision on an application shall be made as set forth in Section 13.14 of the LAMC after reviewing the Project for compliance with all applicable Supplemental Development Regulations.
 - d. **Procedures.** In addition to Section 13.14 of the LAMC, all Projects shall comply with the additional procedures set forth below for each type of CPIO approval.
3. **Administrative Clearance.** As authorized by Section 13.14 G.2 of the LAMC, the Director shall grant an Administrative Clearance after the Department has reviewed the Project and has determined that it is in compliance with all applicable provisions of the CPIO Subarea, the Design Guidelines for Residential Areas, if applicable, and that all required fees have been paid.
- a. **Limitations.**
 - 1. The Director shall not grant an Administrative Clearance for a land use that is prohibited under the applicable CPIO Subarea.
 - 2. An applicant, who is unable to qualify a Project for an Administrative Clearance, may request relief through the procedures set forth in Subsection 4 (CPIO Adjustment) and/or Subsection 5 (CPIO Exception) below.
 - 3. Only those regulations related to the proposed scope of construction shall be imposed on a Project. For example, a Project that consists exclusively of a change of use need not address the Development Standards at all, and a Project that involves alterations to a storefront, but does not propose changes to an existing surface parking lot, is not required to address regulations for surface parking lots.
 - 4. If the Project does not substantially comply with the Design Guidelines in Appendix A, the Director shall return the application to the applicant with suggested design corrections.
 - b. **CEQA.** The Department shall treat any request for relief, in the form of a CPIO Adjustment or CPIO Exception, as a discretionary action that requires an applicant to prepare an environmental analysis in accordance with CEQA.

4. **CPIO Adjustments.**

- a. **Approval.** The Director, or the Director's designee, has initial decision-making authority to grant a CPIO Adjustment pursuant to Section 13.14 G.3 of the LAMC.

- b. **Findings.** The Director's determination shall include all written findings required pursuant to Section 13.14 G.3 (b) for each specific adjustment that is requested.
 - i. The Director shall also prepare an additional written finding that demonstrates how the project substantially complies with the Design Guidelines contained in Appendix A.

5. **CPIO Exceptions.**

- a. **Approval.** The Area Planning Commission has initial decision-making authority to grant a CPIO Exception pursuant to Section 13.14 G.4 of the LAMC.
- b. **Findings.** The Area Planning Commission's determination shall include all written findings required pursuant to Section 13.14 G.4 (b) for each specific exception that is requested.
 - i. The Area Planning Commission will also prepare an additional written finding that demonstrates how the project substantially complies with the Design Guidelines contained in Appendix A.

SECTION 8: ENVIRONMENTAL STANDARDS PROCEDURES

An applicant seeking a CPIO approval in a CPIO Subarea shall comply with all applicable Environmental Standards as set forth in Appendix B. These Environmental Standards are included to implement the Mitigation & Monitoring Program that was adopted along with the Sylmar Community Plan update and the City of Los Angeles Sylmar Community Plan Environmental Impact Report (No. ENV-2006-5624-EIR) dated May 2015 and certified on June 10, 2015.

- 1. **Applicability of Environmental Standards.** The initial decision maker, shall determine the applicability of Environmental Standards to a Project when an application is submitted requesting a CPIO approval. Only those standards that apply to the construction or operations at issue shall be required. For example, a project that involves minor façade alterations to a commercial structure will not need to comply with Environmental Standards that address noise and vibration during grading activities.
- 2. **Plans.** Compliance with all applicable Environmental Standards listed in Appendix B shall be demonstrated on the plans as project features (that is, features that are physically built into the project such as an air filtration system), or as operational features listed on a sheet within the plans (that is, features that are carried out either during the construction of the project, or over the life of the project, such as monitoring of biological resources on site).

Modification of Environmental Standards. The initial decision maker may modify the Environmental Standards listed in Appendix B when the decision maker finds, based on substantial evidence, that either: (1) the Environmental Standard is

infeasible and the decision maker has adopted a new equally effective measure and the new measure will not result in any new significant impacts; or (2) the Environmental Standard is no longer necessary to mitigate the impact. Modification of Environmental Standards may not be approved as part of an administrative clearance. Furthermore, any modification shall be reflected in the Project's environmental clearance.

SECTION 9: SEVERABILITY

If any provision of this Sylmar CPIO District or the application of the provision to any person, property or circumstances, is held invalid, the remainder of this Sylmar CPIO District or the application or the provisions to other persons, property or circumstances shall not be affected.

OVERVIEW

The intent of these Supplemental Development Regulations is to reduce any potential impacts from future development within the Sylmar CPIO Subarea on the surrounding environment. Projects, within a commercial subarea (see Figure II), shall comply with the applicable Supplemental Development Regulations in this Chapter II. (Note: Each subarea may also be referenced by its letter (e.g., “Auto Related Commercial” may also be referenced as “Subarea C”).)



SECTION 1: LAND USE REGULATIONS

A. Land Use Regulations

1. For a new use of land or any change of use, a Project shall comply with the land use regulations in Table I and Table II below.
2. For the maintenance and expansion of an existing use, made legally non-conforming by this Sylmar CPIO District, an applicant shall comply with LAMC Section 12.23.

Table I—Land Use Regulations	
General Use	Limitations
Auto-Related Use	This use is allowed only in Subarea C (Auto Related Commercial).
Commercial Uses	Subarea A (Neighborhood Commercial) is limited to C1 uses and the following: bicycle sales and repair; child care facilities; household electronics sales and repair.
Office Park	This use is allowed only in Subareas B (Commercial Only) and D (Commercial Center).
Outdoor/Open Storage	This use is prohibited in all subareas.
Outdoor Swap Meets	This use is prohibited in all subareas.
Dwelling Units	Prohibited in Subareas A (Neighborhood Commercial), B (Commercial Only), C (Auto Related Commercial), and portions of D (Commercial Center). In Subarea D (Commercial Center), dwelling units are prohibited on the north side of Foothill Boulevard between Sayre and Hubbard Street.

Table II—Ground Floor Commercial Use Limitations	
Subareas	Limitations
D: Commercial Center	<p>This subarea is required to provide ground-floor commercial uses along a Primary Frontage, at a minimum depth of 25 feet or the entire depth of the building (whichever is less), for a minimum of 75% of the length of the Primary Frontage, excluding any area used for pedestrian and vehicular circulation.</p> <p>In addition, dwelling units are limited to upper floors above non-residential uses, or behind non-residential uses that are at least 25 feet in depth.</p>
E: Mixed-Use Corridor	<p>Applicable only to corner lots, this subarea is required to provide ground-floor commercial uses along a Primary Frontage, at a minimum depth of 25 feet or the entire depth of the building (whichever is less), for a minimum of 75% of the length of the Primary Frontage, excluding area used for pedestrian and vehicular circulation.</p> <p>In addition, dwelling units are limited to upper floors above non-residential uses, or behind non-residential uses that are at least 25 feet in depth on</p>

	corner lots. Dwelling units are allowed on the ground floor on non-corner lots; however, single-family, duplex, and small lot subdivision projects are prohibited.
F: Transit-Oriented Development (TOD)	<p>This subarea is required to provide ground-floor commercial uses along a Primary Frontage, at a minimum depth of 25 feet or the entire depth of the building (whichever is less), for a minimum of 75% of the length of the Primary Frontage, excluding any area used for pedestrian and vehicular circulation.</p> <p>In these subareas, dwelling units are limited to upper floors above non-residential uses, or behind non-residential uses that are at least 25 feet in depth.</p>

SECTION 2: DEVELOPMENT STANDARDS

A. Height & Floor Area

1. Projects are subject to the height and floor area ratio limitations set forth in Table III below.

Table III—Height and Floor Area Ratio (FAR) Limitations			
Subarea	Height	FAR	Clarifications
A: Neighborhood Commercial	30 feet	1.5:1	
B: Commercial Only	45 feet	1.5:1	
C: Auto-Related Commercial	45 feet	1.5:1	
D: Commercial Center	45 feet	1.5:1	
E: Mixed-Use Corridor	Up to 45 feet	Up to 3:1	<p>Mixed-Use: The maximum height for Projects with a residential component is 45 feet with a maximum FAR of 3:1.</p> <p>Commercial Only: The Maximum height is 35 feet with a maximum FAR of 1.5:1.</p>
F: Transit-Oriented Development (TOD)	Up to 60 feet	Up to 3:1	<p>Mixed-Use: The maximum height for Projects with a residential component is 60 feet with a maximum FAR of 3:1.</p> <p>Commercial Only: The maximum height is 35 feet with a maximum FAR of 1.5:1.</p>

B. Building Orientation & Site Planning

1. The following Table IV applies to all subareas located within the Commercial District.

Table IV—Location of Buildings			
Subarea	Minimum Front Yard Setback	Maximum Front Yard Setback	Clarifications
A: Neighborhood Commercial	18 inches	5 feet	<p>A portion of the building frontage facing a public street may be recessed greater than the maximum front yard setback to provide for courtyards, entry plazas, forecourts or similar pedestrian amenities provided all of the following occurs:</p> <ul style="list-style-type: none"> • Courtyard recess is enclosed by buildings on three sides, with storefront entrances and windows fronting onto the courtyard. • Courtyard recess extends no longer than 25 feet from the front property line. • Courtyard recess extends no longer than 60 feet along the front property line.
B: Commercial Only			
C: Auto-Related Commercial			

D: Commercial Center	18 inches	15 feet	Buildings shall be set back precisely 18 inches from the property line; however, buildings may be set back up to 15 feet from the front property line when improved with pedestrian amenity space, such as plazas and outdoor dining areas, to the satisfaction of the Department of City Planning.
E: Mixed-Use Corridor			<p>Buildings shall be set back precisely 18 inches from the property line; however, buildings may be set back up to 15 feet from the front property line when improved with pedestrian amenity space, such as plazas and outdoor dining areas, to the satisfaction of the Department of City Planning.</p> <p>For Projects located on corners (at street intersections) buildings shall be located within five feet of the corner property line.</p>
F: Transit-Oriented Development (TOD)			<p>San Fernando Road shall be considered the Primary Lot Line for any project that abuts both San Fernando Road and Truman Street.</p> <p>Projects with a Primary Lot Line on San Fernando Road, north of Bleeker Street, shall be set back precisely 18 inches from the property line; however, buildings may be set back up to 15 feet from the front property line when improved with pedestrian amenity space, such as plazas and outdoor dining areas, to the satisfaction of the Department of City Planning.</p> <p>For Projects located on corners (at street intersections) buildings shall be located within five feet of the corner property line.</p>

C. Building Elevations & façade

1. For every 25 horizontal feet of building facade facing a street, a building shall incorporate at least one item from three of the four following categories:
 - a. Category 1: Columns, pilasters, posts, or trellises.
 - b. Category 2: Wall recesses, projections, or offsets.
 - c. Category 3: Arcades, awnings, or canopies.
 - d. Category 4: Windows or storefront bays.
2. The Primary Frontage of any building that has non-residential uses on the ground floor shall consist of at least 50 percent transparent doors and windows.
3. Buildings entrances and/or windows shall include at least one item from three of the four following categories:
 - a. Category 1: Projections or recessed entrances and windows with a minimum four-inch recess.
 - b. Category 2: Decorative pedestrian lighting.
 - c. Category 3: Courtyards, entryways, landings, porches, or stoops.
 - d. Category 4: Planter boxes, windowsills, shutters, canopies, or awnings.
4. A decorative screen wall, a trellis with climbing vines or plant materials, a landscaped planting bed, or other continuous architectural element shall be installed on all blank walls facing a street or parking lot.
5. External security grills and bars are prohibited.

D. Entrances & Pedestrian Circulation

1. A primary building entrance facing the street for each ground floor commercial use fronting a public street shall be provided. Storefront entrances shall be articulated and provide shelter for persons entering and exiting the building by providing recessed pedestrian entrances that are not flush with the edge of the building.
2. Residential projects shall be designed to ensure that all street-fronting dwelling units have a primary entrance facing the street. Space for entry, front landing, and transitional landscaping shall be provided between the public sidewalk and private entryway to residential projects. For residential projects without ground floor entrances for individual units, a prominent ground or first floor entry shall be created, such as a lobby or atrium, along the primary frontage.

3. Pedestrian entrances shall be located at grade level or within three feet of the adjacent sidewalk grade. Below grade or sunken entrances are prohibited.
4. Pedestrian pathways leading directly from the public sidewalk to the primary building entrance or entrances, pedestrian amenity spaces, and parking areas shall be provided. A change in grade, materials, textures, colors, or landscaping to improve pedestrian visibility and safety shall be used.
5. For new buildings where a sidewalk does not currently exist, a new sidewalk shall be installed along the length of the public street fronting the property.
6. Ancillary lighting shall be provided along pedestrian and vehicular access ways. All outdoor lighting and direct lighting shall be shielded onto the pathway.

E. Parking & Vehicular Circulation

1. Standards

- a. No additional parking is required for a change of use, within an existing building to a use permitted by this CPIO District, provided that the existing on-site parking is maintained.
- b. A minimum of one on-site parking space for each 500 square feet of combined floor area of commercial uses contained within all buildings on a lot is required.
- c. For Projects located within Subarea E (Mixed-Use Corridor) and Subarea F (Transit-Oriented Development), a maximum of 50 percent of the required parking spaces may be provided off-site, but within 1,500 feet of the lot for which they are provided. The applicant shall record a covenant and agreement securing the off-site parking.

2. Design

- a. For new developments, new surface parking shall be located at the rear or side of buildings and/or provide a semi-subterranean or subterranean garage. Vehicle parking areas are prohibited between the Primary Frontage and the Primary Lot Line.
- b. For new developments, Projects shall be designed so that side streets or alleys are the primary point of vehicular access to off-street parking, loading areas, and trash enclosures, unless determined infeasible by the Department of Transportation.
- c. Architectural treatments shall be incorporated into all portions of parking structure facades. These treatments shall include features such as arches or other architectural openings, and use varied building materials, decorative screening, climbing vines, or green walls.
- d. For new on-site surface parking which abuts a sidewalk and/or street, a maximum 42-inch in height hedge or landscaped wall or fence shall be installed

within five feet of the entire length of the street-fronting property line, with the exception of driveways and walkways.

F. Open Space

1. For new developments in Subarea D (Commercial Center), a minimum of 10 percent of the gross lot area shall be provided as usable open space that is visible and accessible from the sidewalk. A minimum of 50 percent of the required open space shall be unencumbered with any structure, except for artwork, play equipment for children, fencing, furniture, or similar features.
2. Projects located in Subarea F (Transit-Oriented Development), on San Fernando Road between Bleeker and Astoria Street, are required to incorporate usable open space according to the following:
 - a. For every 100 square feet of non-residential floor area, one square foot of open space shall be provided. The minimum open space area is 300 square feet, with a maximum of 5,000 square feet of open space required for the project site.
 - b. Open space shall be visible and accessible from the Primary Frontage sidewalk and include pedestrian amenities, such as benches, landscaping, water features, and tables.

G. Yards, Parkways, & Fences

1. Landscape
 - a. Public right-of-way parkways shall be improved with landscaping that separates the curb from the sidewalk with native and/or drought tolerant species, low-growing vegetation, or permeable materials, and shade street trees. Trees shall be planted along parkways to the satisfaction of the Urban Forestry Division, Bureau of Street Services.
 - b. A minimum five foot in depth landscaped setback buffer shall be provided adjacent to abutting residential zones or uses. Trees shall be planted within the setback at a ratio of at least one tree for every 25 feet of linear lot length. The minimum size of trees when planting shall be a 24-inch box size, and at least six feet in height.
 - c. Native and/or drought tolerant plant species shall be used and installed with an automatic irrigation system or comparable watering system on all landscaped areas.
2. Fences & Freestanding Walls
 - a. Fences and free-standing walls within five feet of the front and side yard setback areas facing a street shall not exceed 42 inches in height.

- b. When fences or free-standing walls are adjacent to a street, a minimum 18-inch landscaped setback buffer between the fence/wall and street for a minimum of 60 percent of the street frontage shall be provided. Plant species shall reasonably conceal the fence/wall, such as vines or other similar species. Plants and shrubbery within five feet of the setback area adjacent to a street shall not exceed 42 inches in height.
- c. Barbed wire, razor wire, chain link, and other similar fence types are prohibited. Wrought iron fences shall be dark-colored, such as black, brown, or dark green.

H. Signs

- 1. The following Table V regulations apply to all subareas, unless otherwise noted.

Table V—Prohibited Signs		
Type	Regulation	Exemptions/ Clarifications
Digital, flashing, animated, blinking, or scrolling sign or any sign that appear to have any movement	Prohibited	
Illuminated architectural canopy sign	Prohibited	
Inflatable Devices	Prohibited	
Pole Sign	Restricted/ Prohibited	This sign type is allowed only in Subarea D Commercial Center. (See Pole Sign section for details.)
Roof Sign	Prohibited	

- 2. Wall & Awning Signs

- a. Each premise or business is allowed a wall and an awning sign. An additional wall and awning sign are permitted if the premise abuts another street, alley, or public parking area. The additional signs shall face that portion of the building façade facing the abutting street, alley, or public parking area.
- b. Maximum wall sign area is limited to 1.5 square feet per linear feet of the building frontage. An individual wall sign shall not exceed 150 square feet.
- c. The text of the awning sign shall be located on the valance portion of the awning. Backlit, internally illuminated awnings are prohibited. The use of replaceable valances should be considered on awnings.

- d. Glossy, vinyl, plastic, metal and horizontal ribbed awnings are prohibited.
- e. A maximum of three colors for each awning, exclusive of signage, is allowed.

3. Projecting Signs

- a. Each business may have a projecting sign on the ground floor level. Where multiple businesses exist, there shall be no more than one projecting sign per every 25 linear feet of street frontage.
- b. The size of a projecting sign shall be limited to 15 square feet with a minimum eight feet clearance between the sign and the sidewalk. The projection shall be no less than six inches and no more than 36 inches from the building facade. Signs shall be positioned at a 90-degree angle from the face of the building so that the maximum height of the top of the sign does not exceed 14 feet above the sidewalk or the first floor ceiling line, whichever is less. Internal illumination is prohibited.

4. Monument Signs

- a. One monument sign per lot is permitted. Projects located within Subarea D (Commercial Center) are allowed a total of two monument signs.
- b. The height of the top of the monument sign shall not exceed a maximum of six feet above the sidewalk grade. Monument signs shall be located within a landscaped area that is equal to or greater than the dimensions of one face of the sign.
- c. Monument signs facing alleys or residentially-zoned lots shall not be internally illuminated.

5. Pole Signs

- a. One pole sign in lieu of the two monument signs is allowed within Subarea D (Commercial Center). The height of the top of the pole sign shall not exceed a maximum 30 feet above the sidewalk grade. The pole sign shall be located within a landscaped area that is equal to or greater than the dimensions of one face of the sign.
- b. All poles used in a pole sign shall be fully enclosed by a pole cover.

I. **Equipment & Utilities**

1. Equipment

- a. Rooftop equipment, such as air conditioning units, antennas and communication equipment, mechanical equipment, and vents, shall be screened from street view. Equipment shall be located a minimum of five linear feet from a roof edge.

- b. All exterior mechanical equipment, utilities, storage areas, and trash bins shall be enclosed or screened with materials that are similar to those used in the primary structure.

2. Utilities

- a. Utilities, such as gas, electric, and water meters, shall be placed in side yard setbacks or in landscaped areas that are out of the line-of-sight from crosswalks or sidewalks.
- b. Utilities, such as power lines, transformers, and wireless facilities, located on rooftops shall be concealed by a parapet.

J. Equestrian Trails & Amenities

1. Development projects that require a dedication and/or improvements and projects which abut or connect with an identified trail are encouraged to dedicate and/or improve the trail network according to the Sylmar Community Plan General Plan Land Use Map.
2. Trails and amenities shall be designed to be consistent with the policies and the Design Guidelines for Trails set forth in Chapter 4 of the Sylmar Community Plan and Appendix A herein.
3. Safety measures, such as signage, crosswalks, and rider-height signal actuator buttons, shall be incorporated as deemed necessary by the Department of Transportation.

OVERVIEW

To ensure that development within the Sylmar CPIO District does not negatively impact the surrounding community or environment, Projects within the Industrial Subarea (see Figure III), shall comply with the applicable Supplemental Development Regulations in this Chapter III.

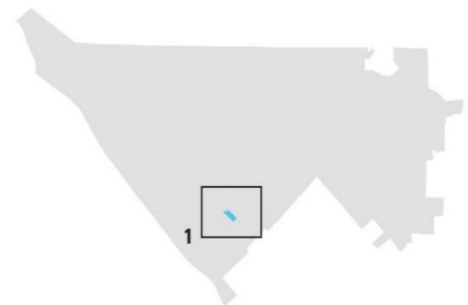

Figure III
Industrial Subarea
Sylmar Community Plan Area

SECTION 1: DEVELOPMENT STANDARDS

A. Height

1. The maximum height for a Project is 30 feet.

B. Building Orientation & Site Planning

1. The Primary Frontage for new buildings shall be built within five feet of San Fernando Road, which shall be considered the Primary Lot Line.

C. Building Facade

1. A primary building entrance shall be provided on San Fernando Road.
2. A decorative screen wall, a trellis with climbing vines, or screening vegetation, a landscaped planting bed, or other continuous architectural element, shall be installed on all blank walls facing San Fernando Road.
3. External security grills and bars are prohibited fronting San Fernando Road.

D. Parking & Vehicular Circulation

1. Design
 - a. For new developments, new surface parking shall be located at the rear or side of buildings and/or the applicant shall provide a semi-subterranean or subterranean garage. Vehicle parking areas are prohibited between the Primary Frontage and the Primary Lot Line.
 - b. Architectural treatments shall be incorporated into all portions of parking structure facades. These treatments shall include features, such as arches or other architectural openings, and varied building materials, decorative screening, climbing vines, or green walls.
 - c. For new on-site surface parking that abuts a sidewalk and/or street, a maximum 42-inch in height hedge, berm, or landscaped wall or fence shall be provided within five feet of the entire length of the street-fronting property line, with the exception of driveways and walkways.

E. Yards, Parkways, & Fences

1. Landscape
 - a. Public right-of-way parkways (those that separate the curb from the sidewalk) shall be improved with native and/or drought tolerant plant species, low-growing vegetation, or permeable materials, and shade street trees. Trees shall be planted along parkways to the satisfaction of the Urban Forestry Division, Bureau of Street Services.

- b. A minimum five foot in depth landscaped setback buffer shall be provided adjacent to abutting residential zones or uses. Trees shall be planted, where feasible, within the setback at a ratio of at least one tree every 25 feet of linear lot length. The minimum size of trees at time of planting shall be 24-inch box size, and at least six feet in height.
- c. Native and/or drought tolerant plant species shall be used and installed with an automatic irrigation system or comparable watering system on all landscaped areas.

2. Fences & Freestanding Walls

- a. A minimum of six feet in height decorative masonry block wall shall be provided adjacent to residential uses.
- b. Fences and free-standing walls within five feet of the front and side yard setback areas facing a street shall not exceed 42 inches in height.
- c. When fences or free-standing walls are adjacent to a street, a minimum 18-inch landscaped setback buffer shall be provided between the fence/wall and street for a minimum of 60 percent of the street frontage. Plant species shall help conceal the fence/wall, including vines or other similar species. Plants and shrubbery within five feet of the setback area adjacent to a street shall not exceed 42 inches in height.
- d. Barbed wire, razor wire, chain link, and other similar fence types are prohibited. Wrought iron fences shall be dark-colored, such as black, brown, or dark green.

F. Signs

- 1. The following signs are prohibited as set forth in Table VII below.

Table VII—Prohibited Signs		
Type	Regulation	Exemptions/ Clarifications
Digital, flashing, animated, blinking, or scrolling sign or any sign that appear to have any movement	Prohibited	
Illuminated architectural canopy sign	Prohibited	
Inflatable Devices	Prohibited	
Roof Sign	Prohibited	

2. Wall & Awning Signs

- a. Each premise or business is allowed a wall and an awning sign per street frontage. Additional wall and awning signs are permitted if the premise abuts a

secondary street, alley, or public parking area. The additional signs shall face that portion of the building facade facing the abutting secondary street, alley, or public parking area.

- b. Maximum wall sign area is limited to 1.5 square feet per linear feet of the building frontage. An individual wall sign shall not exceed 150 square feet.
- c. The text of the awning sign shall be located on the valance portion of the awning. Backlit, internally illuminated awnings are prohibited. The use of replaceable valances should be considered on awnings.
- d. Glossy, vinyl, plastic, metal and horizontal ribbed awnings are prohibited.
- e. A maximum of three colors for each awning, exclusive of signage, is allowed.

3. Projecting Signs

- a. Each business may have a projecting sign on the ground floor level. Where multiple businesses exist, there shall be no more than one pedestrian sign per every 25 linear feet of street frontage.
- b. The size of a projecting sign is limited to 15 square feet with a minimum eight feet clearance between the sign and the sidewalk. The projection shall be no less than six inches and no more than 36 inches from the building facade. Signs shall be positioned at a 90-degree angle from the face of the building so that the maximum height of the top of the sign is no more than 14 feet above the sidewalk or the first floor ceiling line, whichever is less. Internal illumination is prohibited.

4. Monument Signs

- a. One monument sign is permitted per lot.
- b. The height of the top of the monument sign is limited to a maximum of six feet above the sidewalk grade. Monument signs shall be located within a landscaped area that is equal to or greater than the dimensions of one face of the sign.
- c. Monument signs facing alleys or residentially-zoned lots shall not be internally illuminated.

5. Pole Signs

- a. One pole sign in lieu of the monument sign is allowed. The height of the top of the pole sign is limited to a maximum 30 feet above the sidewalk grade. The pole sign shall be located within a landscaped area that is equal to or greater than the dimensions of one face of the sign.
- b. A pole used in a pole sign shall be fully enclosed in a pole cover.

G. Equipment & Utilities

1. Equipment

- a. Rooftop equipment, such as air conditioning units, antennas and communication equipment, mechanical equipment, and vents, shall be screened from street view. Equipment shall be located a minimum of five linear feet from a roof edge.
- b. All exterior mechanical equipment, utilities, storage areas, and trash bins shall be enclosed and/or screened with materials that are similar to those used in the primary structure.

2. Utilities

- a. Utilities, such as gas, electric, and water meters, shall be placed in side yard setbacks, or in landscaped areas that are out of the line-of-sight from crosswalks or sidewalks.
- b. When located on rooftops, utilities, such as power lines, transformers, and wireless facilities, shall be screened by a parapet.

OVERVIEW

To ensure that development within the Sylmar CPIO District does not negatively impact the surrounding community or environment, Projects that are within the Multiple Family Residential Subarea (see Figure IV), shall comply with the applicable Supplemental Development Regulations in this Chapter IV.

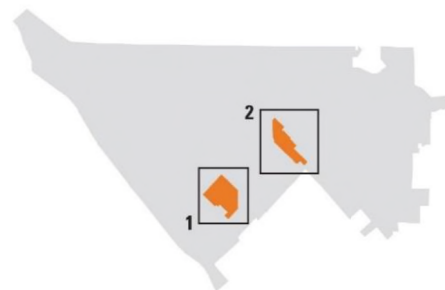
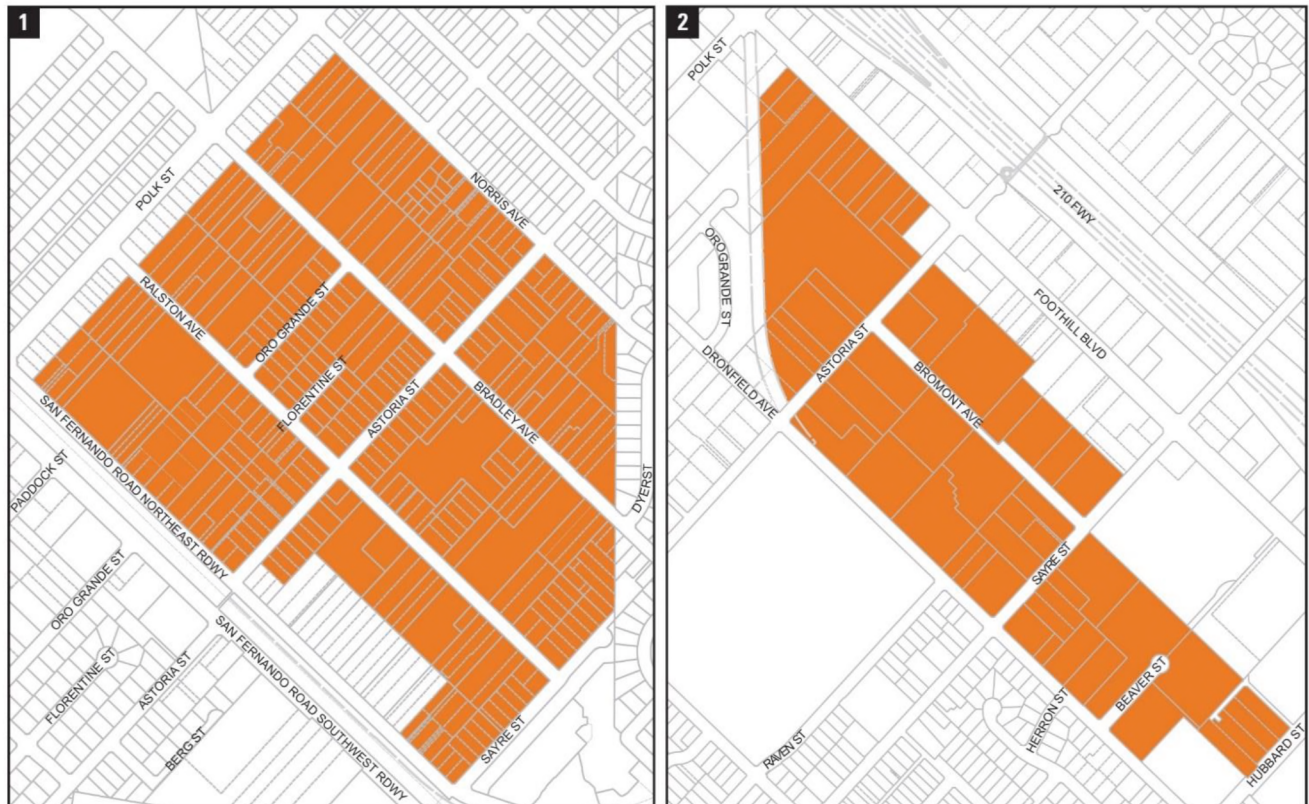

Figure IV
Multiple Family Residential Subarea
 Sylmar Community Plan Area

SECTION 1: DEVELOPMENT STANDARDS

A. Height & Floor Area

1. In addition to the height and floor area regulations of the underlying zone and height district, where buildings exceed 30 feet in height and where the rear or side yard property is contiguous with a single-family residential zone, the building shall be set back, or stepped back, one foot for every foot in height as measured 15 feet above grade at the shared property line.

B. Building Orientation & Site Planning

1. Buildings shall be oriented towards the Primary Lot Line.
2. Where there is an existing prevailing front yard setback, buildings shall adhere to that setback in order to provide continuity along the street edge. If there is no prevailing setback, the setback shall be within five feet of the average setback of adjacent properties.

C. Building Elevations & Facades

1. Windows are required on all building facades that front a public street. All windows along the building facade fronting a street shall incorporate at least one standard from one of the following four categories:
 - a. Category 1: Mullions and/or transoms
 - b. Category 2: Trim or molding at least four inches in width
 - c. Category 3: Canopies, shutters, or awnings proportional to window size
 - d. Category 4: Recessed inset from the front facade by at least four inches
2. For every 25 horizontal feet of building facade facing a street, a building shall incorporate a minimum of three design features from the following five categories:
 - a. Category 1: Roof forms, such as gables or dormers
 - b. Category 2: Bays, projecting porches, or balconies
 - c. Category 3: Columns, pilasters, posts, or trellises
 - d. Category 4: Wall recesses or offsets
 - e. Category 5: Eaves or cornices
3. External security grills and bars are prohibited.

D. Entrances & Pedestrian Circulation

1. All street-fronting ground floor residential units shall provide a primary entrance facing the street. Garage entries may not be counted as a primary entrance.
2. For projects without ground floor entrances for individual units, a prominent ground or first floor entry, such as a lobby or atrium, shall be created along the Primary Frontage.
3. Pedestrian entrances shall be located at grade level or within three vertical feet of the adjacent sidewalk grade. Below grade or sunken entrances are prohibited.
4. Design elements or features, such as landscaping, paving, stoops, porches, arcades and/or canopies, shall be incorporated at the primary entrance to each residence. Similar treatments shall be applied for any prominent ground or first floor entry.
5. Pedestrian pathways shall lead directly from the sidewalk to the front porch/entry of each dwelling unit and any common entrance. In addition, pedestrian pathways shall be provided between dwelling units and parking areas, recreational areas, common outdoor space and any pedestrian amenity. A change in grade shall use materials, textures, colors, or landscaping to improve pedestrian visibility and safety.
6. For new residential projects where a sidewalk does not currently exist, a new sidewalk shall be established along the length of the public street fronting the property.
7. Ancillary lighting shall be provided along pedestrian and vehicular access ways. All outdoor lighting and direct lighting shall be shielded onto the pathway.

E. Parking & Vehicular Circulation

1. Design
 - a. For new developments, new surface parking shall be located at the rear or side of buildings and/or a semi-subterranean or subterranean garage shall be provided. Vehicle parking areas are prohibited between the Primary Frontage and the Primary Lot Line.
 - b. For new developments, projects shall be designed so that side streets or alleys are the primary point of vehicular access to off-street parking, loading areas, and trash enclosures, unless determined infeasible by the Department of Transportation.
 - c. Architectural treatments shall be incorporated into all portions of parking structure facades. These treatments shall include features such as arches or other architectural openings, and varied building materials, decorative screening, climbing vines, or green walls.
 - d. For new on-site surface parking that abuts a sidewalk and/or street, a maximum

42-inch shall be provided in height hedge, berm, or landscaped wall or fence within five feet of the entire length of the street-fronting property line, with the exception of driveways and walkways.

F. Open Space

When designing subdivisions per Los Angeles Municipal Code section 12.22 C. 27, a minimum of 250 square feet of usable private open space shall be provided at grade level per dwelling unit. The required private open space for individual units fronting an existing public street may be located in the front yard. Parking areas, including access aisles and driveways, do not qualify as usable open space.

G. Yards, Parkways, & Fences

1. Landscape

- a. When Projects require street dedication and/or improvements, the public right-of-way parkways separating the curb from the sidewalk shall be planted with native and/or drought tolerant species, low-growing vegetation, or permeable materials, and shade street trees. Trees shall be planted along parkways, to the satisfaction of the Urban Forestry Division, Bureau of Street Services.
- b. The paving of front and side yard setback areas facing a street not used for driveways and walkways is prohibited. Permeable paving materials, such as permeable pavers and grid systems filled with gravel or grass, shall be used where allowed by Code.
- c. A minimum five feet in depth landscaped setback buffer shall be provided on all side and rear yard setbacks. Trees shall be planted within the setback at a ratio of at least one tree every 25 feet of linear lot length. The minimum size of trees at time of planting shall be 24-inch box size, and at least six feet in height.
- d. Native and/or drought tolerant plant species shall be used and installed with an automatic irrigation system on all landscaped areas.

2. Fences & Freestanding Walls

- a. Fences and free-standing walls within five feet of the front and side yard setback areas facing a street shall be limited to 42 inches in height.
- b. When fences or free-standing walls are adjacent to a street, a minimum 18-inch landscaped setback buffer shall be provided between the fence/wall and street for a minimum of 60 percent of the street frontage. Plant species shall reasonably conceal the fence/wall, including vines or other similar species. Plants and shrubbery within five feet of the setback area adjacent to a street shall not exceed 42 inches in height.
- c. Barbed wire, razor wire, chain link, and other similar fence types are prohibited. Wrought iron fences shall be dark-colored, such as black, brown, or dark green.

H. Equipment & Utilities

1. Equipment

- a. Rooftop equipment, such as air conditioning units, antennas and communication equipment, mechanical equipment, and vents, shall be screened from street view.
- b. All exterior mechanical equipment, utilities, storage areas, and trash bins, shall be enclosed and/or screened with materials that are architecturally integrated into the building, landscaping, or designed to appear inconspicuous.

2. Utilities

- a. Utilities, such as gas, electric, and water meters, shall be placed in side yard setbacks or in landscaped areas that are out of the line-of-sight from crosswalks or sidewalks.
- b. When located on rooftops, utilities, such as power lines, transformers, and wireless facilities shall be screened by a parapet.

I. Equestrian Trails & Amenities

1. Development projects that require a dedication and/or improvements and projects which abut or connect with an identified trail are encouraged to dedicate and/or improve the trail network according to the Sylmar Community Plan General Plan Land Use Map.
2. Trails and amenities shall be designed to be consistent with the policies and the Design Guidelines for Trails set forth in Chapter 4 of the Sylmar Community Plan and Appendix A herein.
3. Appropriate safety measures, such as signage, crosswalks, and rider-height signal actuator buttons, shall be incorporated as deemed necessary by Department of Transportation.

Design Guidelines for Residential Areas



The Sylmar Residential design guidelines in this Appendix and the Residential Citywide Design Guidelines establish the minimum level of design that shall be observed in all projects within the Sylmar Community Plan area. The intent of the design guidelines is to promote a stable and pleasant environment for the residents and users of the community. The design guidelines are intended to ensure that new structures, alterations and renovations to existing structures make a positive aesthetic contribution to the built environment, provide adequate public amenities and increase neighborhood identity. The overall goal and purpose of the design guidelines are to improve the community's identity and livability and to create unique, inviting and safe public spaces.

Early consultation with Planning staff, including consideration of long-term maintenance, is one of the essential way of assuring implementation of Citywide and these Sylmar Residential Design Guidelines

Character and Design

- G1. Ranch-style architectural details such as the use of low-pitched and hipped roofs, deep-set eaves, large picture windows, recessed entryways, varying front setback planes, wooden or brick exterior wall siding, and/or L-shaped design should be incorporated to encourage and enhance the traditional post-World War II character found in many of Sylmar's single-family residential neighborhoods.
- G2. The suburban character of the neighborhood should be maintained by configuring buildings to front public streets, not driveways. Corner buildings should be designed to be prominent by building to both the front and side property lines facing a street. In detached condominiums or small lot subdivisions, the unit closest to the primary street should be oriented towards the street.

Design Guidelines for Residential Areas (continued)



See G3-G8



See G9

- G3. New development should be changed so that it continues to engage the street, sidewalk, and public realm by providing individual entrances, large windows, porches, or other entry features to face a street.
- G4. Compatible heights of buildings should be maintained with adjacent and nearby buildings to help preserve the existing low-lying character of Sylmar's single-family residential neighborhoods. Second floor or higher stepbacks should be consistent with prevailing or adjacent buildings.
- G5. Development entryways should be situated within three feet above the grade of the sidewalk to avoid buildings and entryways that tower above or are sunken below the street.
- G6. Existing neighborhood setbacks should be matched and on streets with varying setbacks, align dwellings between the existing maximum and minimum setback.
- G7. Building volumes and façade articulation should be modulated to help convey a sense of individual units and enhance the pedestrian experience. To break massing, multiple planes, stepbacks and architectural treatments such as recessed windows, columns, moldings, and projections should be used. The heights and rooflines should be varied, and offsets in wall planes on all elevations should be used to reduce the visual scale and provide visual interest to a building and individual units.
- G8. The repetitive use of a single building configuration or façade design should be avoided. Provide rhythm to building elevations which adds unity and interest without monotony. Architectural features, such as balconies, porches, decks, awnings, arcades, trellises, color, materials, and diverse roof forms should be used. Landscape features, such as trees, shrubs, and vines should be used to create articulation and a diverse building façade.
- G9. A collection of buildings should be arranged to frame outdoor places, such as a landscaped focal point or courtyard.

Design Guidelines for Residential Areas (continued)



See G10-G11



See G14

Circulation and Parking

- G10. Prevailing garage location and driveway patterns should be considered and incorporated into the design scheme. Innovative design schemes are encouraged that minimize the visual impact of garages facing the street.
- G11. The appearance of parking areas should be minimized by locating parking areas to the rear of buildings and/or providing parking underground, landscaping visible parking areas. Parking areas should not be sited on corners adjacent to intersections.
- G12. Decorative walls and/or landscaping should be used to buffer residential uses from parking areas and structures. Parking structure exteriors should be designed to match the style, materials and color of the main building to integrate parking with the design of buildings.
- G13. The number of curb cuts and width of driveways should be the minimum required by the Department of Transportation (DOT).
- G14. Pedestrian pathways should be separated from auto circulation routes by providing landscaped sidewalks and walkways from sidewalk for homes not adjacent to the street. A change in grade, materials, textures or colors should be used to improve pedestrian visibility and safety. The amount of elevation changes should be minimized through careful grading so as to facilitate disabled access.

Design Guidelines for Residential Areas (continued)



See G15-G17



See G15

Landscaping, Fences, and Walls

- G15. Open and inviting yard setbacks and parkways should be provided that are landscaped with a variety of native and/or drought tolerant plant materials, which contribute to the suburban character of this residential community.
- G16. Gated or walled communities should not isolate the project from the neighborhood and surrounding community.
- G17. Low-lying, open fence design should be used. Walls and fences within the street-side setback areas should be limited to 42 inches in height in order to provide front entries that are visible from the street. The setback areas should be attractively landscaped with native and/or drought tolerant plants to screen and enhance their appearance.
- G18. Barbed wire and razor wire fencing should not be used. Alternatives to chain link fencing should be considered.

Design Guidelines for Residential Areas (continued)

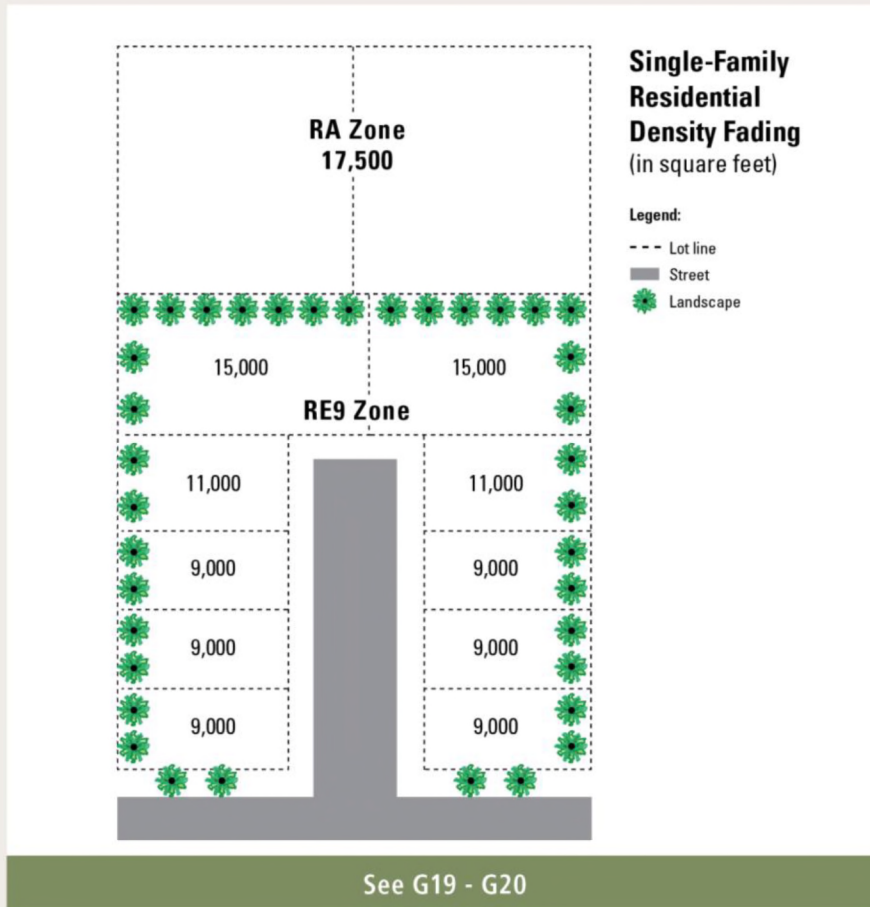

Neighborhood Transitions

- G19. Lots should be increased in size so as to more closely conform to the size of existing contiguous lots or nearby parcels.
- G20. New development should be transitioned with regard to lot size (density fading) and width so that new parcels are compatible with existing adjacent lots and surrounding neighbors.
- G21. Buildings setbacks for the zoning district should be considered a minimum. Larger setbacks should be provided for multiple-family projects adjacent to single-family and equinekeeping lots.

Design Guidelines for Residential Areas (continued)

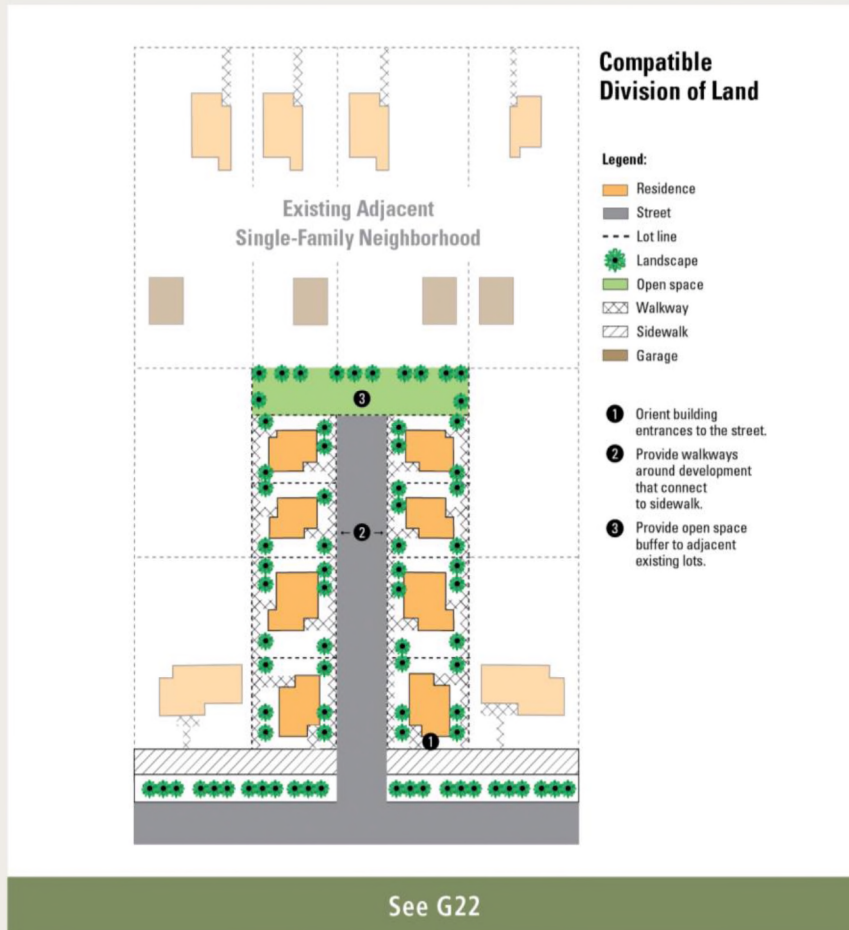

G22. Open space should be provided and located next to lower intensity uses in order to increase building separations and intensify landscaping between the development and adjacent uses to help mitigate impacts, particularly visual intrusion on private outdoor space of adjacent backyards.

G23. Building heights and mass should be positioned according to the intensity of the adjacent use. Shorter buildings with small footprints should be sited near lower intensity uses while taller, more massive buildings should be located near higher intensity uses and toward the center of the site. Shorter walls should be sited near small structures.

Design Guidelines for Residential Areas (continued)

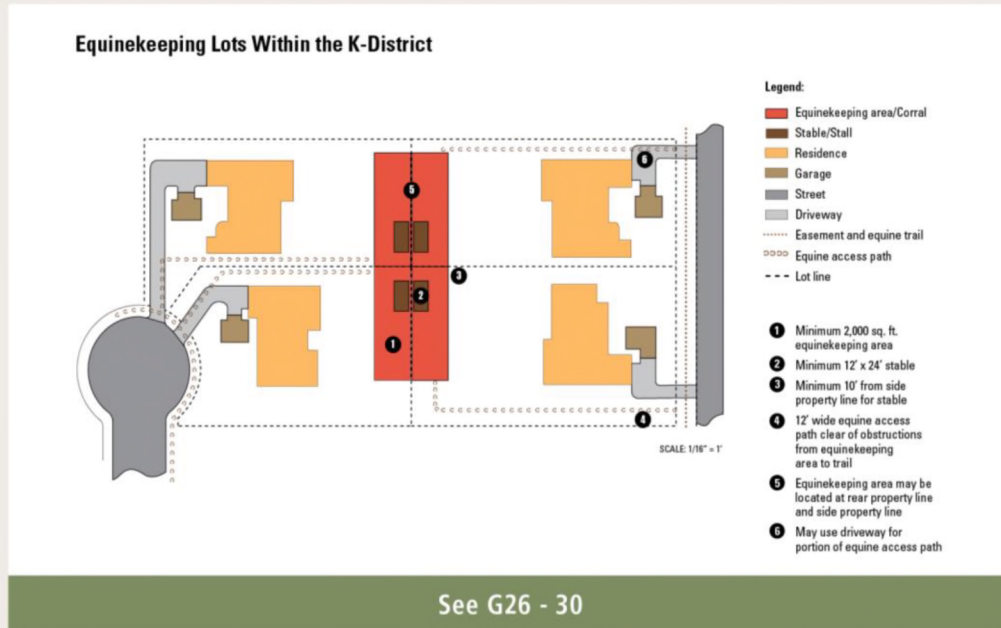

Equestrian-Oriented Neighborhoods

- G26. A 2,000 contiguous square-foot level pad area should be maintained with a minimum width of 24 feet, including a 12'x24' (288-square foot) equine stable area. The pad area should include a 12'x12' (144-square foot) area for storage of feed and equipment, should be graded to permit quick and adequate drainage, and should be permanently set aside for equine use. No permanent structure, including swimming pools and tennis courts, should be constructed or located within any portion of the pad area. Such structures may be permitted outside of the required equine stable and pad areas.
- G27. On small lot subdivision lots, communal equestrian facilities are encouraged in townhouse and detached condominium developments.
- G28. Equine pad and stable areas may be located at the rear property line. Reduced front yard setbacks may be considered to enlarge the backyard area for the purposes of optimizing the intended use of the level pad area and minimizing overall grading and to allow for a better layout for equines and is allowed as long as the reduction does not endanger the equinekeeping use.
- G29. On all lots, the equine pad area may be located within required side yard setbacks depending on the unique features of a site.
- G30. Where access is taken from the front facing street, a 12-foot wide equine access path should be provided. A driveway which is a minimum of 12-feet in width may function dually as an equine access path for the portion of the path that extends from the street to the end of the driveway. Permeable driveway materials are preferred.

Design Guidelines for Trails

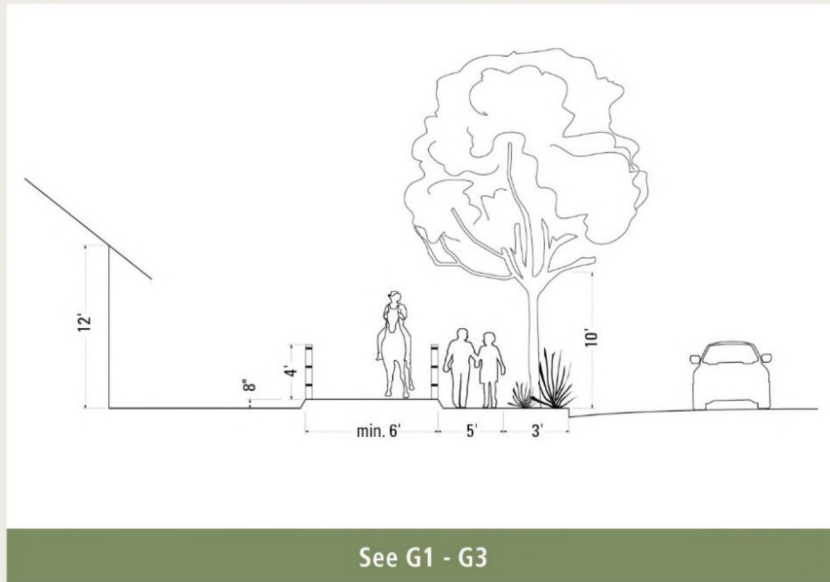

- G1 Trails adjacent to streets should be designed to be a minimum of 6 feet in width to accommodate a single track. Preferred trail width adjacent to streets is between 10 and 12 feet to accommodate a double track.
- G2 A vertical clearance of 10 feet should be maintained from the ground and any physical barrier such as bridges, underpasses, and should maintain vegetation free of protruding branches.
- G3 A maximum height of 4 feet is recommended for all fences and barriers along trails. A greater height may be permitted for trails adjacent to high speed roads where traffic may startle horses. Height should be tapered down as trail approaches intersections or end, to maximize horse/ rider view.
- G4 Low walls or fences with railings added for more height are acceptable. Bollards, barrier posts, or rail tie "stopovers" at forest/mountain trail head can help separate equestrian from other uses. Barrier posts should be an odd number to prevent confusion, and placed 5 feet apart to allow equestrians to pass through.

Design Guidelines for Trails (continued)

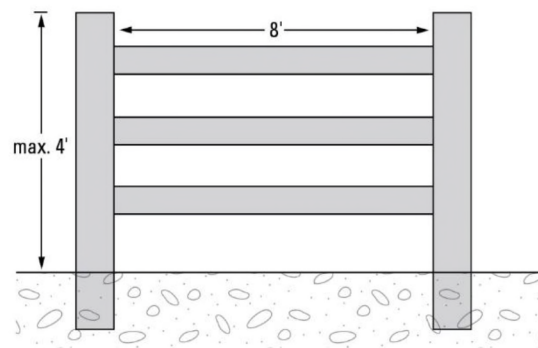

See G5

- G5 Preferred fence materials include any sturdy material that gives the appearance of wood-like finish.
- G6 Use of native plants for landscaping is encouraged. Low walls or fences can include vegetation facing the trail to improve appearance, especially along trails with pipe railing. Vegetation should be trimmed to less than 4 feet high for crime prevention purposes, and trimmed to avoid injury to equines. Plants toxic to equines, such as oleander, must be removed.
- G7 Trails adjacent to or within 6 feet of ditches or steep slopes that rise more than one foot in 3 feet and have drop off of over 2.5 feet should begin at least 8 feet before and extend 8 feet beyond the vertical hazard. A minimum 3 foot shoulder from the rail edge to the trail should be provided with an 8-inch maximum spacing between rails.

Design Guidelines for Trails (continued)

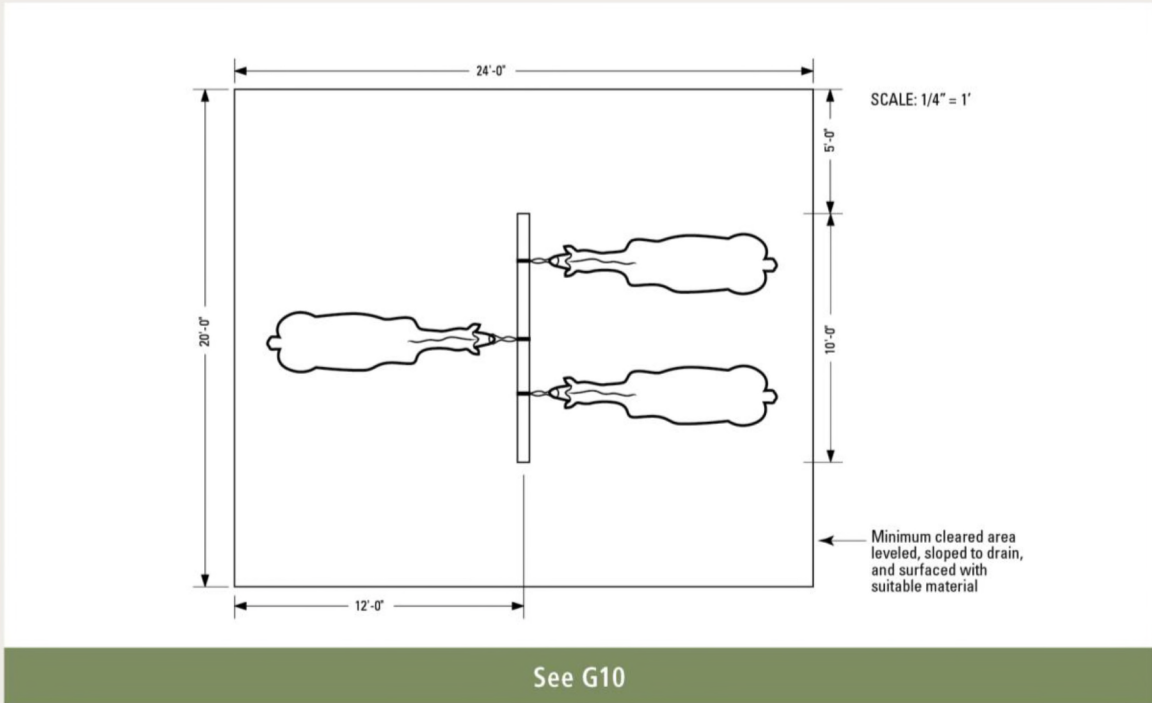

- G8 Trail treads should be a fine aggregate material such as decomposed granite or other non-slip, porous surface.
- G9 Trail easements/improvements that are adjacent to commercial and industrial sites should be located away from vehicular traffic, such as along the rear of the site, for safety.
- G10 Equine parking or hitching area separate from vehicle parking should be a minimum of 20 feet X 24 feet, leveled, sloped to drain, constructed of permeable surface, and maintained clear of vegetation and objects. Hitching areas should include a hitching rail located in the center of the hitching pad area and be clear of vehicular traffic. Minimum clearances should be observed.

Design Guidelines for Trails (continued)

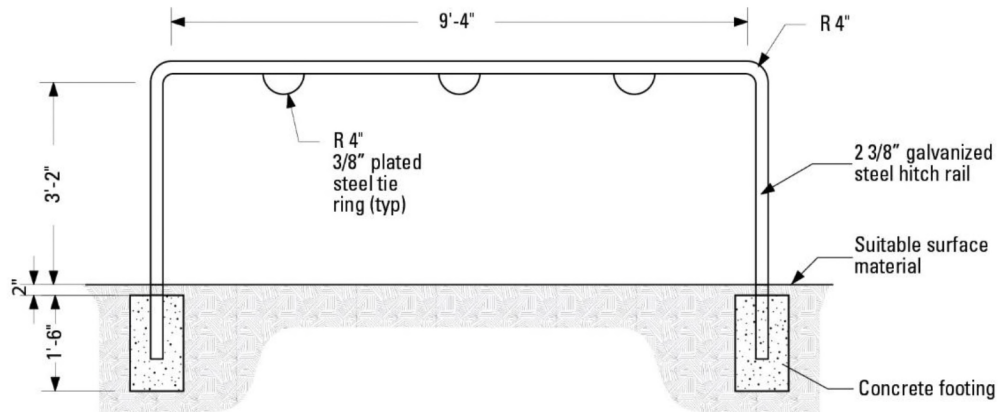

See G11-G12

- G11 The hitching rail(s) should accommodate small riding groups, be of durable material, finished with rounded edges and no overhanging ends, to avoid injuries, with welded loops or braces in the corners to confine lead ropes and prevent slippage. The hitching rails length should be a minimum of 4 feet with a height of 42 inches.
- G12 Solid metal hitching loops should be set into brick or concrete wall surrounding a vehicle parking lot to accommodate equestrian parking in existing or new lots. A soft surface is preferable, with a minimum 24-foot distance to the nearest vehicle parking space.
- G13 A second signal actuator push button, and equine crossing signal, 5 to 6 feet above the ground should be installed. The post should be set 6.5 feet from the road edge so that the animal’s head does not encroach into the roadway. The equestrian waiting area at the signalized crossing should be 25 feet X 15 feet.
- G14 The equestrian waiting area at a signalized crossing should include a landscaped median for horse refuge.

Design Guidelines (continued)

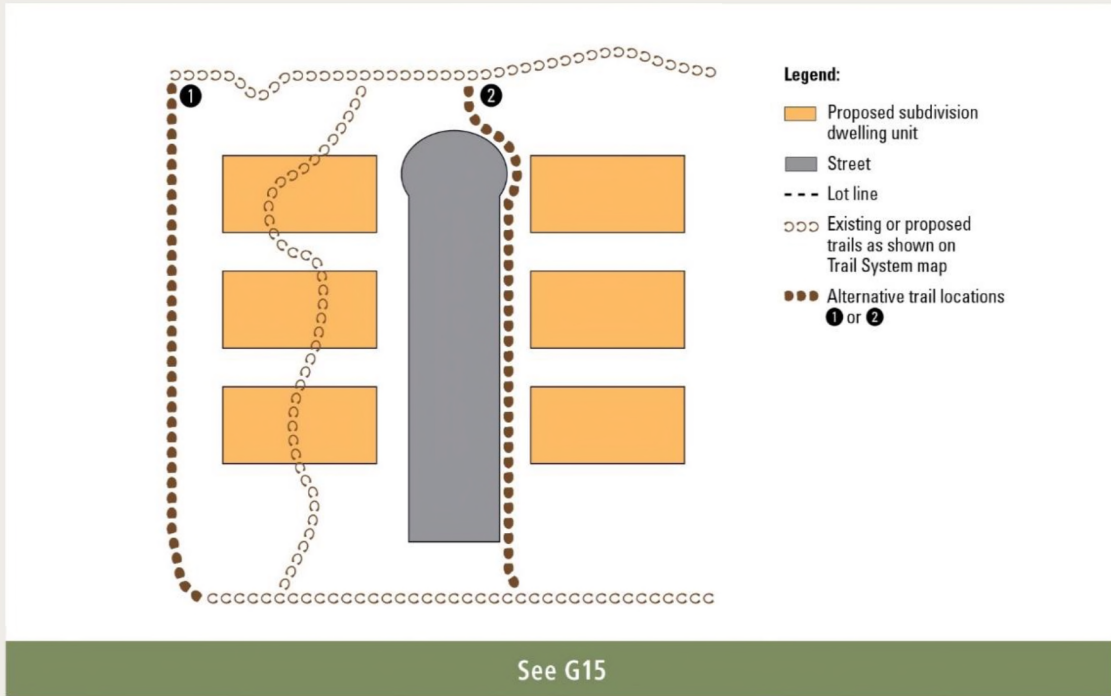

G15 The course of the trail should be altered to maximize land use as long as the altered course is safe and maintains connections and continuity to the Trail Network in Sylmar and other trails.

1. Include the following best air quality management practices in contract specifications and print on plans:
 - Use properly tuned and maintained equipment.
 - Enforce the idling limit of five minutes as set forth in the California Code of Regulations.
 - Use diesel-fueled construction equipment to be retrofitted with after treatment products (e.g. engine catalyts) to the extent they are readily available and feasible.
 - Use heavy duty diesel-fueled equipment that uses low NOx diesel fuel to the extent it is readily available and feasible.
 - Use construction equipment that uses low polluting fuels (i.e. compressed natural gas, liquid petroleum gas, and unleaded gasoline) to the extent available and feasible.
 - Maintain construction equipment in good operating condition to minimize air pollutants.
 - Utilize materials that do not require painting, as feasible.
 - Use pre-painted construction materials, as feasible.
 - Provide temporary traffic controls such as a flag person, during all phases of construction to maintain smooth traffic flow.
 - Provide dedicated turn lanes for movement of construction trucks and equipment on- and off-site, as feasible.
 - Re-route construction trucks away from congested streets or sensitive receptor areas, as feasible.
 - Appoint a construction relations officer to act as a community liaison concerning on-site construction activity including resolution of issues related to PM10 generation.
2. Require projects to implement applicable Greenhouse Gas reduction measures in the design of projects, including:
 - Install energy efficient lighting (e.g., light emitting diodes), heating and cooling systems, appliances, equipment, and control systems).
 - Install light colored “cool” roofs and cool pavements.
 - Create water-efficient landscapes.

- Install water-efficient fixtures and appliances.
3. Require all contractors to include the following best noise management practices in contract specifications and print on plans:
- Construction haul truck and materials delivery traffic shall avoid residential areas whenever feasible. If no alternatives are available, truck traffic shall be routed on streets with the fewest residences.
 - Locate construction staging areas away from sensitive uses.
 - When construction activities are located in close proximity to noise-sensitive land uses, noise barriers (e.g., temporary walls or piles of excavated material) shall be constructed between activities and noise sensitive uses.
 - Impact pile drivers shall be avoided where possible in noise-sensitive areas. Drilled piles or the use of a sonic vibratory pile driver are quieter alternatives that shall be utilized where geological conditions permit their use. Noise shrouds shall be used when necessary to reduce noise of pile drilling/driving.
 - Construction equipment shall be equipped with mufflers that comply with manufacturers' requirements.
 - Consider potential vibration impacts to older (historic) buildings.
4. For new buildings within **500 feet from the I-210 (Foothill Freeway)**, project applicants shall incorporate one of the following methods:
- Retain a qualified air quality consultant to prepare a health risk assessment (HRA) in accordance with the California Air Resource Board and the Office of Environmental Health and Hazard Assessment requirements to determine the exposure of project residents/occupants/users to stationary air quality pollutants prior to issuance of a demolition, grading, or building permit. The HRA shall be submitted to the Lead Agency for review and approval. The applicant or implementation agency shall implement the approved HRA recommendations, if any. If the HRA concludes that the air quality risks from nearby sources are at or below acceptable levels, then additional measures are not required.
 - Implement the following features that have been found to reduce air quality risk to sensitive receptors and shall be included in the project construction plans. These shall be submitted to the Planning Department for review and approval prior to the issuance of a demolition, grading, or building and ongoing.
 - Do not locate sensitive receptors near distribution center's entry and exit points.
 - Do not locate sensitive receptors in the same building as perchloroethylene dry cleaning facility.

- Maintain a 50' buffer from a typical gas dispensing facility (under 3.6 million gallons of gas per year).
- Install, operate, and maintain in good working order a central heating and ventilation (HV) system or other air take system in the building, or in each individual residential unit, that meets the efficiency standard of the MERV 13. The HV system shall include the following features: installation of a high efficiency filter and/or carbon filter-to-filter particulates and other chemical matter from entering the building. Either HEPA filters or ASHARE 85% supply filters shall be used.
- Retain a qualified HV consultant or HERS rater during the design phase of the project to locate the HV system based on exposure modeling from the mobile and/or stationary pollutant sources.
- Maintain a positive pressure within the building.
- Achieve a performance standard of at least 4 air exchanges per hour of recirculation.
- Achieve performance standard of .25 air exchanges per hour of an unfiltered infiltration if the building is not positively pressurized.
- Maintain, repair, and/or replace HV system or prepare an Operation and Maintenance Manual for the HV system and the filter. The manual shall include the operating instructions and maintenance and replacement schedule. This manual shall be included in the CC&R's for residential projects and distributed to the building maintenance staff. In addition, the applicant shall prepare a separate Homeowners Manual. The manual shall contain the operating instructions and maintenance and replacement schedule for the HV system and the filters. It shall also include a disclosure to the buyers of the air quality analysis findings.

5. For **residential development within 150 feet of the Union Pacific (UN) right-of-way**, prior to the submittal of a building permit application project applicants shall obtain a qualified vibration consultant to complete a site-specific vibration assessment subject to approval by the Department of Building and Safety. The vibration assessment shall measure the vibration levels at the project site's property line within 150 feet of the UP right-of-way. If vibration levels exceed the FTA 80 VdB criteria for "infrequent" vibration events impacting a residential use (i.e., fewer than 30 vibration events from the same source per day, which is typical of most commuter rail vibration sources), the vibration assessment shall recommend measures to reduce vibration levels to 72 VdB or less. Examples of such measures that have been very successfully used, separately or in combination, to avoid vibration impacts to other residential projects located near rail transit vibration sources include:

- Building Foundation Mats – the use of increased mass in the foundation of the building to increase the effective vibration reduction that occurs at the boundary between the soil and the building foundation structure.

- Vibration Isolation – after provision of a break or gap in the structure between the first floor concrete slab and the top of the basement walls/columns, isolation would be achieved by placing rubber pads between the top of the basement walls/columns and the first floor structure.

Recommend vibration reduction measures provided by the site-specific assessment shall be incorporated into the design and construction of the proposed infill development project and their effectiveness shall be verified by vibration monitoring measurements after construction. The applicant shall provide the Department of Building and Safety documentation demonstrating compliance with this measure for review and approval once construction has been completed, but prior to occupancy of the building(s).

6. For projects that cover areas **greater than 5 acres**, applicants shall provide appropriate analysis and modeling for CO, NO_x, PM₁₀ and PM_{2.5}.
7. For **industrial projects located within 1,000 feet of a residential land use**, applicants shall complete a noise study using the significance thresholds established in the City of Los Angeles CEQA Thresholds Guide. Identified impacts shall be mitigated per the City's Noise Ordinance.