

Los Angeles Department of City Planning

PACIFIC PALISADES

Commercial Village and Neighborhoods



Specific Plan

August 7, 2016

TABLE OF CONTENTS

1. Specific Plan	
Boundary Map	I
2. Sections	1
Section 1. Establishment Of The Pacific Palisades Commercial Village and Neighborhoods Specific Plan	1
Section 2. Purposes. :	1
Section 3. Relationship to Other Provisions of the Municipal Code	2
Section 4. Definitions	3
Section 5. Prohibitions And Exceptions	5
Section 6. Land Use	6
Section 7. Height	7
Section 8. Floor Area Ratio	7
Section 9. Setbacks	8
Section 10. Parking	8
Section 11. Alcohol Consumption Regulations	11
Section 12. Landscaping Standards and Urban Design Features	14
Section 13. Signs Standards	15
Section 14. Design Review and Standards	19
Section 15. Severability.	21
3. Appendix A	
Streetscape Design	A-1
4. Appendix B	
Master Sign Program	B-1

Specific Plan Boundary Map

Pacific Palisades Commercial Village and Neighborhoods Specific Plan



Map 1

Overview Map

Pacific Palisades Commercial Village and Neighborhoods Specific Plan

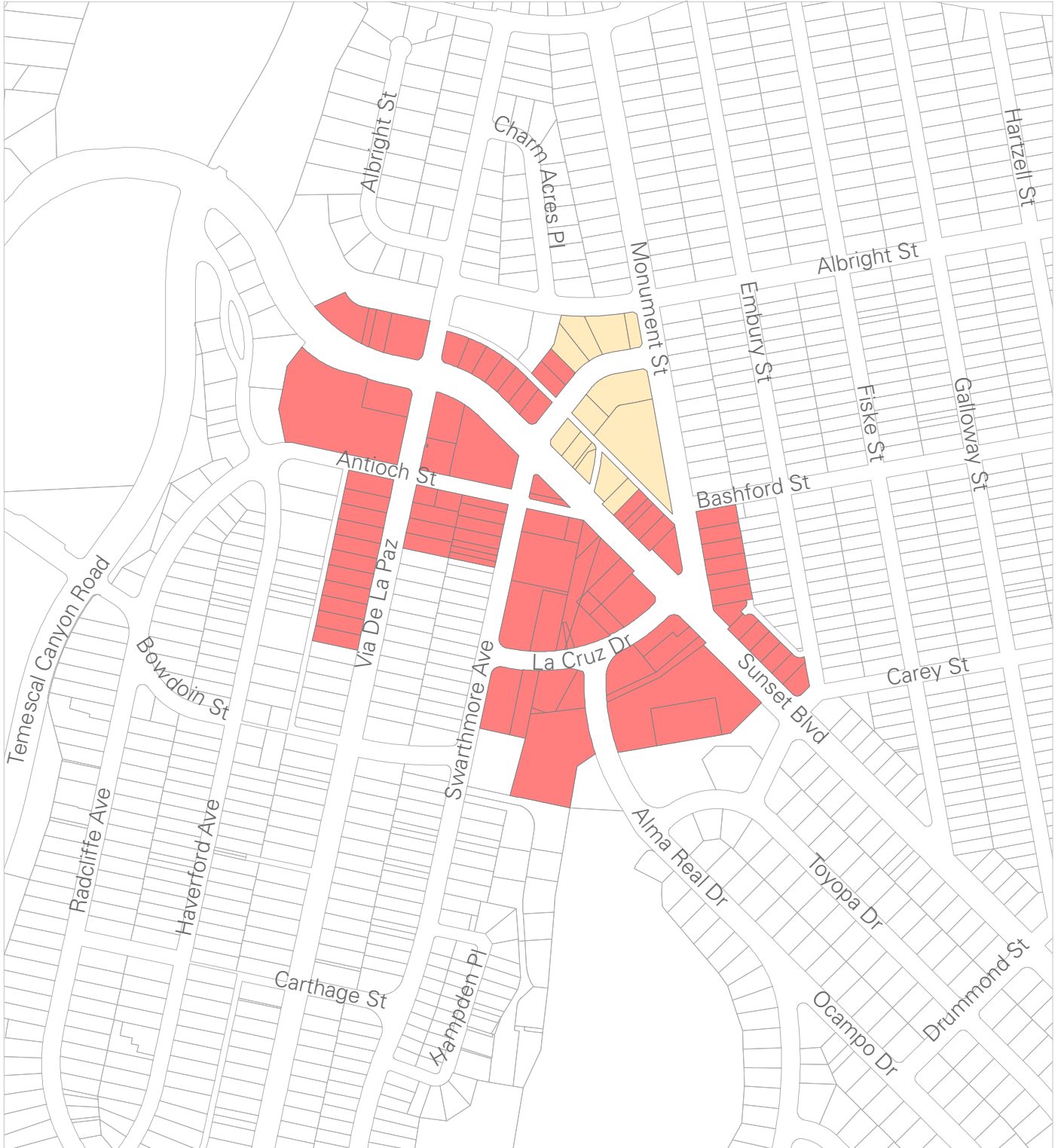

Legend

- Commercial Village Subarea A
- Commercial Village Subarea B

Map 2

Commercial Village

Pacific Palisades Commercial Village and Neighborhoods Specific Plan



Map 3: Neighborhood Area A

Pacific Coast Highway at Chautauqua Boulevard

Pacific Palisades Commercial Village and Neighborhoods Specific Plan



Map 4: Neighborhood Area B

Sunset Boulevard at Pacific Coast Highway

Pacific Palisades Commercial Village and Neighborhoods Specific Plan

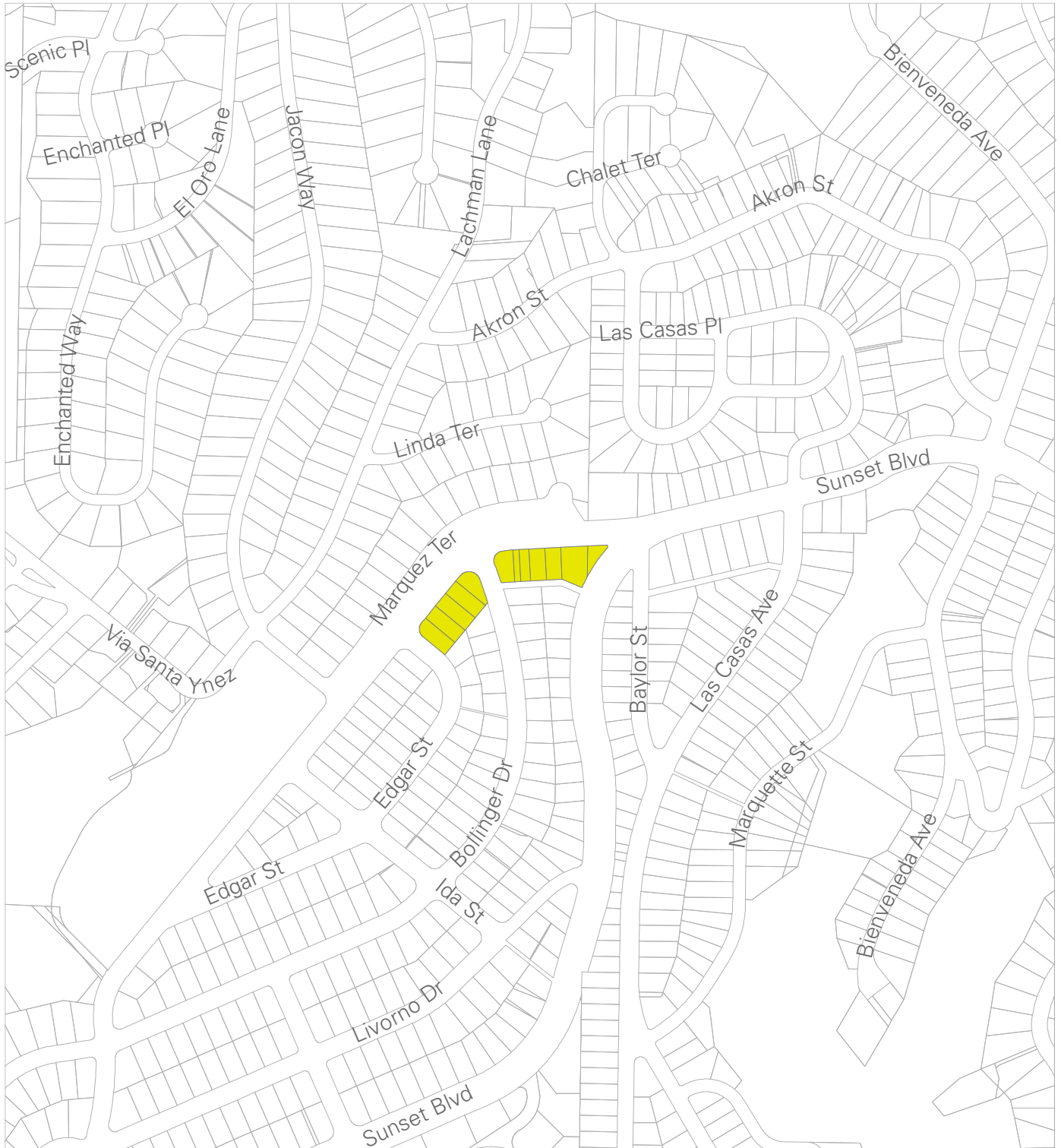

Map 5: Neighborhood Area C

Sunset Boulevard at Marquez Avenue

Sections

PACIFIC PALISADES COMMERCIAL VILLAGE AND NEIGHBORHOODS SPECIFIC PLAN

The people of the city of Los Angeles do ordain as follows:

Section 1.

ESTABLISHMENT OF THE PACIFIC PALISADES COMMERCIAL VILLAGE AND NEIGHBORHOODS SPECIFIC PLAN

The City Council hereby establishes this Pacific Palisades Commercial Village and Neighborhoods Specific Plan applicable to those areas of the City of Los Angeles shown within the shaded area on Maps 1 through 5.

Section 2.

PURPOSES. The purposes of this Specific Plan are as follows:

- A. To assure that the Pacific Palisades Commercial Village and Neighborhoods continue to function as significant commercial areas in the Pacific Palisades and that any future development is compatible with the surrounding residential community, the character of the commercial areas and the capacity of the circulation system as defined in the District Plan;
- B. To enhance the aesthetic qualities of development, protect the low intensity, community-oriented uses and preserve the individual qualities of the areas;
- C. To enhance the pedestrian-orientation of the business centers by reducing the size and location of signs within the Specific Plan Area; by promoting design coordination between a building or structure and its use; by removing temporary signs and clutter; by enhancing windows as display areas for merchandise; and by unifying the characteristics of each of the Specific Plan Areas through block signs, promotion banners and symbol signs;

- D. To assure that the commercial uses are consistent with the general character of the Pacific Palisades community, which consists of single-family residences, some multiple residential structures and significant open space and park-like development;
- E. To provide guidelines and a process for review and approval of exterior and site design, renovations, signs for buildings and structures and other developments;
- F. To promote orderly, attractive and harmonious development, minimize environmental effects of development, stabilize land values and investments and promote the general welfare by prohibiting buildings, structures or uses which are inconsistent with the purposes or standards of this Specific Plan or which are inappropriate to their sites, surroundings, traffic circulation impacts or their environmental setting;
- G. To adequately buffer all new development from nearby residential uses, to the greatest extent feasible;
- H. To assure that the character of Sunset Boulevard and Pacific Coast Highway conforms to the character of the Commercial Village and Neighborhoods because, although Sunset Boulevard and Pacific Coast Highway are links in the regional circulation system which is and always will be used by through commuter traffic, it is also “the front yards” of the Palisades Commercial Village and Neighborhoods and critical route for local vehicular and pedestrian traffic;
- I. To assure that development along Sunset Boulevard incorporates design characteristics that provide a unifying element to the Commercial Village and to each Neighborhood and enhances their status as scenic highways while providing a beautifying element to the Commercial Village and Neighborhoods through landscaping and other means.

Section 3.

RELATIONSHIP TO OTHER PROVISIONS OF THE MUNICIPAL CODE

- A. The regulations of this Specific Plan are in addition to those set forth in regulations of the Los Angeles Municipal Code (LAMC) and do not convey any rights not otherwise granted under such other provisions, except as specially provided herein.
- B. Wherever this Specific Plan contains regulations which conflict with regulations contained in LAMC Chapter 1, the Specific Plan shall prevail

and supersede the applicable provisions of that Code including those regulations contained in the Mini-mall regulation, Ordinance No. 164,201, the Commercial Corner regulations, Ordinance No. 175,223, related Sections of the LAMC for Alcohol Beverage Sales and the Site Plan Review regulations, Ordinance No. 164,951. Procedures for the granting of exceptions to the requirements of this Specific Plan are established in LAMC Section 11.5.7. In approving an exception to this Specific Plan, pursuant to Section 11.5.7, the City Planning Commission and the City Council on appeal may simultaneously approve any conditional use under their jurisdiction. Only one fee shall be required for joint applications.

Section 4.

DEFINITIONS

The following terms when used in this Specific Plan shall be construed as defined in this Section. Words and phrases not defined herein shall be construed as defined in LAMC Sections 12.03, 91.0403 and 91.6203, if defined therein.

Animated Sign: A sign which flashes or creates action, motion, or color changes requiring electrical, electronic or manufactured sources of energy supply.

Architectural Roof Features: Unique details and architectural components above the parapet or building's fascia, such as cupolas, dormers, towers, louvered vents, and mansard and pitched roofs.

Bench Sign: A sign painted on or otherwise attached to the back support or other portion of a public bench.

Block Directory Sign: A sign which lists all businesses for one side of all or part of a block.

Commercial Village: The area shown within the heavy black lines on Map 2.

Directional Sign: A sign designed to guide or direct pedestrian or vehicular traffic.

Financially-Oriented Services: Financial or real estate services provided to the public, including but not limited to those offered by banks, savings and loan associations, thrift associations, real estate offices, insurance companies, brokerage firms and escrow offices.

Ground Floor: The lowest story within a building which is accessible from the street, the floor level of which is within three feet above or below curb level, which has frontage on or is primarily facing any public street, and which is at least 30 feet in depth or the total depth of a building, whichever is less.

Ground Floor Retail: The sale of commodities to the public (as distinguished from wholesale sales not available to the public) and the provision of services, located on the ground floor of a building.

Height: The height of all building facades is limited to 30 feet and will be measured from adjacent sidewalk grade to the top of the parapet or roof fascia at the building perimeter. Only in Commercial Village Subarea A, the tallest point of architectural roof features of all buildings is limited to 34 feet, as measured from the adjacent sidewalk grade.

Identification Sign - Commercial Village and Neighborhoods: A sign at the entrance or exit of any of the Pacific Palisades Commercial Village or Neighborhoods' business districts.

Maps: The maps contained in this Ordinance (Maps 1 through 5).

Marquee Sign: A sign that is located on a marquee or a permanent roof structure attached to and supported by the building projecting over public property.

Medical and/or Dental Building: Any building or structure in which more than 30 percent of the floor area is devoted to the examination, diagnosis or treatment of physical or psychological disorders of out-patients.

Neighborhoods: Those outlying commercial areas shown within heavy black lines in Maps 3, 4 and 5.

Personal Services: Needed services provided to the public related to home, health or family such as dry cleaners, shoe repair and pharmacy and not including Financially-Oriented Services.

Project: The construction, erection, addition to or structural alteration of any building or structure, a use of land or change of use on a lot located in whole or in part within the Specific Plan Area which requires the issuance of a building permit, change of use permit or sign permit. A Project does not include a one-family dwelling or any interior remodeling of any building or structure, so long as the remodeling does not include a new use which is prohibited by Section 6 of this Specific Plan.

Public Access Way: Any public street, public right of way, pedestrian paseo, or vehicular alley drive that provides pedestrian access open to the public.

Sandwich Sign: A small, portable sign consisting of two sign faces connecting at the top and extending outward at the bottom of the sign and which is usually placed on a sidewalk or similar area.

Scenic Corridor: Any lot within the Specific Plan Area having a lot line contiguous to either Sunset Boulevard or Pacific Coast Highway.

Specific Plan Area: Those areas shown within the heavy black lines on the maps in this Ordinance (Maps 1 through 5).

Supermarket: A retail store which has a floor area equal to or greater than 5,000 square feet and which sells an assortment of foods, as well as items for food preparation, household cleaning and personal care.

Symbol Sign: A wooden sign attached to a wall or projecting from a wall identifying a use or service located on the site by symbol rather than words.

Temporary Sign: A sign posted for a limited duration, not to exceed 180 days, including paper signs and other signs that are not permanently affixed to the ground or building.

Window Sign: Any sign painted on or affixed to the transparent or translucent surface of a window or door and which is visible from outside the building or structure.

Section 5.

PROHIBITIONS AND EXCEPTIONS

- A. Prohibitions.** No building permit shall be issued for any Project unless the Project meets the requirements of Sections 6, 7, 8, 9, 10 and 11 of this Specific Plan as determined by the Department of Building and Safety and also meets the requirements of Sections 12, 13, and 14 of this Specific Plan as determined by the Director of Planning.

B. Exceptions

1. The provisions of this Ordinance shall not apply to any construction for which a building permit is required:
 - a. In order to comply with any order issued by the Department of Building and Safety to repair an unsafe or substandard condition; or
 - b. In order to rebuild as a result of destruction by fire, earthquake or other natural disaster, provided that the construction is not prohibited by any provision of the Los Angeles Municipal Code and the rebuilding does not increase the height or floor area of the destroyed building.
2. The provisions of this Ordinance shall not apply to the issuance of a building permit for a Project for which (a) architectural and structural plans sufficient for a complete plan check were accepted by the Department of Building and Safety on or before August 15, 1992; (b) a plan check fee was collected on or before August 15, 1992; and (c) no subsequent changes are made to those plans which increase the height or floor area by more than five percent.

Section 6.

LAND USE

A. Uses. In the Commercial Village and Neighborhood Areas B and C, lots zoned C2 may only be used for gas stations and all other uses permitted in the C4 Zone. In Neighborhood Area A, lots zoned [Q]C2-1XL are limited to C1 uses and gas stations, which are permitted only as a conditional use.

The following uses shall be prohibited in the Specific Plan Area:

1. automobile, recreational vehicle or bus-related uses, including automobile wash racks, used automobile and trailer sales, tire and battery servicing;
2. wholesale or retail businesses, except supermarkets, with a gross floor area of 25,000 square feet or more;
3. drive-in businesses in the Commercial Village and Neighborhood Areas A and C;
4. hotels and motels; and
5. trade schools and universities.

B. Ground Floor Retail. Each building in the Commercial Village and Neighborhood Areas shall have a Ground Floor. Ground Floor Retail uses shall occupy at least 75 percent of the linear frontage of the building along a public street in the Commercial Village and Neighborhood Areas. Day care and elementary school uses on the Ground Floor are exempt from this Ground Floor Retail requirement.

C. Mixed-Use Project. Residential uses may occupy the second story of any building so long as the building complies with the floor area requirement in Section 8 and the parking requirements in Sections 10 C 3 and 10 D of this Specific Plan.

Section 7.

HEIGHT

- A. Notwithstanding LAMC Section 12.21.1 B 3, no Project located in whole or in part within the Specific Plan Area shall exceed two stories or 30 feet in height. As defined in Section 4, in Commercial Village Subarea A, buildings with architectural roof features are limited to 34 feet in height.
- B. No Project shall exceed 27 feet in height, as measured from grade to the ceiling of the Project's upper story.

Section 8.

FLOOR AREA RATIO

The floor area ratio of any Project located in whole or in part within the Commercial Village shall not exceed 1.5:1, except that a mixed-use Project shall be permitted a floor area ratio of up to 2:1. However, if a mixed-use Project in the Commercial Village is permitted by a conditional use permit pursuant to LAMC Section 12.24 V 2, then this floor area ratio limitation does not apply.

The floor area ratio of any Project located in whole or in part within the Neighborhood Areas shall not exceed the following for each respective Neighborhood Area:

Neighborhood Area A: 0.5:1

Neighborhood Area B: 1.0:1

Neighborhood Area C: 0.75:1

If a mixed-use Project is permitted in the Neighborhood Areas by a conditional use permit pursuant to LAMC Section 12.24 V 2, then these floor area ratio limitations do not apply.

Gross lot area may be used to calculate allowable floor area ratio for any residential Project in the Neighborhood Areas and Commercial Village

Section 9.

SETBACKS

With the exception of Neighborhood Area A, any Project on a lot or lots located in whole or in part within the Specific Plan Area shall have a minimum setback of 2 feet from the sidewalk.

Section 10.

PARKING

A. *PB Zone.* Lots zoned PB (Parking Building) shall conform to the following:

1. Notwithstanding LAMC Section 12.21.1 B 3, no parking building shall exceed a height of 30 feet.
2. Parking buildings shall have a second-story setback of an additional ten feet from the perimeter of the first story.
3. Areas for parking vehicles in or on a building shall be completely screened from view, as seen from a public street.

B. *Parking Space Requirements.* Notwithstanding the requirements in LAMC Section 12.21, parking shall be provided as follows:

1. For dwelling units containing fewer than four habitable rooms or with a floor area of not more than 700 square feet, one parking space for each unit.
2. For dwelling units containing four or more habitable rooms or with a floor area of more than 700 square feet, two and a half parking spaces for each unit.
3. For retail, community rooms, and service commercial uses, one parking space for each 300 square feet of floor area.

4. Notwithstanding LAMC Section 12.21 A 4 (c) (3) for any restaurant, one parking space for each 100 square feet of floor area, except that for a fast-food restaurant, one parking space for each 75 square feet of floor area.
5. For general offices, one parking space for each 300 square feet of floor area.
6. For Medical and Dental Buildings, one parking space for each 125 square feet of gross floor area.
7. For Financially-Oriented Services, one parking space for each 300 square feet of gross floor area.
8. For movie theaters, one parking space for every four seats.
9. For high schools, seven parking spaces for each classroom or teaching station.
10. For elementary or junior high schools, four parking spaces for each classroom or teaching station.
11. For child care and preschool, one parking space for each staff member and one parking space for each eight children.
12. For gyms, aerobic dance studios, health clubs or similar uses, one parking space for each 100 square feet of gross floor area.

Where additions to existing buildings or structures are 500 square feet or less, the above requirements shall apply only to the addition. For additions of more than 500 square feet, these parking requirements shall apply to both the existing building or structure and the addition.

C. Off-site Parking

Notwithstanding the distance limitations set forth in LAMC Section 12.21 A 4 (g), required parking may be provided anywhere within the Specific Plan Area, so long as the Director of Planning and the Department of Transportation have approved the off-site parking. However, the following regulations shall apply:

1. The off-site parking shall comply with the requirements of Section 10 B of this Specific Plan.
2. The off-site parking shall comprise no more than 25 percent of the number of required parking spaces.
3. No off-site parking shall be permitted to meet the parking requirements for residential dwelling units.

D. Provisions for Bicycle Parking

Notwithstanding LAMC Section 12.21 A 16, bicycle parking in conformance with the following requirements shall be provided for all Projects consisting of new buildings or structures or additions to existing buildings where the additions add more than 500 square feet of floor area:

1. Bicycle parking shall be provided in an area equivalent to one percent of the floor area of a Project or at a ratio of two bicycle parking stalls per 1,000 square feet of floor area of the building or structure, whichever is less.
2. These bicycle parking spaces shall be located as close to the front entrance of the building or structure as possible and not within the sidewalk right-of-way.
3. For theaters, there shall be bicycle parking spaces equal to 30 percent of the automobile parking spaces required by this Specific Plan.
4. In Commercial Village Subarea A, bicycle parking shall be pursuant to LAMC Section 12.21 A 16.

E. On-site Parking and Driveway Access, Proposed Development

Prior to the issuance of a design review approval by the Director of Planning, the applicant shall submit plans to the Department of Transportation for its review as to the adequacy of the design of parking lots, their relationship to the buildings or structures they serve and the number and placement of driveways.

1. Left turns from or into driveways providing access to Sunset Boulevard shall be minimized as determined by the Department of Transportation in accordance with LAMC Section 80.14.
2. Wherever possible, driveway access shall be from any street or alley, other than from Sunset Boulevard.

Section 11.

ALCOHOL CONSUMPTION REGULATIONS— COMMERCIAL VILLAGE SUBAREA A

The sale and service of alcoholic beverages for on-site and off-site consumption shall be permitted within Commercial Village Subarea A as provided below. Entities that sell and serve alcoholic beverages for on-site and off-site consumption shall obtain approvals from other jurisdictions, as required, including licenses or permits from the State Department of Alcoholic Beverage Control (ABC). A maximum total of eight (8) Alcohol Use Approvals (including on-site and off-site) shall be permitted.

A. Alcohol Use Approvals for Alcoholic Beverage Sales for On-Site Consumption. Except as set forth below and notwithstanding Chapter 1 of the LAMC, the application for the sale and service of alcoholic beverages for on-site consumption shall be processed pursuant to the procedures in LAMC Section 12.24 M under the authority of the Director of Planning, subject to the following:

- 1. Number of Establishments.** A maximum total of six (6) on-site establishments are permitted within Commercial Village Subarea A after the effective date of this Specific Plan, as follows:
 - a. One (1) approval for the on-site sale and consumption of a full line of alcoholic beverages within a theatre;
 - b. Five (5) approvals for the on-site sale and consumption of a full line of alcoholic beverages in conjunction with restaurants;
 - c. The number of establishments listed above may be adjusted within each category, provided that the total number of licensed premises does not exceed 6, and subject to a Plan Approval pursuant to LAMC Section 12.24 M.
- 2. Application for Permit.** To apply for an Alcohol Use Approval, an applicant shall file an application with the Department of City Planning pursuant to LAMC Section 12.24 B.
- 3. Conditions.** The Director of Planning, through the Alcohol Use Approval process, shall review applications for compliance with LAMC Section 12.24 F.
- 4. Findings.** Findings shall be made pursuant to LAMC Section 12.24 W.1(a).

5. **Public Hearing.** At the discretion of the Director of Planning a public hearing may be held on an On-Site Alcohol Use Approval application if the application is likely to be controversial. If a public hearing is conducted, procedures shall be followed pursuant to LAMC Section 12.24 D.
6. **Time to Act.** Time to Act for Alcohol Use Approvals shall follow procedures in LAMC Section 12.24.G—H.
7. **Appeals.** Any appeal filed from a Director of Planning’s Determination shall be processed pursuant to the provisions and procedures set forth in LAMC Section 12.24 M.
8. **Discontinuance of Use.** Notwithstanding LAMC Section 12.24 Q to the contrary, the 6 Alcohol Use Approvals permitted by this Specific Plan shall continue through the life of the Specific Plan. If an Alcohol Use Approval for a given establishment is abandoned, or is discontinued for a continuous period of one year, it may not be re-established unless authorized in accordance with the procedure prescribed in Section 11.A. of the Specific Plan.
9. **Revocation.** If the conditions of this Subsection have not been complied with, the City may give notice to the property owner or lessee of the real property affected to appear at a time and place fixed by the City and show cause why the use permitted by this Subsection should not be modified, discontinued or revoked. These proceedings shall be in accordance with LAMC Section 12.24 Z.

B. Alcohol Use Approvals for Alcoholic Beverage Sales for Off-Site Consumption. All off-sale alcohol uses, including renewals of existing conditional uses and the establishment of new conditional uses in the Commercial Village Subarea A, shall be subject to review and decision by a Director of Planning.

1. **Number of Establishments.** A maximum total of two (2) Alcohol Use Approvals shall be allowed for sale of a full-line of alcohol beverages for off-site consumption within Commercial Village Subarea A, after the effective date of this Specific Plan, as follows:
 - a. One (1) approval for the off-site consumption of a full line of alcoholic beverages in conjunction with a specialty retail use;
 - b. One (1) approval for the off-site consumption of a full line of alcoholic beverages in conjunction with market.

- c. The number of establishments listed above may be adjusted within each category, provided that the total number of licensed premises does not exceed 2, and subject to a Plan Approval pursuant to LAMC Section 12.24 M.
2. **Application for Permit.** To apply for an Alcohol Use Approval an applicant shall file an application with the Department of City Planning pursuant to LAMC Section 12.24 B.
 3. **Conditions.** The Director of Planning, through the Alcohol Use Approval process, shall review applications for compliance with LAMC Section 12.24 F.
 4. **Findings.** Findings shall be made pursuant to LAMC Section 12.24 W.1(a).
 5. **Public Hearing.** Public Hearing. At the discretion of the Director of Planning a public hearing may be held on an Alcohol Use Approval application involving an establishment seeking off-site consumption if the application is likely to be controversial. If a public hearing is conducted, procedures shall be followed pursuant to LAMC Section 12.24 D.
 6. **Time to Act.** Time to Act for Alcohol Use Approvals shall follow procedures in LAMC Section 12.24 G—H.
 7. **Appeals.** Any appeal filed from a Director of Planning’s Determination shall be processed pursuant to the provisions and procedures set forth in LAMC Section 12.24 M.
 8. **Discontinuance of Use.** Notwithstanding LAMC Section 12.24 Q to the contrary, the 2 Alcohol Use Approvals permitted by this Specific Plan shall continue through the life of the Specific Plan. If an Alcohol Use Approval for a given establishment is abandoned, or is discontinued for a continuous period of one year, it may not be re-established unless authorized in accordance with the procedure prescribed in Section 11.A. of the Specific Plan.
 9. **Revocation.** If the conditions of this Subsection have not been complied with, the City may give notice to the property owner or lessee of the real property affected to appear at a time and place fixed by the City and show cause why the use permitted by this Subsection should not be modified, discontinued or revoked. These proceedings shall be in accordance with LAMC Section 12.24 Z.

Section 12.

LANDSCAPING STANDARDS AND URBAN DESIGN FEATURES

A. Street Trees

Street trees shall conform to the City's street tree requirements and shall be approved by the Department of Public Works and the Director of Planning. Unless determined to be infeasible by the Department of Public Works, street trees shall be placed at least 30 feet apart and no more than ten feet from the curb. The minimum size for street trees shall be ten feet in height and 2 inches in caliper.

B. Entrances to Courtyards and Walkways

Landscaping which includes grouping of plant materials, consisting of small trees, shrubs, planter boxes or tubs of flowers, shall be placed at entrances to courtyards and along walkways.

C. Side Yard Areas

Side yard areas shall be landscaped using plant materials similar to those used in the front yard of a Project. Where side yards include entrances to buildings or structures, the entrances shall be subject to Subsection B above.

D. Buffering

There shall be a buffer of plant material satisfactory to the Director of Planning wherever a commercially zoned lot is adjacent to or abutting the side or rear yard of a residentially zoned or residentially used lot within the Specific Plan Area. The plant material shall be maintained to a height not exceeding eight feet and shall not be less than 6 feet at maturity. If a plant material is not feasible for the buffer as determined by the Director of Planning, then a 6-foot high decorative masonry wall shall be utilized as a buffer.

A landscaped buffer shall also be provided between parking buildings and adjacent residential areas.

E. Parking Lots

At least five percent of the total area of an at-grade, open parking lot within the Specific Plan Area shall be landscaped with plant material, and at least half of the landscaped area shall be planted with evergreen, shade-producing trees no less than 10 feet in height at planting.

F. Landscaping of Parking Buildings

Landscaping, visible from the street, shall be provided on each floor of a parking building to the satisfaction of the Director of Planning.

G. Landscape Maintenance

It shall be the responsibility of the property owner to maintain all landscape and hardscape features located on private property, including, but not limited to, plant material, signs, walkways, benches and fountains in accordance with the following criteria:

1. All fabricated features shall be maintained in good condition both in structural integrity and cosmetic appearance, and
2. All vegetation shall be watered, fertilized, trimmed and maintained in a good condition.

H. Metal Awnings and Bars on Windows

Metal awnings attached to any part of a building or structure are prohibited.

Metal bars at the front of any window are prohibited unless approved by the Director of Planning, after recommendations, if any, from the Design Review Board pursuant to standards established in Section 14 of this Specific Plan. Metal bars shall only be located on the inside of a window and only when permitted under the City's building and fire codes.

I. Underground Utilities

Where feasible, when a new building or structure is developed within the Specific Plan Area, utility connections shall be placed underground.

Section 13.

SIGNS STANDARDS

A. Prohibitions. The following signs are expressly prohibited:

1. Off-site commercial signs.
2. Roof signs.
3. Window Signs (except store names, store hours, logos and holiday paintings which must be removed within five business days after the holiday).
4. Animated signs, including flashing neon signs.

5. Bench Signs.
6. Pole signs and monument signs (except as provided in Subsection C of this Section).

B. Requirements. All signs, except as provided in Subsections C and D of this Section, shall conform to the following criteria:

1. The total sign area shall not exceed two square feet for each of the first 20 feet of building frontage which is adjacent to a public access way and one square foot for each linear foot of building frontage which exceeds the first 20 feet.
2. Where buildings or structures occupy a corner site, total sign area shall be 1.5 times the building frontage. For such corner locations, no more than two-thirds of the total allowable sign area shall be permitted facing on any one of the street frontages.
3. For all buildings occupied by several businesses or uses, the size of signs pertaining to each business or use is governed by the proportion of the building frontage occupied by that business or use.
4. Where there is a public entrance from an alley or from a parking lot in addition to the main entrance, there shall be permitted an additional sign area of one-half square foot for each linear foot on that side of the lot, not to exceed 20 square feet in area. If there is no public entrance on that side of the building, sign area is limited to a business identification sign, not to exceed two square feet in sign area.
5. No single sign shall exceed 100 square feet in sign Area.
6. With the exception of Commercial Village Subarea A, marquee signs and signs attached to awnings may not project above the marquee or awning; may not extend more than 12 inches below the marquee or awning; and shall be at least eight feet above the sidewalk or ground. In Commercial Village Subarea A, a marquee sign may not exceed 200 square feet of sign area per face and may project outward from a building. Such sign shall not be located lower than eight feet above grade and may not exceed 30 feet in height above the adjacent sidewalk grade.
7. One Symbol Sign shall be permitted for each business or use and is not included in aggregate size limits. A Symbol Sign may not exceed three square feet in total area and must project from the building or structure or wrought iron brackets of uniform size established by the Design Review Board.

8. Notwithstanding Subsections (c), (d) and (e) of LAMC Section 62.132 banners shall only be permitted if (a) the banner is hung on a 4-foot flag pole; (b) it is attached to the front of a building or structure; and (c) there is clearance of at least 12 feet above the adjacent grade. Banners shall be a uniform size of four by two and one-half feet and may not be displayed for more than 30 days.
9. All signs, other than those described in Subdivisions 6, 7, 8 and 10 of this Subsection shall be parallel to building walls or facades.
10. Temporary Signs inside a building and visible from the outside shall be set back at least six inches from a window and may not be displayed for more than 30 days. The total sign area of such sign shall not exceed 20 percent of the total square footage of the window.
11. No sign shall be attached directly to either the inside or outside of any window or door, except for store names, store hours and logos.
12. Any store hours sign shall be placed in the front door or window closest to the front door. Such sign shall not exceed three square feet in sign area.
13. All signs located in Commercial Village Subarea A shall comply with the Master Sign Program provided in Appendix B of this Specific Plan. Signs conforming to Appendix B shall be eligible for Administrative Clearance pursuant to LAMC Section 12.32 S.4. All other signs shall be subject to LAMC Sections 11.5.7 and 16.50.

C. Gas Station Sign Requirements

1. In addition to one wall sign, a gas station may have one monument sign or one pole sign. A pole sign for a gas station shall not exceed the height of the roof line of the station or eight feet in height from ground level, whichever is less.
2. No gas station pole or monument sign shall exceed 36 square feet of sign area including all faces of a multi-faced sign, and shall be placed in a permanently landscaped area of no less than 24 square feet surrounded by a concrete curb of no less than six inches and no more than 12 inches in height.
3. A double-faced sign shall be used to advertise the price of gasoline. The sign area of such sign shall not exceed nine square feet on each side, shall be hung beneath the canopy of the station and shall not extend more than four feet beneath the canopy.

4. One additional sign may be used to advertise services offered by the gas station. Such sign shall be single-faced, not more than 12 square feet in total sign area, shall be attached to the building, and shall not extend above the roof of the building to which it is attached.

D. Exceptions. The provisions of this Section shall not apply to:

1. Any sign required by law or by a governmental agency, except for gas station signs.
2. Any real estate sign which pertains to rent, lease or sale of property only and has a sign area which does not exceed 18 by 25 inches.
3. Any Block Directory Sign which has been approved by the Director of Planning.
4. Any traffic direction and parking information sign in the Commercial Village and Neighborhood Areas which has been approved by the Director of Planning.
5. Any mural which has been approved by the Cultural Affairs Commission of the City and has been reviewed and approved by the Director of Planning pursuant to Section 14 of this Specific Plan.
6. Any time and temperature sign, provided no advertising is included.
7. Any sign advertising the sale or lease of a vacant lot provided it has been approved by the Director of Planning and complies with the following conditions:
 - a. The sign shall not be illuminated.
 - b. The total sign area shall not exceed nine square feet.
 - c. The sign shall not exceed a height of six feet above the ground level or adjacent sidewalk.
 - d. The sign shall be located not less than ten feet from the lot line.
8. Any temporary construction sign located on a lot where a building or structure is being erected or remodeled and which identifies the owner, architects, engineers, financing agent and/or contractors involved in the Project; provided the sign shall not be more than 40 square feet in total sign area nor extend more than eight feet issuance of a certificate of occupancy for the building or structure.

9. Any temporary political or other ideological sign, provided that the sign may not be a roof sign, may not exceed 20 square feet in sign area and 10 feet in height, and if it relates to an election or other event is removed within 15 days following the election or event to which it relates.
10. Any sign which identifies security protection systems, provided the sign does not exceed a sign area of 49 square inches.
11. Any flag.
12. Any Sandwich Sign, not otherwise prohibited by the LAMC, provided it does not exceed two feet by three feet in sign area, is no higher than 40 inches in overall height, is placed so as not to impede pedestrian traffic and is approved by the Director of Planning.
13. Any restaurant menu sign with a sign area of less than nine square feet.

E. Abatement of Nonconforming Signs

1. Any Window or Temporary Sign made non-conforming by reason of this Section shall be completely removed within 180 days following the effective date of this ordinance.
2. All other signs in the Commercial Village made nonconforming by this Section shall be completely removed within five years after the effective date of the original Pacific Palisades Commercial Village Specific Plan ordinance (December 31, 1985), except for a sign or structure which qualifies as an "advertising display" as defined in Section 5202 of the Business and Professions Code. This provision does not apply to Neighborhood Areas A, B and C unless a funding source is established for the purpose of reimbursing the owner of the sign. The effective date for these additional Areas would be that of this amendment (October 26, 1992) to the Specific Plan.

Section 14.

DESIGN REVIEW PROCEDURES

A. Jurisdiction. Except for one-family dwellings, the Director of Planning shall review plans, elevations and/or other graphic representations of each Project in accordance with the Design Review Board Procedures of Section 16.50 and the Specific Plan Procedures of Section 11.5.7 of the LAMC. The Pacific Palisades Commercial Village and Neighborhoods Design Review Board may make recommendations to the Director on design review matters.

The Director of Planning shall make a determination on design review based on the following standards:

1. All proposed buildings or structures shall be designed in such a fashion that all ventilation, heating or air conditioning ducts, equipment or other related appurtenances are adequately screened from public view;
2. Any exterior treatment of a building or structure including color, texture, windows or other architectural features shall be applied to all exterior walls in a similar manner;
3. Colors and types of building materials shall be reasonably consistent with the colors and types of building materials used in existing structures in each area and shall be harmonious with the character of each area;
4. The exterior building components, sun shading devices, lighting plan and fixtures shall be compatible with the general character of each area;
5. The proposed buildings or structures shall be designed, to the extent feasible, so as not to cast shadows on adjacent property;
6. Buildings and structures shall be oriented to maximize the potential for landscaped areas and public spaces and to minimize obstruction of mountain views;
7. The size of proposed buildings or structures shall be similar in scale to surrounding buildings or structures and shall be appropriate to the character of the areas;
8. All open areas not utilized for buildings, driveways, parking areas, recreational facilities or walks shall be landscaped so that multi-family or commercial uses are substantially buffered from the view of single-family dwellings;
9. Landscape design and plant types shall be compatible with the building design, site location, and the general character of each area.

B. The Pacific Palisades Commercial Village and Neighborhoods Design Review Board

1. ***Authority.*** The authority, duties, and review procedures applicable to the Pacific Palisades Design Review Board shall comply with Section 16.50 of the LAMC and the procedures in this Section.
2. ***Composition.*** The Pacific Palisades Commercial Village and Neighborhoods Design Review Board is hereby established, which shall consist of seven voting members. The voting members shall be appointed by the Councilmember(s) of the District(s) encompassing the Specific

Plan Area and shall live or work in the Pacific Palisades, within zip code areas 90272 and 90402.

The board shall be constituted as follows:

- a. one member qualified in the discipline of architecture;
 - b. one member qualified in the discipline of landscape architecture;
 - c. one member qualified either in the discipline of urban planning or of landscape architecture;
 - d. four additional members.
3. ***Development of Design Guidelines.*** The Pacific Palisades Commercial Village and Neighborhoods Design Review Board shall propose and the City Planning Commission shall adopt specific design guidelines to implement provisions established in this Section. These guidelines may be illustrations, interpretations, standards or policies, and may address the color, materials, texture and/or design of features including but not limited to public signs, street furniture, trash containers, metal bars on windows and doors, traffic direction and parking information signs and exterior building facades. Departments or Commissions, under whose jurisdiction some of these matters lie, shall be requested to provide comments on these guidelines.
4. All applications for design review approval shall include approval by the Department of Transportation of on-site parking and driveway access plans in accordance with Section 10 E of this Specific Plan.

Section 15.

SEVERABILITY

If any provision of this Specific Plan or the application thereof to any person or circumstance is held to be unconstitutional or otherwise invalid by any court of competent jurisdiction, such invalidity shall not affect other specific plan provisions, clauses or applications thereof which can be implemented without the invalid provisions, clause or application, and to this end, the provisions and clauses of this ordinance are declared to be severable.

Appendix A: Streetscape Design

INTRODUCTION

The goal of Palisades Village is to seamlessly integrate the project into the existing commercial, residential and streetscape fabric of the Palisades.

Buildings will be sited within the project to create a strong street wall along Swarthmore Avenue and Sunset Boulevard. The project will incorporate mid-block pedestrian walkways which will include pedestrian level lighting, water features, landscaping and special paving. The existing service alley running parallel to Sunset Boulevard and perpendicular to Swarthmore has been maintained to service the project and the adjacent properties.

Large sidewalk planting areas will be provided and maintained with lush, mature trees and plantings along the length of Swarthmore. Mature and healthy trees shall be maintained while unhealthy, damaged and existing street trees in poor condition will be replaced with mature specimen trees.

Drought tolerant, California native landscaping shall be utilized to limit irrigation needs and conserve water. Pedestrian promenades and plazas will incorporate permeable or porous paving materials to facilitate storm water capture and retention and to prevent runoff.











Figure A.1 - Proposed Streetscape Design



Swarthmore Avenue

Streetscape Improvements: Street Improvement Diagram

Diagram Key

-  Project Boundary
-  Vehicular Entry/Exit Point
-  Pedestrian Entry/Exit Point
-  Street Light
-  Pedestrian Oriented Street Light
-  Existing Crosswalk
-  New Crosswalk
-  Bus Stop

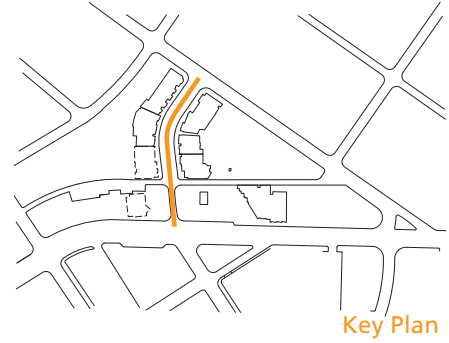

Traffic Flow

One-way traffic from Service Alley to Monument Street

On-Street Parking

Diagonal Parking
Provided on both Sides of Street

Existing Buildings

Not a Part of Project

Existing Buildings

Not a Part of Project

New Buildings

One and Two Story Pedestrian Oriented Buildings

Pedestrian Promenade

Provides Access to Interior Oriented Retail & New Public Park

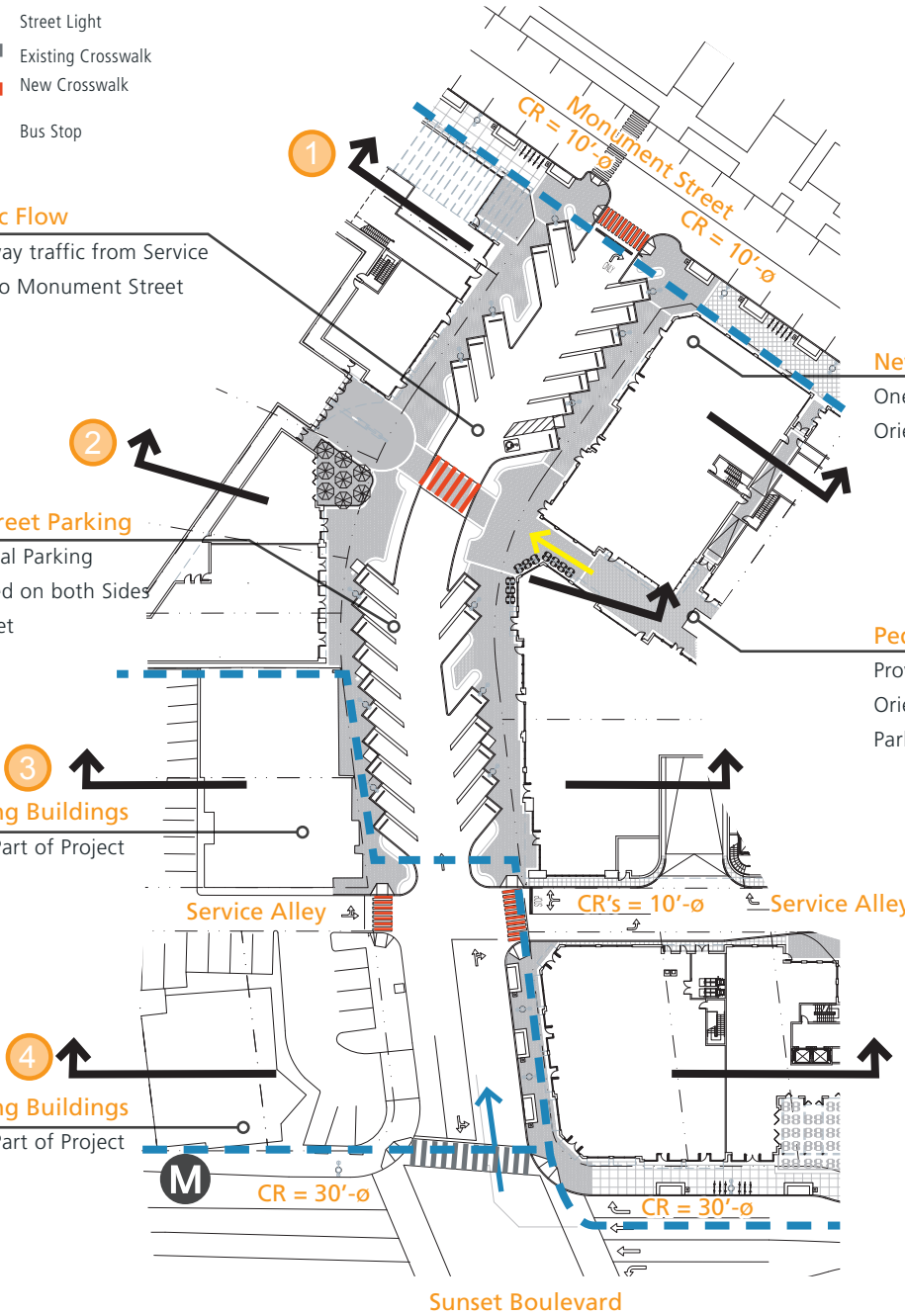

Swarthmore Avenue

Streetscape Improvements: Street Sections

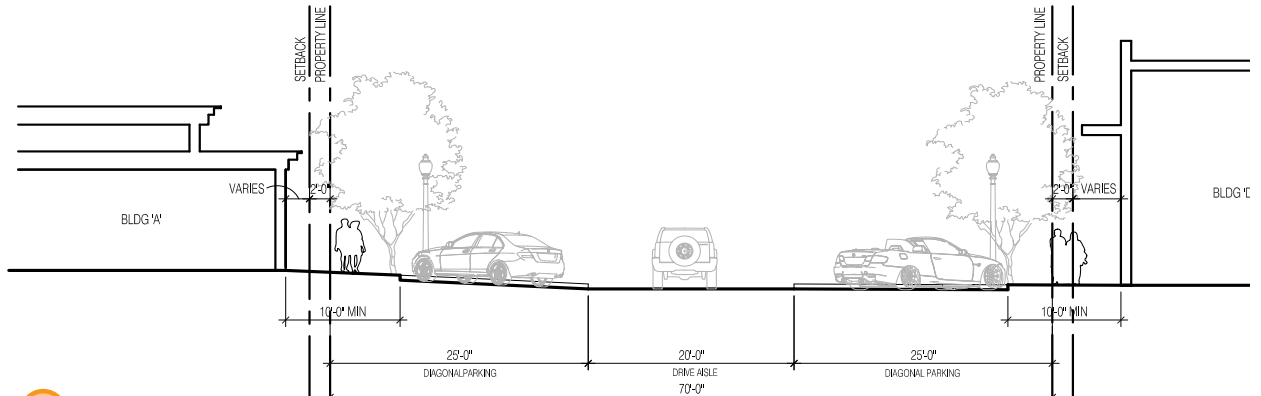

1 Swarthmore Avenue Near Intersection of Monument Street

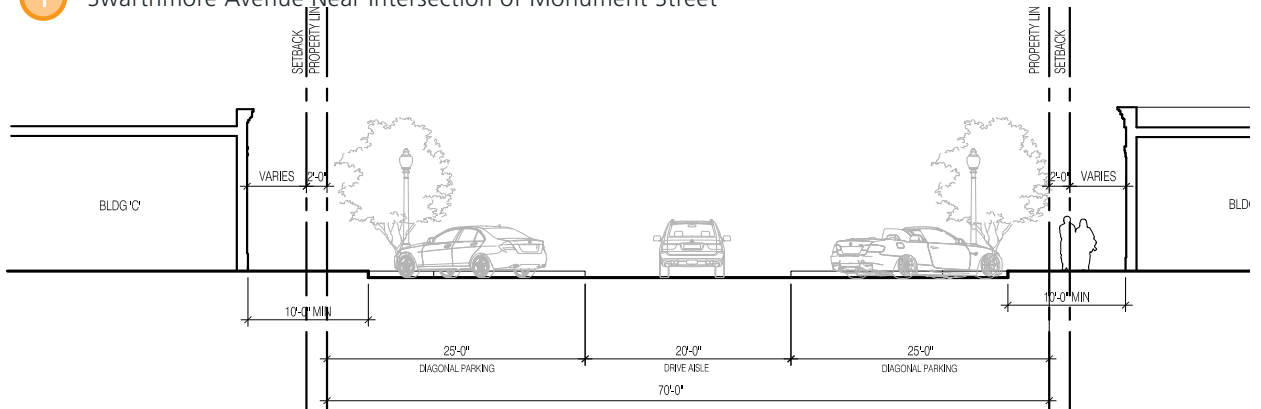

2 Swarthmore Avenue Near Pedestrian Entry

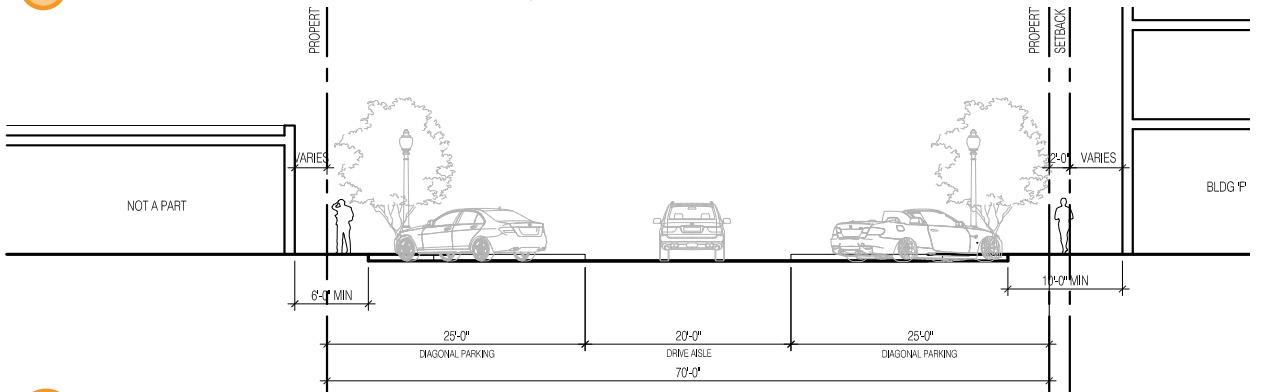

3 Swarthmore Avenue Near Intersection of Service Alley

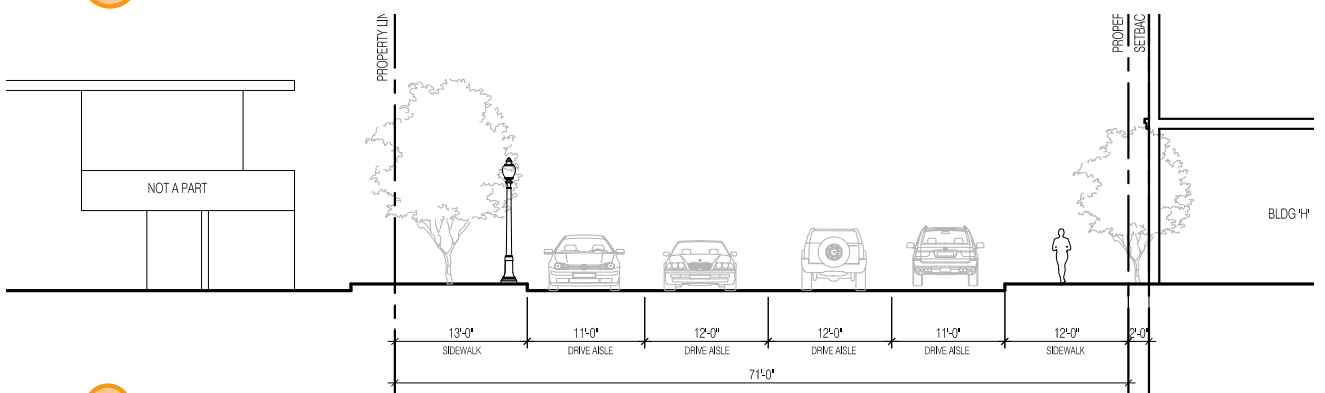

4 Swarthmore Avenue Near Intersection of Sunset Boulevard

Swarthmore Avenue

Streetscape Improvements: Street Paving Plan

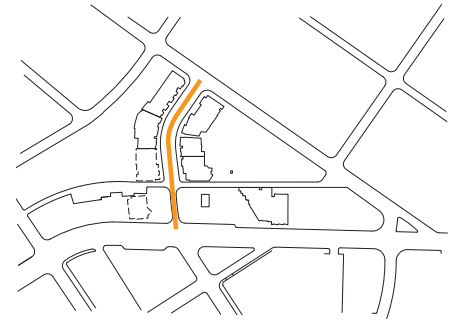

Key Plan

Sidewalk Paving

Brick; Herringbone Pattern

Cinema Plaza Paving

Brick Pavers

Sidewalk Easement

Line dotted of 6 feet clear, unobstructed pedestrian route on sidewalk on Public Right of Way and private land within project property line with appropriate Easement to ensure protection of route

On-Street Parking

Diagonal Parking Provided on both Sides of Street

Pedestrian Lighting

Sidewalk mounted luminaire & pole

Sidewalk Paving

Brick; Herringbone Pattern

Sidewalk Paving

Concrete



Sidewalk Corner

Brick Paving

Pedestrian Lighting

Sidewalk mounted luminaire & pole

Pedestrian Crosswalk

Brick Paving

Street Paving

Asphalt; Concrete curb & gutter

Sidewalk Paving

Brick; Herringbone Pattern

Sidewalk Easement

Line dotted of 6 feet clear, unobstructed pedestrian route on sidewalk on Public Right of Way and private land within project property line with appropriate Easement to ensure protection of route

Sidewalk Paving

Brick; Herringbone Pattern



Sunset Boulevard

Swarthmore Avenue

Streetscape Improvements: Street Planting Plan



Sidewalk Trees

Pyrus Trees (Aristocrat Pear) in 5' x 5' Well

Ground Plantings & Shrubbery

Buxus Edging, Creeping Thyme, Penstemon, Hamerocallis, Agapantha, Heliotrope, Diets Iriodes

Sidewalk Trees

Pyrus Trees (Aristocrat Pear) in 5' x 5' Well



Sunset Boulevard

Streetscape Improvements: Street Diagram and Paving Plan

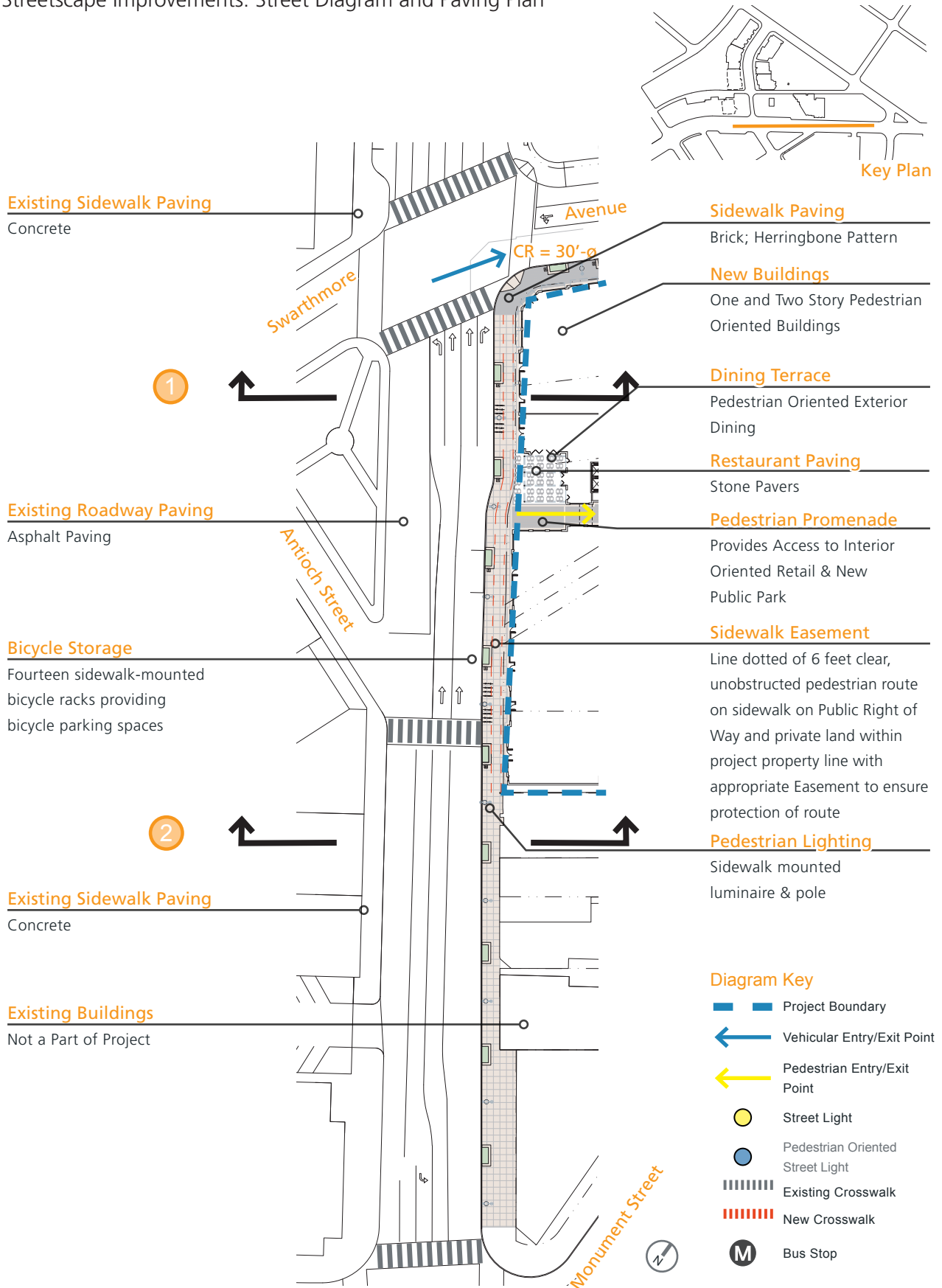

Sunset Boulevard

Streetscape Improvements: Street Sections

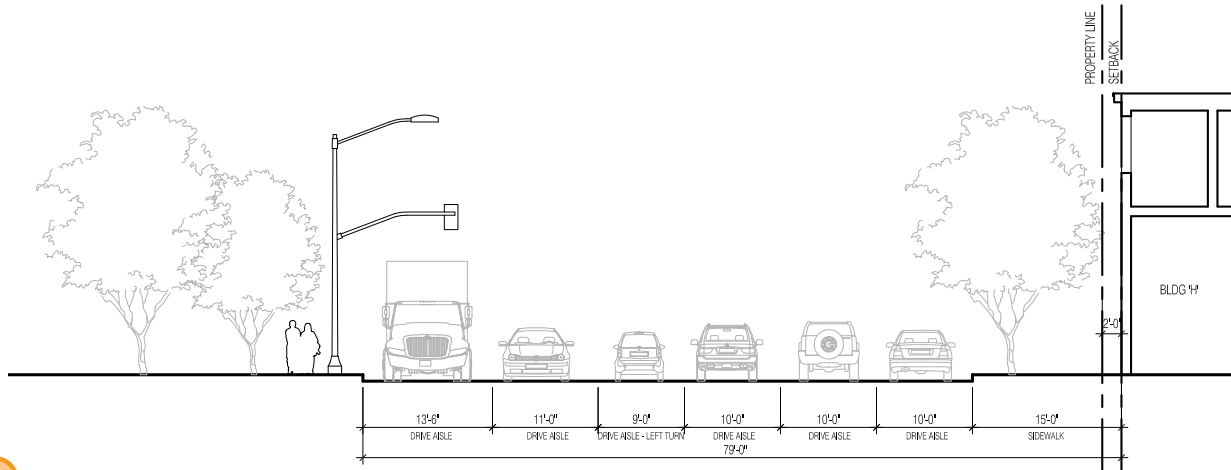

1 Sunset Boulevard Near Pedestrian Entry

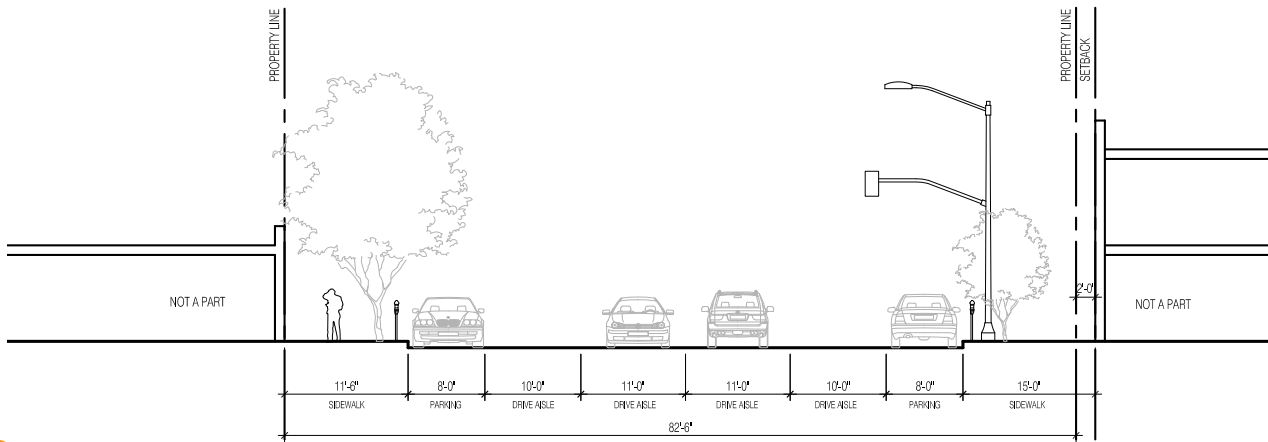

2 Sunset Boulevard Near Intersection of Service Alley

Sunset Boulevard

Streetscape Improvements: Street Planting Plan

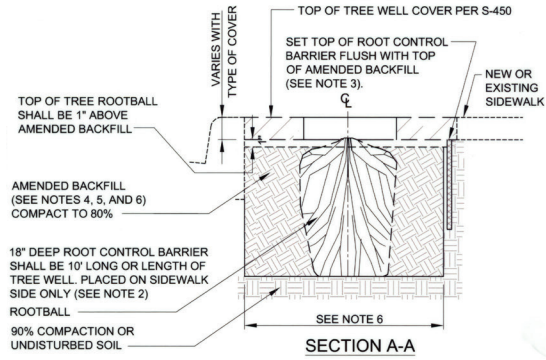

Sidewalk Trees

Koelreteria Trees (Chinese Flame)
in 5' x 5' Well

Ground Plantings & Shrubbery

Boxwood Edge Border

Sidewalk Trees

Koelreteria Trees (Chinese Flame)
in 5' x 5' Well



Monument Street Streetscape Improvements: Street Diagram

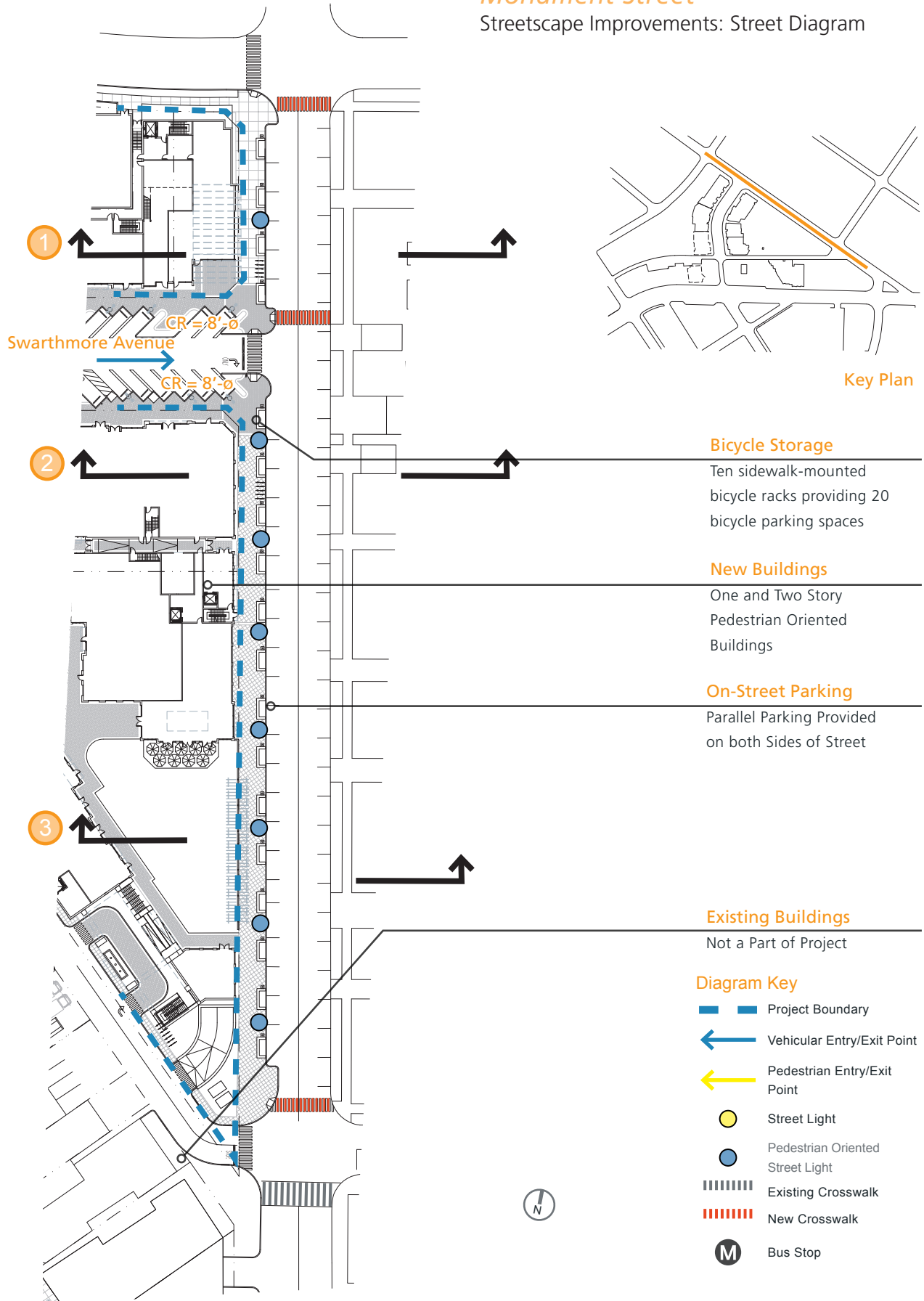

Monument Street

Streetscape Improvements: Street Sections

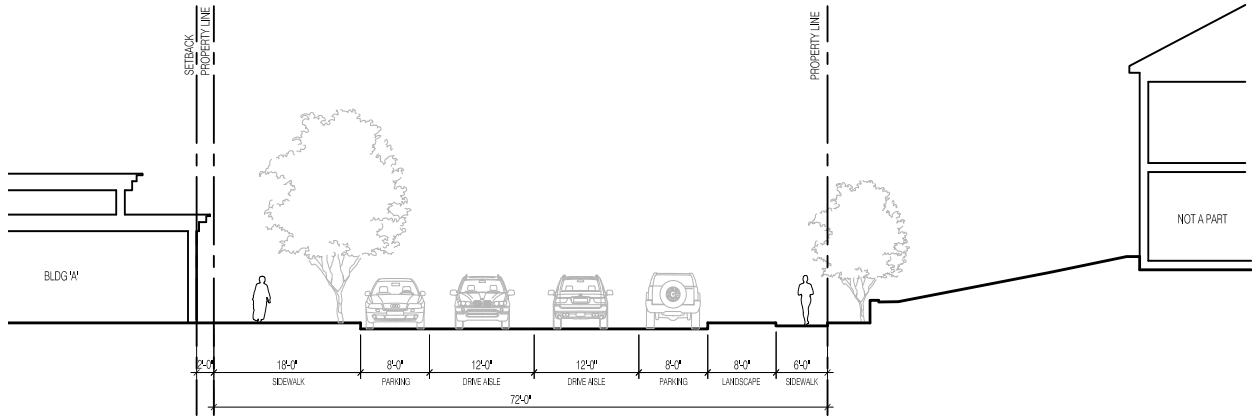

1 Sunset Boulevard Near Intersection of Albright Street

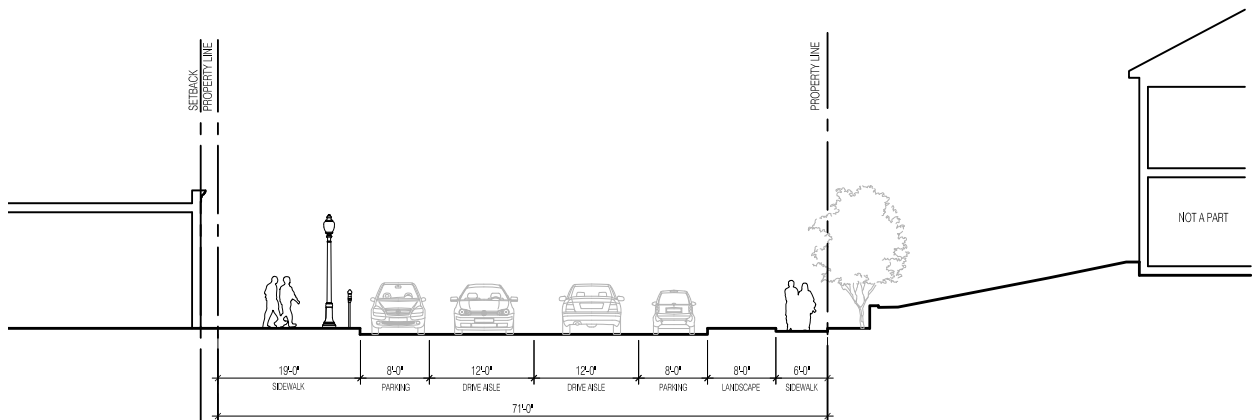

2 Sunset Boulevard Near Intersection of Swarthmore Avenue

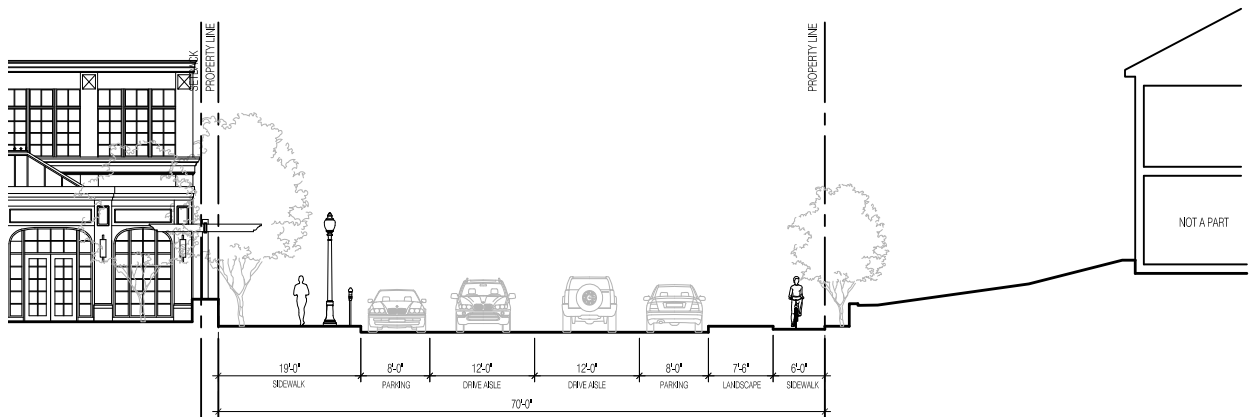

3 Sunset Boulevard at Parking Lot

Monument Street

Streetscape Improvements: Street Paving Plan

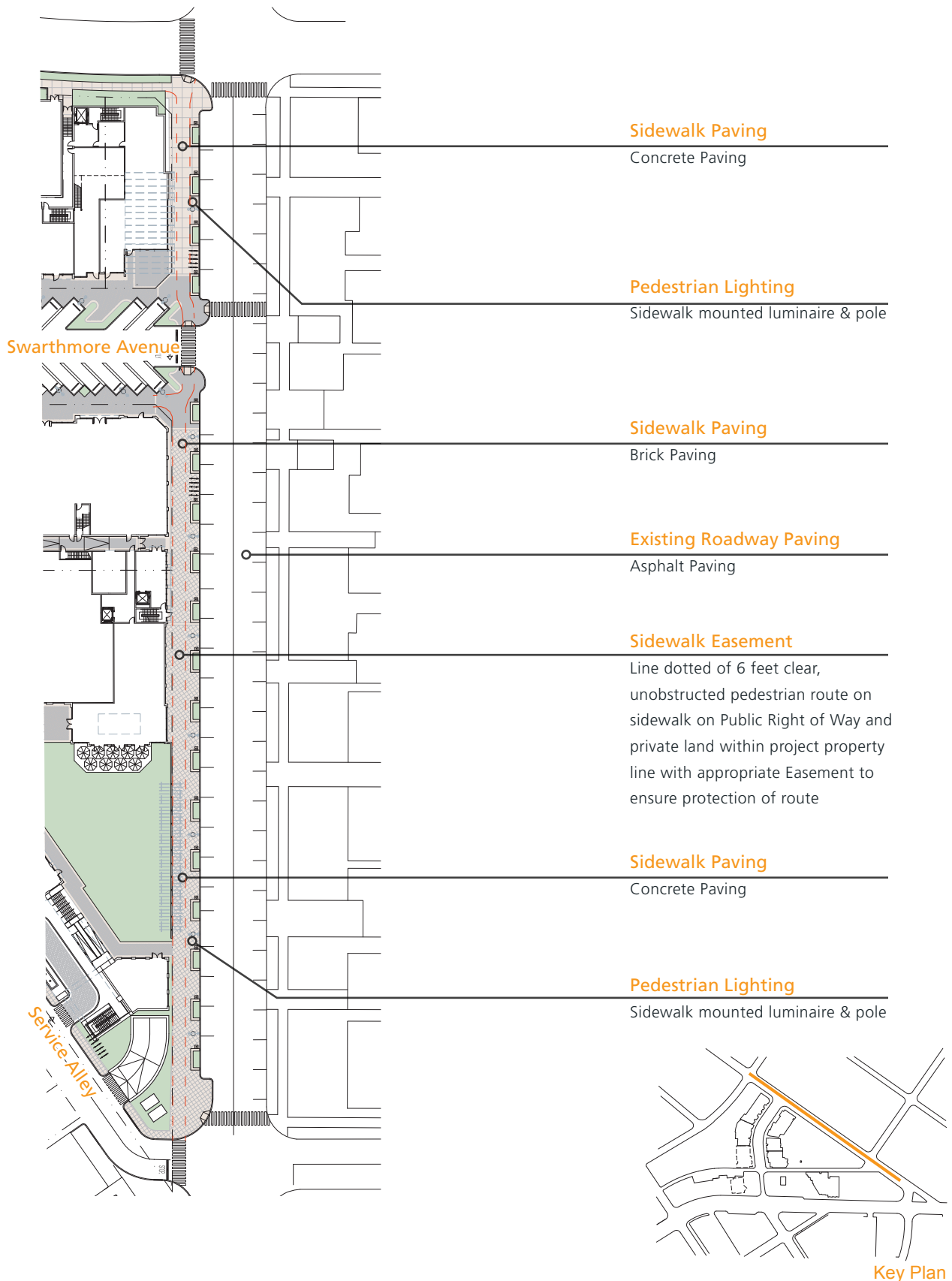

Monument Street

Streetscape Improvements: Street Planting Plan

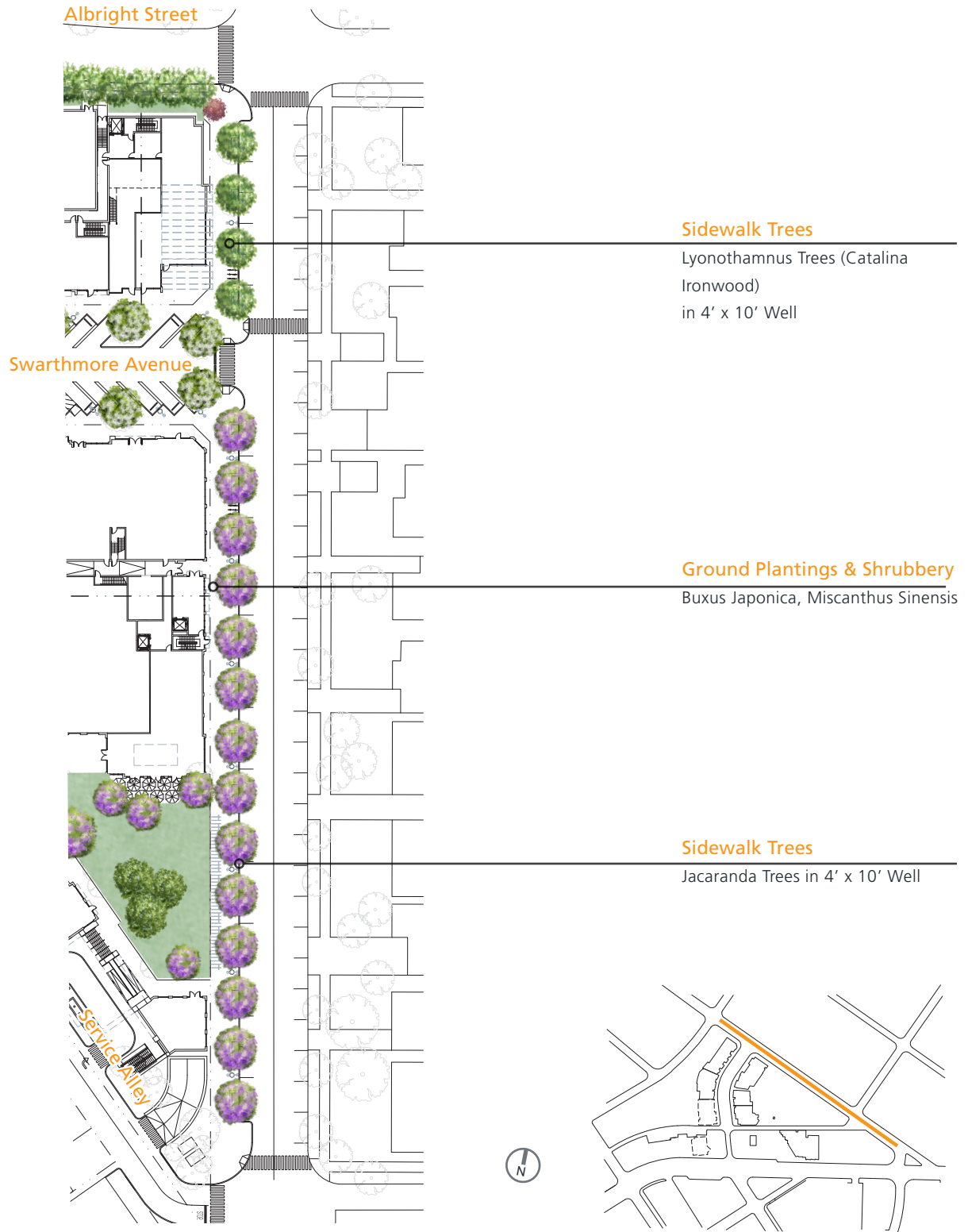

Albright Street

Streetscape Improvements: Street Diagram and Paving Plan



Key Plan

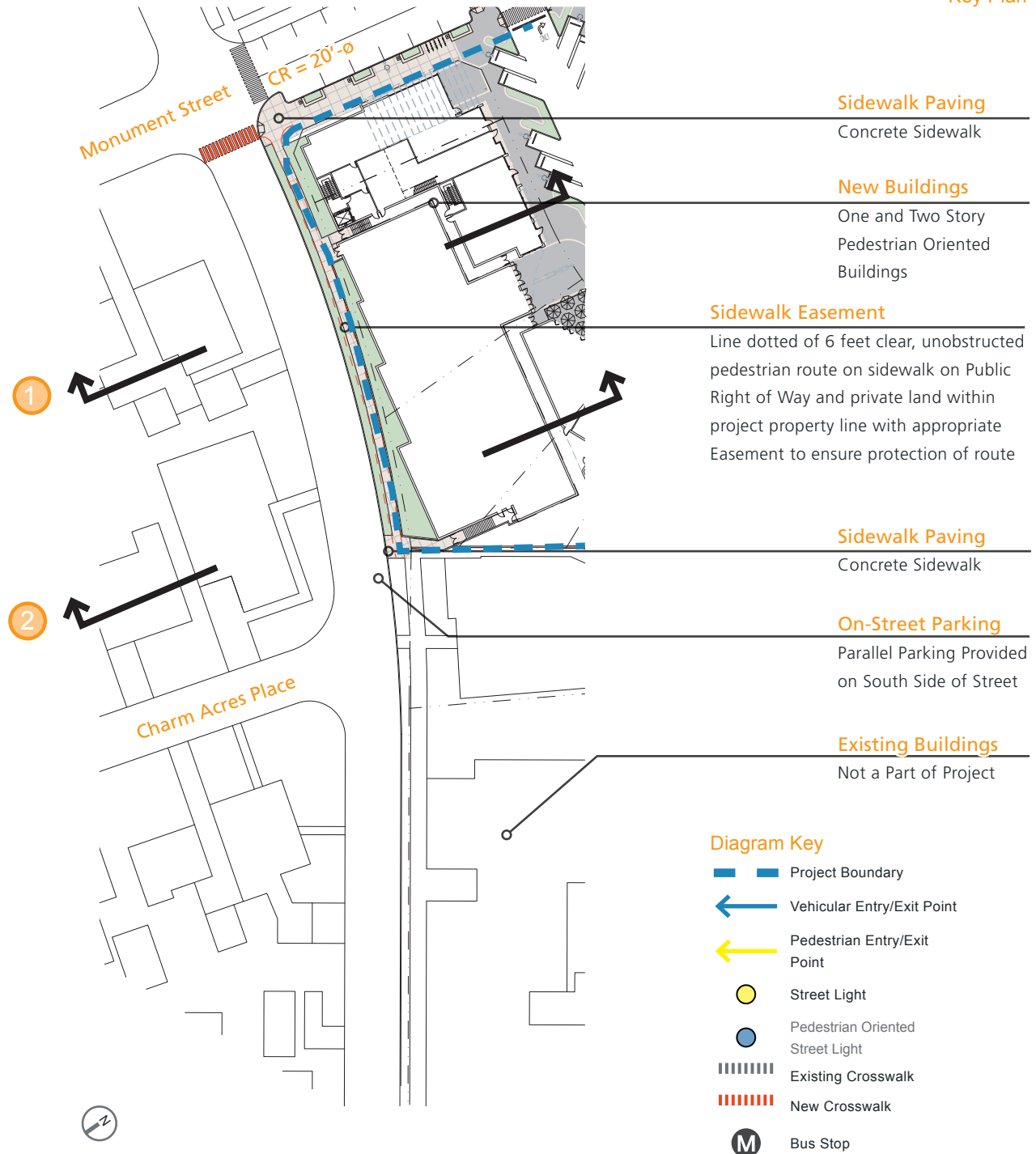

Albright Street

Streetscape Improvements: Street Sections

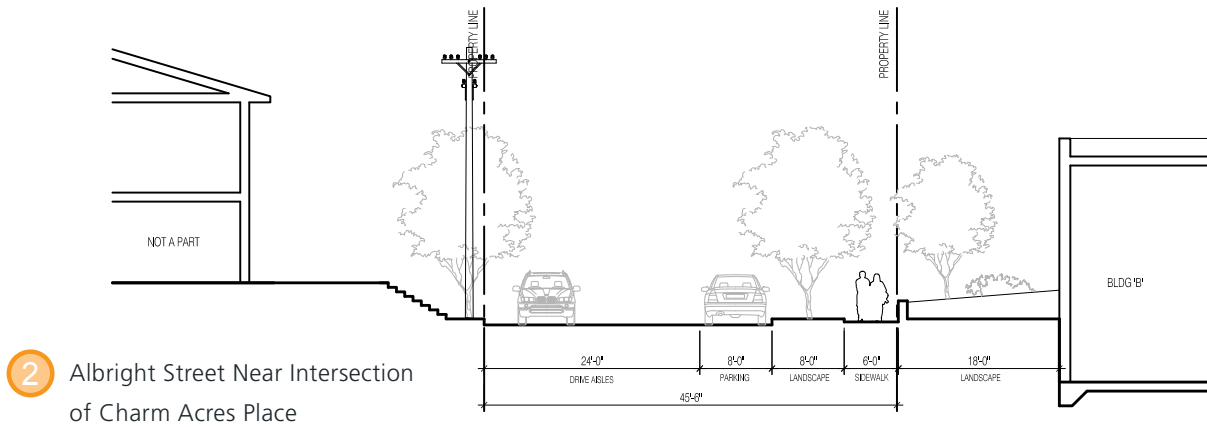
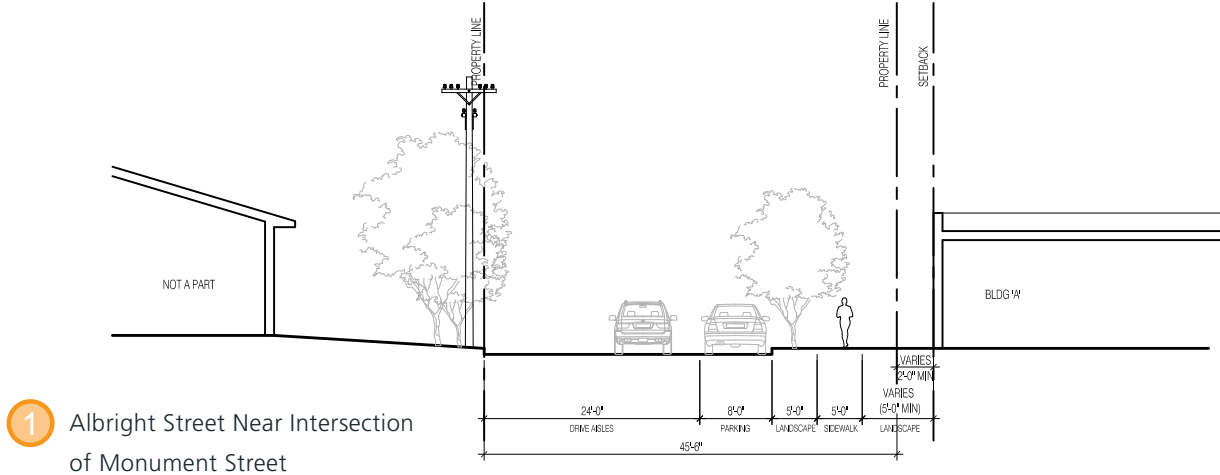

Albright Street

Streetscape Improvements: Street Planting Plan

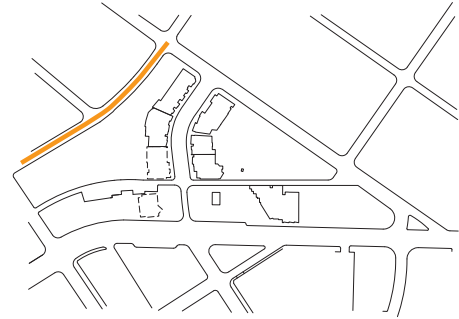

Key Plan

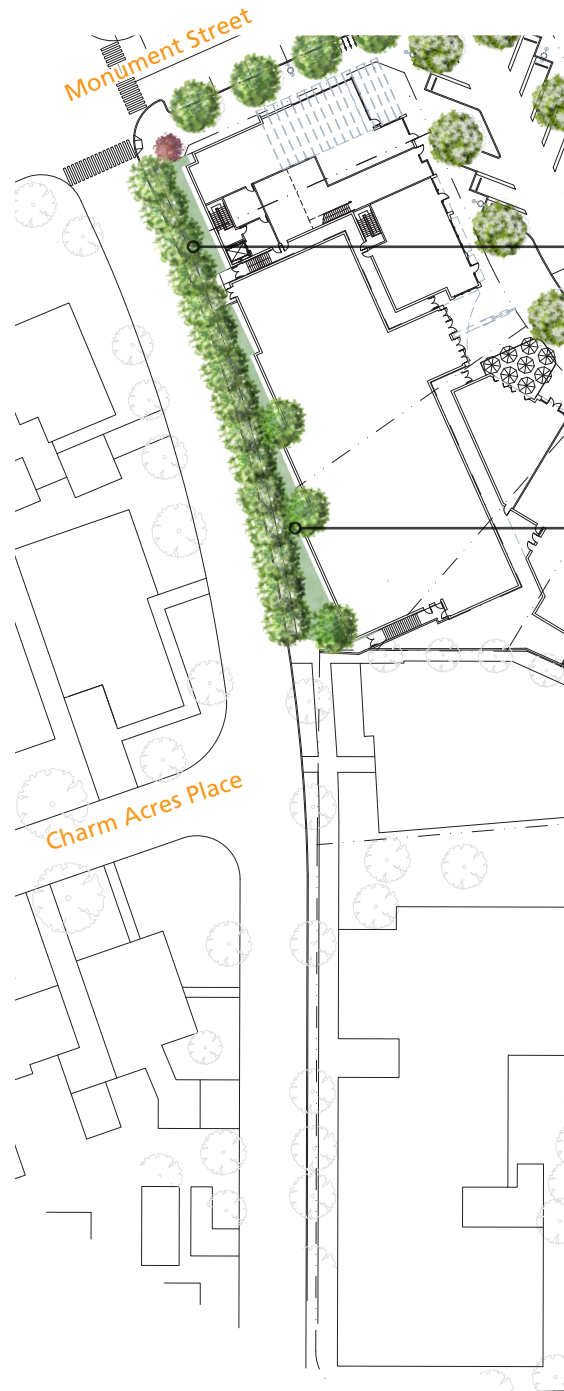

Sidewalk Trees

Lyonothamnus Trees
(Catalina Ironwood)

Ground Plantings & Shrubbery

Chapanula Poscharkyana,
agapantha Afrianus, Ficus Nitada



Landscape Plan Extract

Service Alley

Streetscape Improvements: Street Diagram

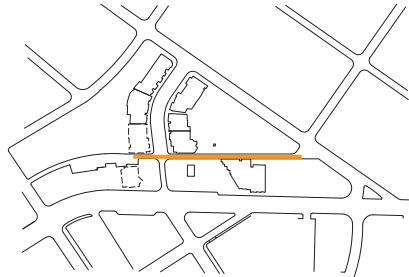

Key Plan

New Buildings

One and Two Story Pedestrian Oriented Buildings

Existing Buildings

Not a Part of Project

Diagram Key

- Project Boundary
- Vehicular Entry/Exit Point
- Pedestrian Entry/Exit Point
- Street Light
- Pedestrian Oriented Street Light
- Existing Crosswalk
- New Crosswalk
- Bus Stop

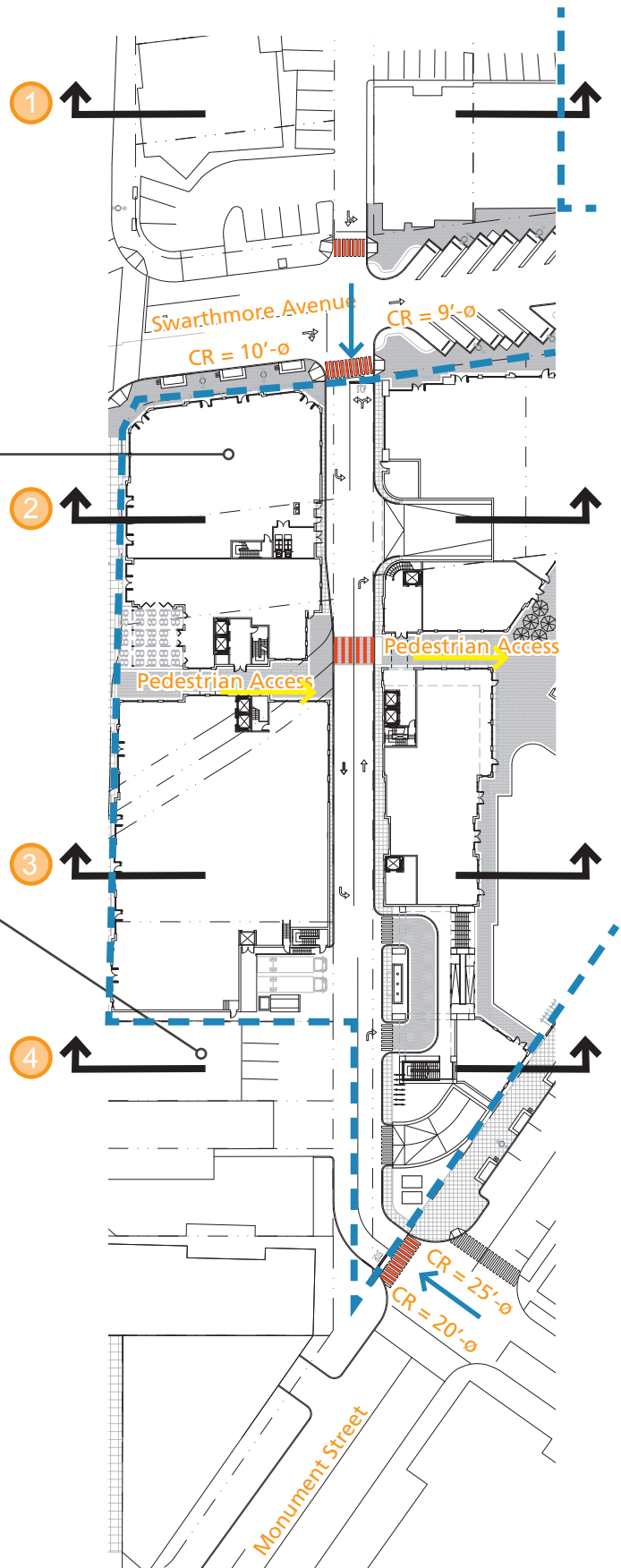

Service Alley

Streetscape Improvements: Street Sections

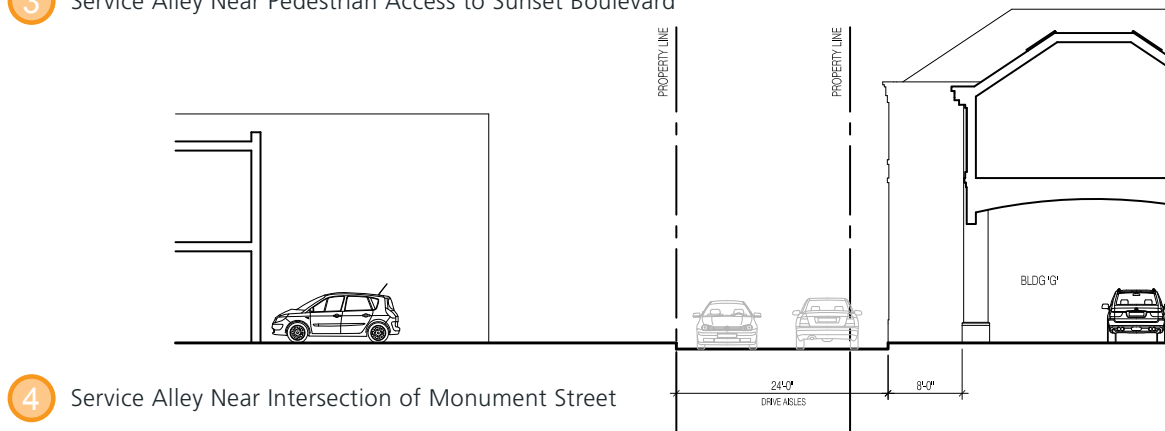
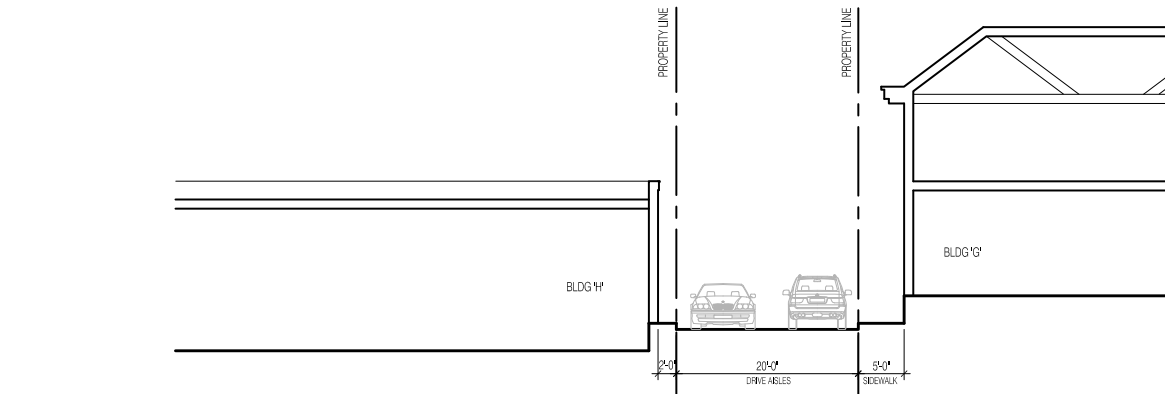
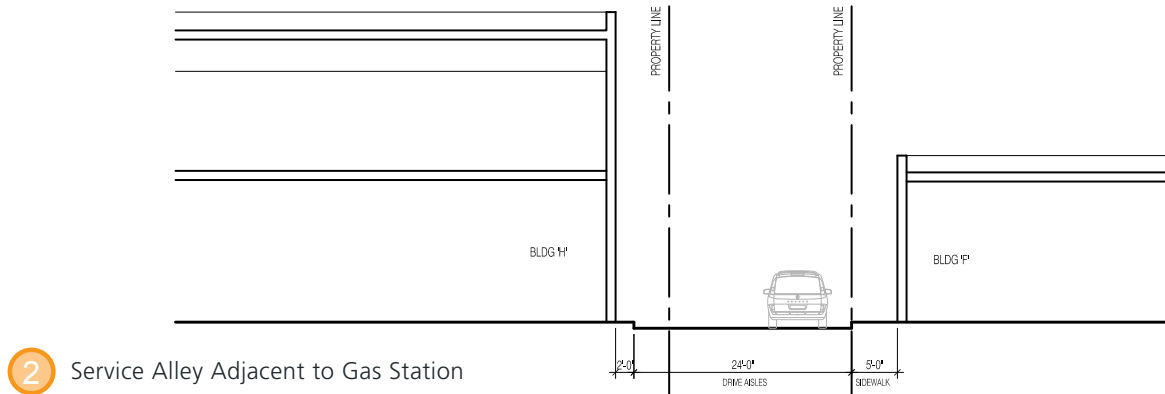
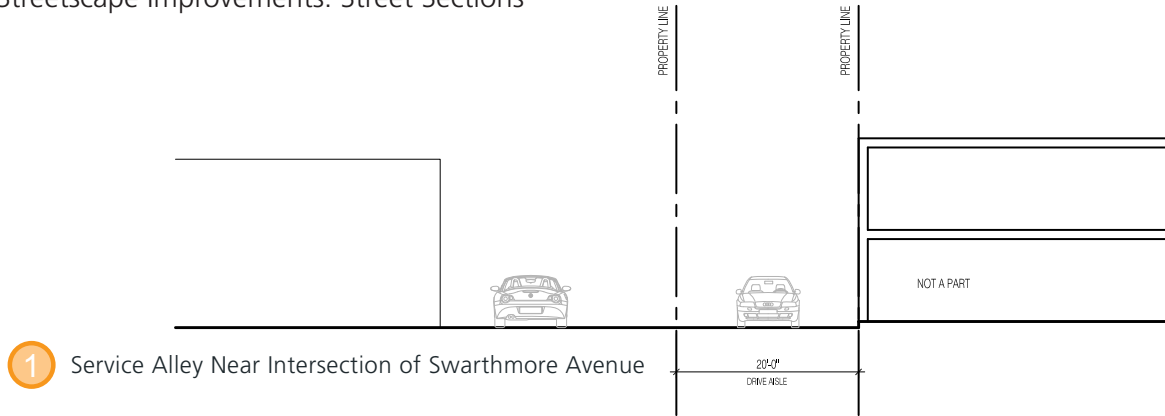

Service Alley

Streetscape Improvements: Street Paving Plan

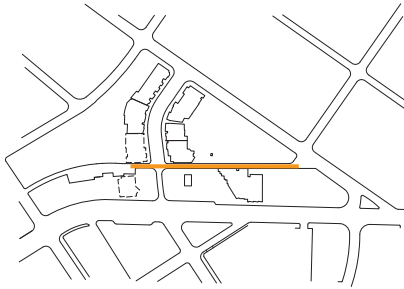

Key Plan

Sidewalk Paving

Concrete Sidewalk

Crosswalk Paving

Brick; Herringbone Pattern

Sidewalk Paving

Brick; Herringbone Pattern

Sidewalk Paving

Concrete Sidewalk

Sidewalk Paving

Concrete Sidewalk

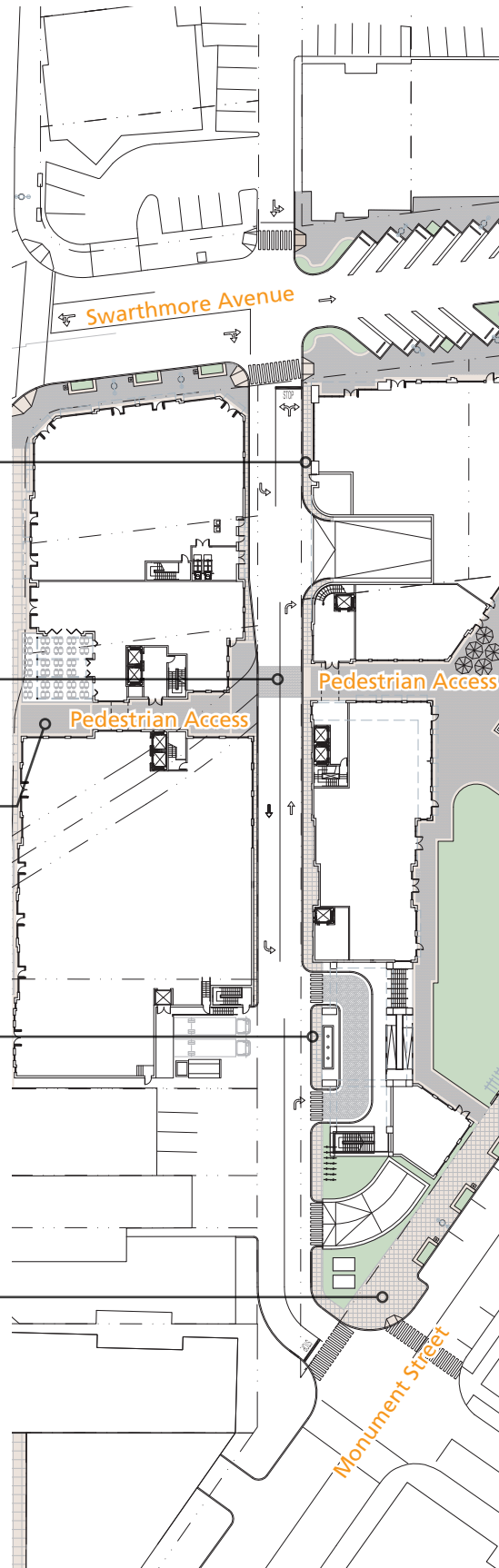

MATERIALS PALETTE

The Materials Palette includes landscape and street furnishing recommendations for project-wide and street-specific implementation. Guidelines and references to City Standards are included for the location of site furnishings.

A. Street Trees and Understory Planting

Trees should be planted from 36-inch boxes, 2-feet back from the curb. Minimum clear distances from infrastructure is defined by the city to be:

- Water and gas meters: 6-feet
- Driveway aprons and cross walks: 6-feet
- Fire hydrants: 10-feet
- Street lights: 20-feet
- Electrical power/Utility poles: 20-feet
- Alley entrance: 20-feet
- Intersection: 45-feet from the projected point of curb line intersection

1. Albright Street

Lyonothamnus floribundus (Catalina Ironwood) should be equally spaced, feet to feet on-center in a 5-foot wide parkway along the curb. The understory vegetation should be the low growing shrub *Agapanthus africanus* (African Lily).

a. Figure A.4.A.1.a: *Lyonothamnus floribundus* (Catalina Ironwood)

b. Figure A.4.A.1.b: *Agapanthus africanus* (African Lily)

2. Monument Street

Jacaranda mimosifolia (Jacaranda), should be equally spaced, 20 feet to 30 feet on-center in 4-foot by 10-foot wide planting areas along the curb. The tree and understory planting area should be aligned to allow for access to parallel parked cars. The understory vegetation should be *Diets iridioides* (African Iris).

a. Figure A.4.A.2.a: *Jacaranda mimosifolia* (Jacaranda)

b. Figure A.4.A.2.b: *Diets iridioides* (African Iris)



Figure A.4.A.3.a *Pyrus calleryana* 'Aristocrat'
(Aristocrat Pear)

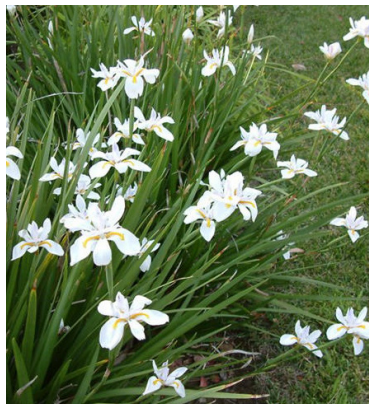

Figure A.4.A.3.b
Diets irioides (African Iris)

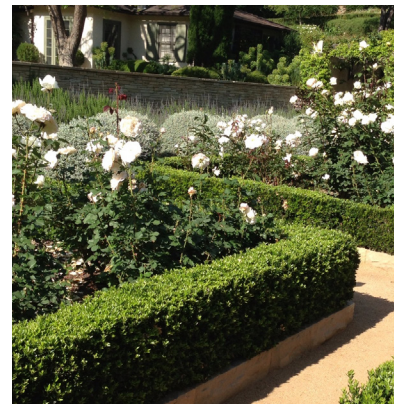

Figure A.4.A.3.c
Buxus sempervirens (Common Boxwood), *Rosa floribunda* 'Iceberg' (White Shrub Rose)

3. Swarthmore Avenue

Pyrus calleryana 'Aristocrat' (Aristocrat Pear) should be equally spaced, 20 feet to 25 feet on-center with 4-foot square planting areas at the end of the angled parking spaces. The understory vegetation should include *Dietes irioides* (African Iris). Larger planting areas along the avenue should include a perimeter of clipped hedge *Buxus sempervirens* (Common Boxwood) enclosing *Rosa floribunda* 'Iceberg' (White Shrub Rose).

- a. Figure A.4.A.3.a: *Pyrus calleryana* 'Aristocrat' (Aristocrat Pear)
- b. Figure A.4.A.3.b: *Dietes irioides* (African Iris)
- c. Figure A.4.A.3.c: *Buxus sempervirens* (Common Boxwood), *Rosa floribunda* 'Iceberg' (White Shrub Rose)

4. Sunset Boulevard

The two mature *Ficus microcarpa nitida* (Indian Laurel Fig), and one *Liquidambar styraciflua* (American Sweetgum), will be removed. Five *Koelreuteria bipinnata* (Chinese Flame Tree) should be equally spaced, 40 feet to 60 feet on-center in 4-foot by 10-foot wide planting areas along the curb. The tree and understory planting area should be aligned to allow for access to parallel parked cars. Understory planting will not be installed.

- a. Figure A.4.A.4.a: *Koelreuteria bipinnata* (Chinese Flame Tree)
- b. Figure A.4.A.4.b: *Strelitzia reginae* (Bird of Paradise)



Figure A.4.A.1.a
Lyonothamnus floribundus (Catalina Ironwood)



Figure A.4.A.2.b
Diets irioides (African Iris)



Figure A.4.A.1.b
Arctostaphylos 'Pacific Mist' (Pacific Mist Manzanita)



Figure A.4.A.2.a
Jacaranda mimosifolia (Jacaranda)



Figure A.4.A.4.a
Koelreuteria bipinnata (Chinese Flame Tree)

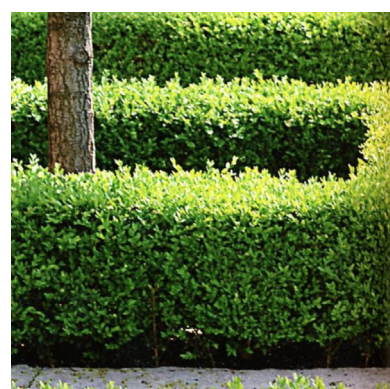

Figure A.4.A.4.b
Buxus sempervirens (Common Boxwood)

B. Pedestrian Pavement

The project area public right-of way will meet all the City of Los Angeles standards. The materials, quality and character will extend from the public right-of-way to the building façade, into and through the project.

1. Albright Street, Monument Street, Alley and Sunset Boulevard

Pavement should be natural gray concrete with a light broom finish and scored in a rectangular patterns parallel to the curb. The scoring pattern should be a 12-inch to 18-inch grid to enhance the sense of scale and detail along the sidewalk.

2. Swarthmore Avenue and a Segment of Sunset Boulevard at the Paseo Entrance

Paved with brick or concrete unit pavers. Unit paver sidewalks shall utilize a combination of herringbone, block/stacked & standard coursed patterns. (Figure AA. 1) Additional pavement materials should be included to add to the character of Swarthmore Avenue including cast-in-place concrete, scored in 12-inch to 24" squares, stone and concrete pavers (Figure AA.2).

C. Crosswalks

Crosswalks will be maintained at the intersections of Monument Street and Bashford Street; Swarthmore Avenue and Sunset Boulevard, Sunset Boulevard and Antioch Street in keeping with the City of Los Angeles standards. Crosswalks will be standard street paint on asphalt. Brick pavers and/or cast-in-place concrete will extend across Swarthmore Avenue between the expanded pedestrian sidewalks lining the cinema plaza and paseo.

D. Site Furnishings

Street furniture will meet the City of Los Angeles standards for character, quality and location. A Revocable Permit may be required for the installation of furniture in the public-right-of-way. (Note that the representative street furnishings below are to demonstrate the level of quality and finish. The final selection and design of the street furnishings may be subject to change).

1. Seating

- a. Dumar 165 Series Bench with steel supports painted black with Ipe wood slats. (Figure A. 1)

2. Bicycle Racks

- a. Maglin MBR200 Series Bike Rack, Color/Finish to be black (Figure A.2)

3. Trash and Recycling Receptacles

- a. WITT Industries Oakley M3600R OR Receptacle, Color to be black (Figure A.3)



Figure AA.1 Brick sidewalk

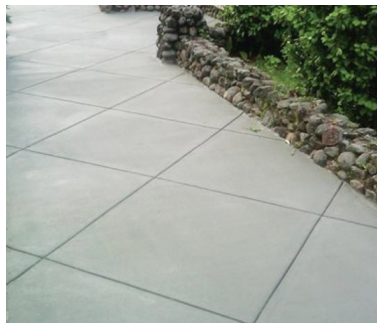

Figure AA.2 Cast-in-place scored concrete



Figure A.1 Teak Warehouse Bowback Small Bench

4. Bollard

- a. Fair Weather Bollard Model B-1-6, Color to be black (Figure A.4)

5. Detectable Warning Surface

- a. Irondome Cast Iron Tactile Tile (Figure A.5)

6. Pedestrian lighting

- a. Custom Light Pole Type A - Based upon DABMAR Post Fixture GM-9000 (Figure A.6a)
- b. Custom Light Pole Type B - Based upon DABMAR Post Fixture GM-9270 (Figure A.6b)

7. Parking Bumpers

- a. Century Group concrete parking bumper. (Figure A.7)

8. Tree Guard

- a. Ironsmith Tree Guard Model M-3. Color to be black.

9. Tree Grate

- a. Ironsmith Tree Grate Model 3660 ADA. Color to be black. (Figure A.8)



Figure A.2
Maglin MBR200 Series
Bike Rack



Figure A.3
WITT Industries Oakley M3600R



Figure A.4
Fair Weather Bollard
Model B-4-6



Figure D.5
Irondome Cast Iron Tactile Tile



Figure D.6a
Custom Light Pole Type A - Based upon DABMAR Post
Fixture GM-9000



Figure D.6b
Custom Light Pole Type B - Based upon
DABMAR Post Fixture GM-9270

10.Tree Lighting

- a. SPJ Li'L Beast directional light. Color to be Matte Bronze. (Figure A.9)

11.BUS SHELTER

The existing bus stop is south of the project in the triangle island at the intersection of Sunset Boulevard and Monument Street. No shelter exists. A new bus shelter is not included in the Palisades Village project.



Figure A.7
Century Group Parking Bumper



Figure A.8
Ironsmith Tree grate 3660 ADA



Figure A.9
SPJ Li'L Beast Directional Light



Figure A.10
Decorative Iron Rail

Site Signage

Proposed Improvements: Vehicular Wayfinding

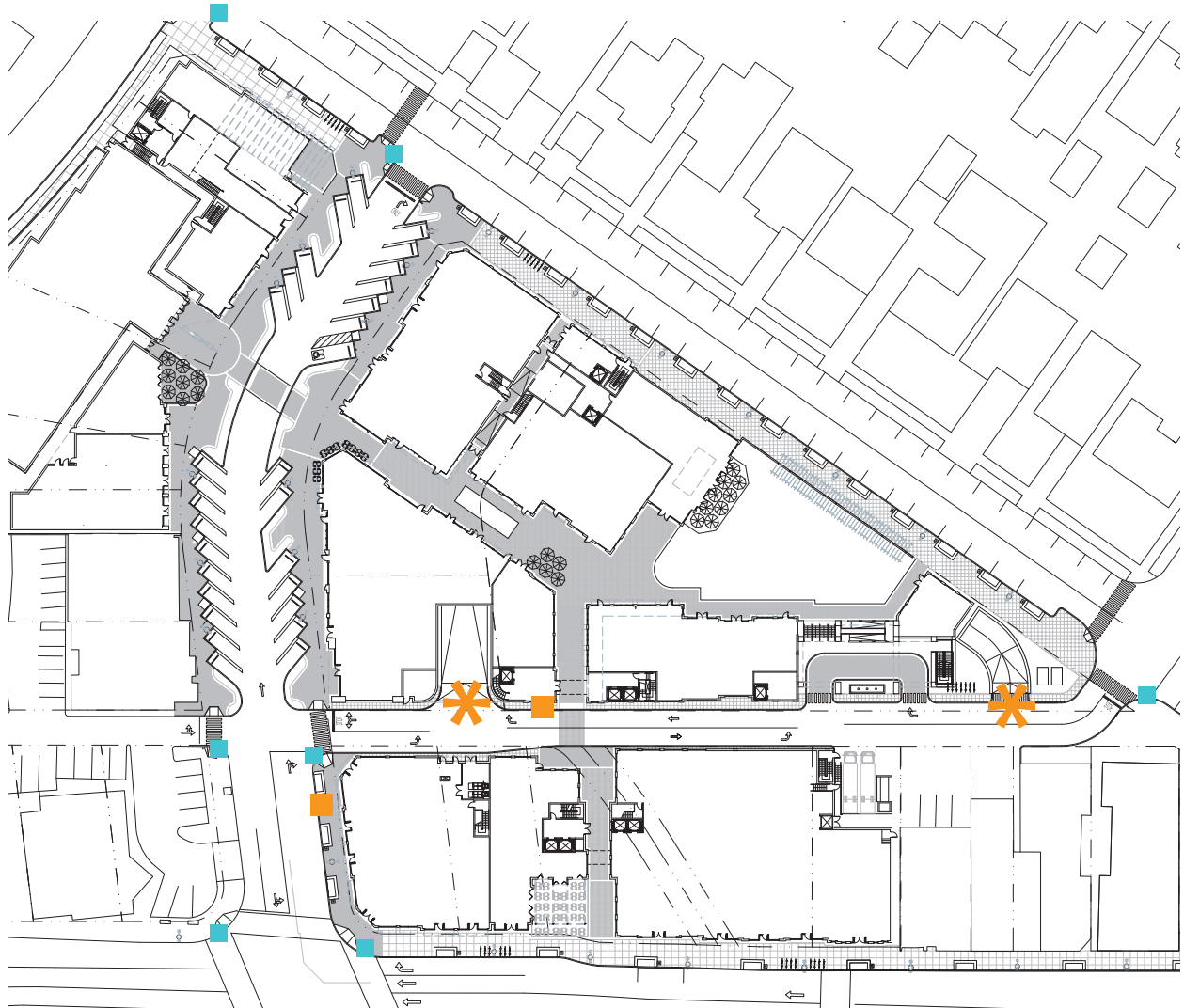





Figure A.11
Vehicular Wayfinding Sign Types

-  Garage Entrance with Clearance Bar to Parking Garage
-  Street ID Sign – This street ID location is optional if there is no entry gateway at this location
-  Vehicular Wayfinding Sign

Site Signage

Proposed Improvements: Vehicular Wayfinding

Vehicular Wayfinding Sign Family

The sign family below are massing studies of typical wayfinding signs addressing the public garage.

Street Name Signage

Example of City of Los Angeles standard

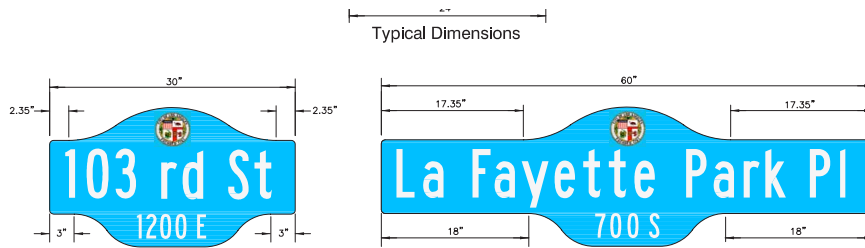

Figure A.12
Street Name Sign Family

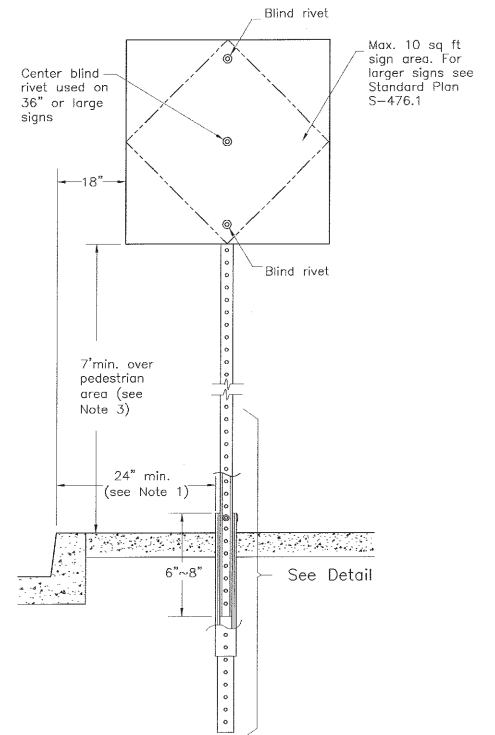
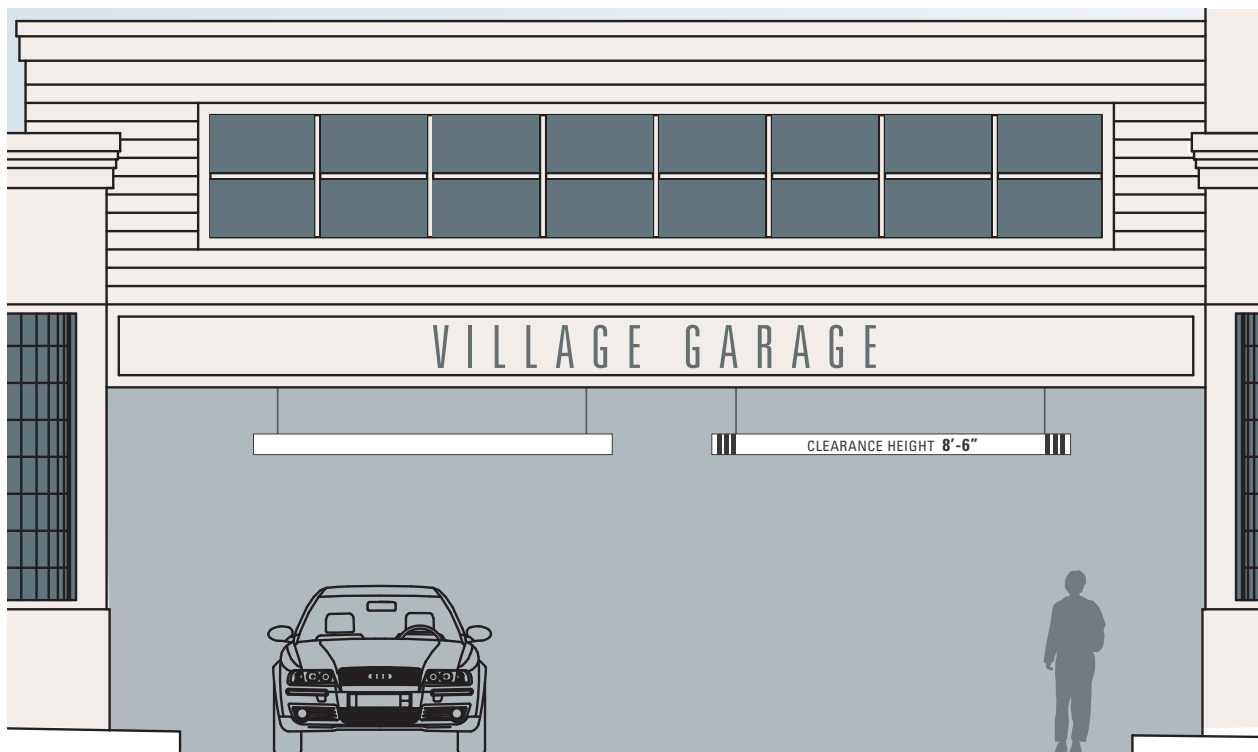

Figure A.13
City of Los Angeles Standard Sign Pole



Site Signage

Proposed Improvements: Vehicular Wayfinding

Vehicular Wayfinding Sign Family

The sign family below are a sidewalk mounted monument sign on Swarthmore and a building mounted sign on the Service Alley to direct vehicular traffic to the public garage.

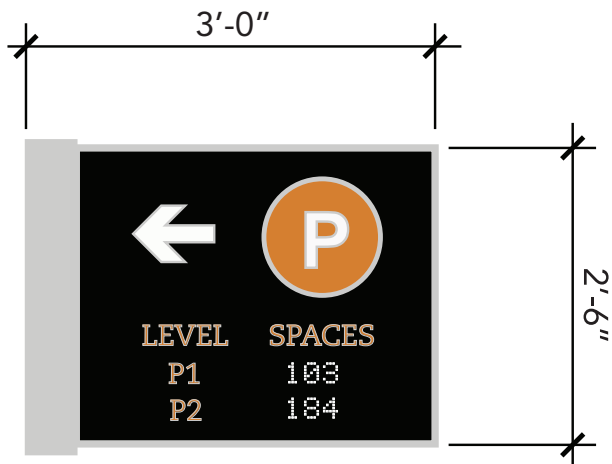

Building-Mounted Sign

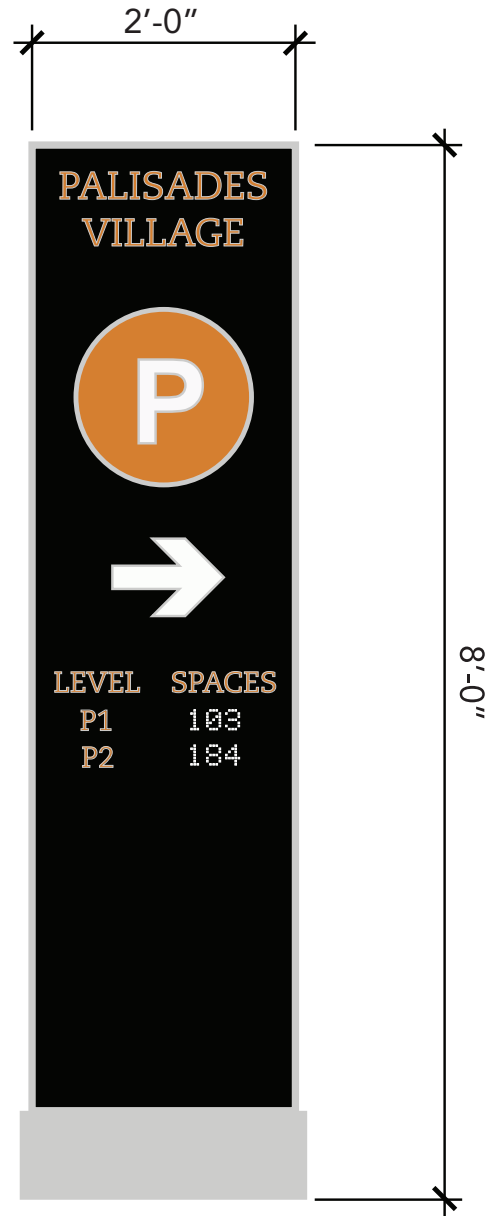

Monument Sign

Regulatory Sign Family

The selection and mounting of all regulatory signs shall be in accordance with the City of Los Angeles signage standards.

Examples of Regulatory Signs



Figure D.14
Vehicular Wayfinding Sign Family

Appendix B: Master Sign Program

Appendix B

Master Sign Program

I. PREFACE

These Commercial Tenant Sign Regulations (“Sign Regulations”) establish standards and criteria for the design, implementation, and regulation of commercial tenant identity signs at the Palisades Village Project (Case No. CPC-2015-2714-VZC-SP-DRB-SPP) in Pacific Palisades, Los Angeles, California (“Project”).

These Sign Regulations have been developed to compliment the design intent of the architecture of the Project and provide a smaller scale of design detail and color that adds vibrancy and character to the Project as well as identifying the Project’s amenities and tenants.

II. OBJECTIVES

The objectives of these Sign Regulations are:

- To generate creative and tasteful signage that enhances the Project’s image and compliments architectural and landscape elements.
- To provide signage that is functional and effectively serves the identification needs of the Project and its tenants.
- To facilitate the review and approval process for signage by providing standards and criteria that constitute standards of acceptability for signs at the Project to be administered and enforced by Owner/Landlord.

III. SIGN REGULATIONS

The following are regulations that apply to the development of all signage and graphic elements.

A. Prohibitions. The following signs are expressly prohibited:

1. Off-site commercial signs.
2. Roof signs.
3. Window Signs, (except store names, store hours, logos, and holiday paintings which must be removed within five business days after the holiday).
4. Animated signs, including flashing neon signs.
5. Bench signs.
6. Pole signs and monument signs.

B. Requirements. All signs, except as provided in Subsections C of this Appendix, shall conform to the following criteria:

1. The total sign area shall not exceed two square feet for each of the first 20 feet of building frontage which is adjacent to a public access way and one square foot for each linear foot of building frontage which exceeds the first 20 feet. A public access way can include a street, sidewalk, or paseo in or adjacent to the project.
2. Where buildings or structures occupy a corner site, total sign area shall be 1.5 times the building frontage. For such corner locations, no more than two-thirds of the total allowable sign area shall be permitted facing on any one of the street frontages.
3. For all buildings occupied by several businesses or uses, the size of signs pertaining to each business or use is governed by the proportion of the building frontage occupied by that business or use.
4. Where there is a public entrance from an alley or from a parking lot in addition to the main entrance, there shall be permitted an additional sign area of one-half square foot for each linear foot on that side of the lot, not to exceed 20 square feet in area. If there is no public entrance on that side of the building, sign area is limited to a blade sign, not to exceed three square feet in sign area.
5. No single sign shall exceed 100 square feet in sign area, with the exception of a theater marquee sign (Section C).
6. Marquee signs and signs attached to awnings may not project above the marquee or awning; may not extend more than 12 inches below the marquee or awning; and shall be at least eight feet above the sidewalk or ground.
7. One Symbol Sign shall be permitted for each business or use and is not included in aggregate size limits. A Symbol Sign may not exceed three square feet in total area and must project from the building or structure or wrought iron brackets of uniform size established by the Design Review Board.
8. Notwithstanding Subsections (c), (d), and (e) of LAMC Section 62.132, banners shall only be permitted if (a) the banner is hung on a 4-foot flag pole; (b) it is attached to the front of a building or structure; and (c) there is clearance of at least 12 feet above the adjacent grade. Banners shall be a uniform size of four by two and one-half feet and may not be displayed for more than 30 days.
9. All signs, other than those described in Subdivisions 6, 7, 8, and 10 of this Subsection shall be parallel to building walls or facades.
10. Temporary Signs inside a building and visible from the outside shall be set back at least six inches from a window and may not be displayed of more than 30 days. The total sign area of such sign shall not exceed 20 percent of the total square footage of the window.
11. No sign shall be attached directly to either the inside or outside of any window or door, except for store names, store hours and logos.
12. Any store hours sign shall be placed in the front door or window closest to the front door. Such sign shall not exceed three square feet in sign area.

C. Marquee Sign

1. Allow for a marquee sign up to 30 feet above adjacent sidewalk grade.
2. Allow for a sign area of up to 200 square feet per face. The fixed sign area shall be a minimum of 100 square feet. The fixed sign shall be considered a building identification sign for Building B on Exhibit B dated May 24, 2016, of the project plans for the Palisades Village Project (Case No. CPC-2015-2714-VZC-SP-DRB-SPP). The physical character of the fixed sign shall match Figure 3 – Marquee Sign Elevation (Enlarged). Off-site messaging is not allowed in the changeable copy area.

IV. RELATIONSHIP TO SPECIFIC PLAN AND LAMC

These Sign Regulations supplement the Specific Plan and the Los Angeles Municipal Code with respect signage for the Palisades Village Project (Case No. CPC-2015-2714-VZC-SP-DRB-SPP). Wherever these Sign Regulations conflict with the provisions of the Los Angeles Municipal Code or the Pacific Palisades Commercial Village and Neighborhoods Specific Plan (“Specific Plan”), these Sign Regulations shall control and supersede to the extent of the conflict.

The review and approval procedures for signage within the Commercial Village Subarea A shall be as set forth in Section 13.B.13 of this Specific Plan. The Specific Plan provisions related to the Abatement of Nonconforming Signs shall apply to signage within the Commercial Village Subarea A.

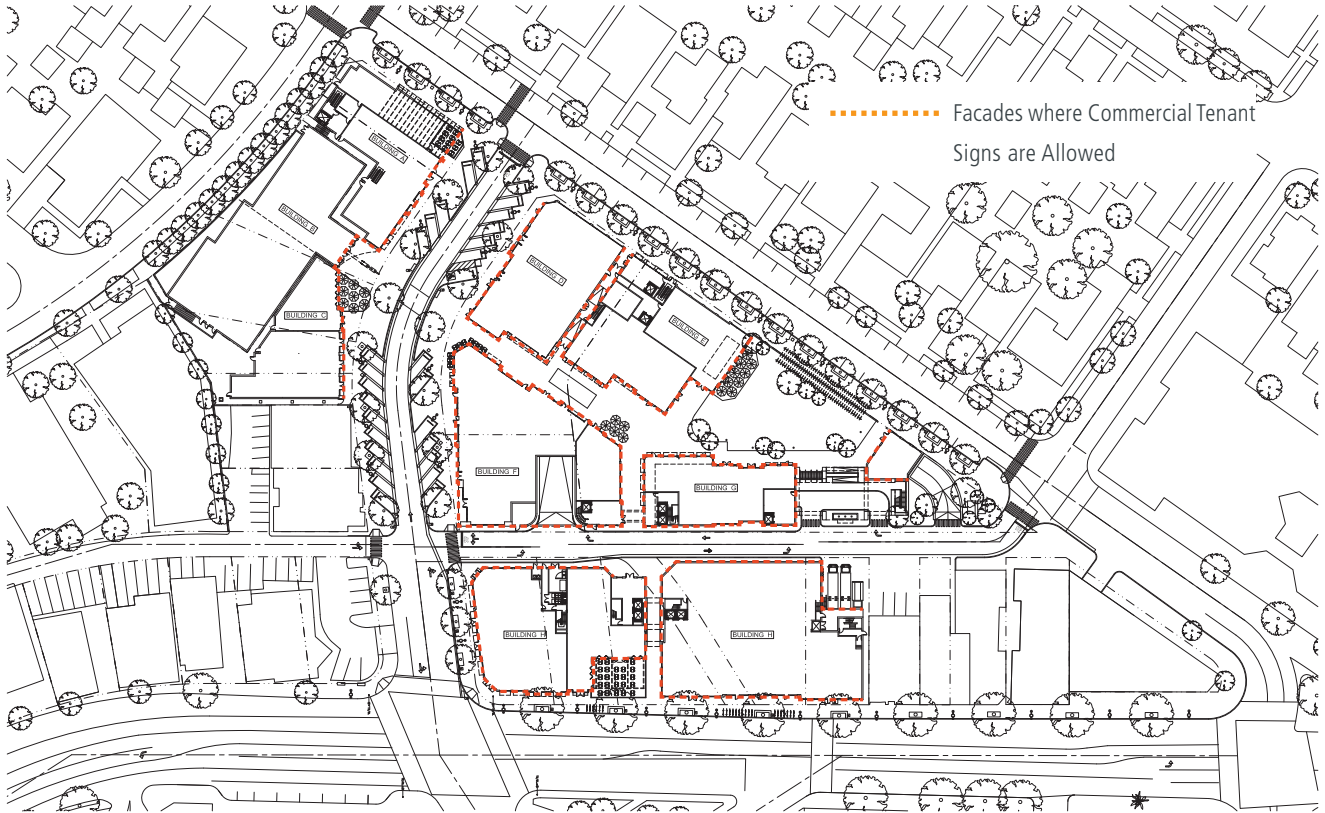

Figure 1 - Master Sign Program

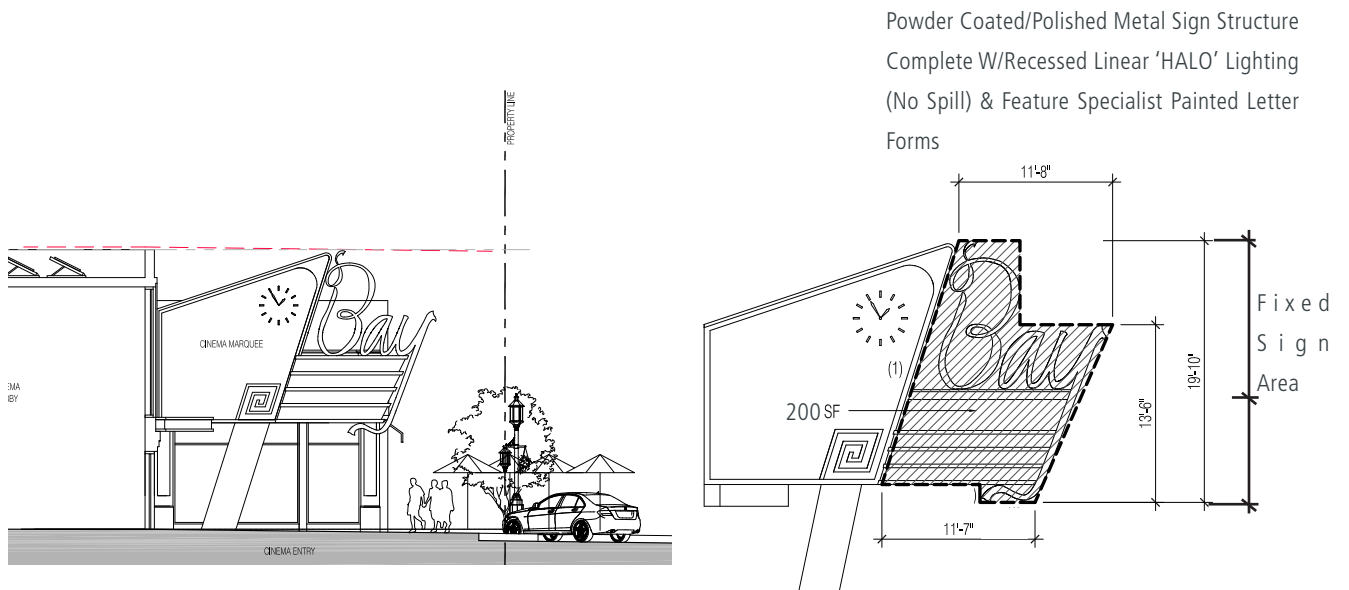

Figure 2 - Marquee Sign - Height

Figure 3 - Marquee Sign Elevation (Enlarged)

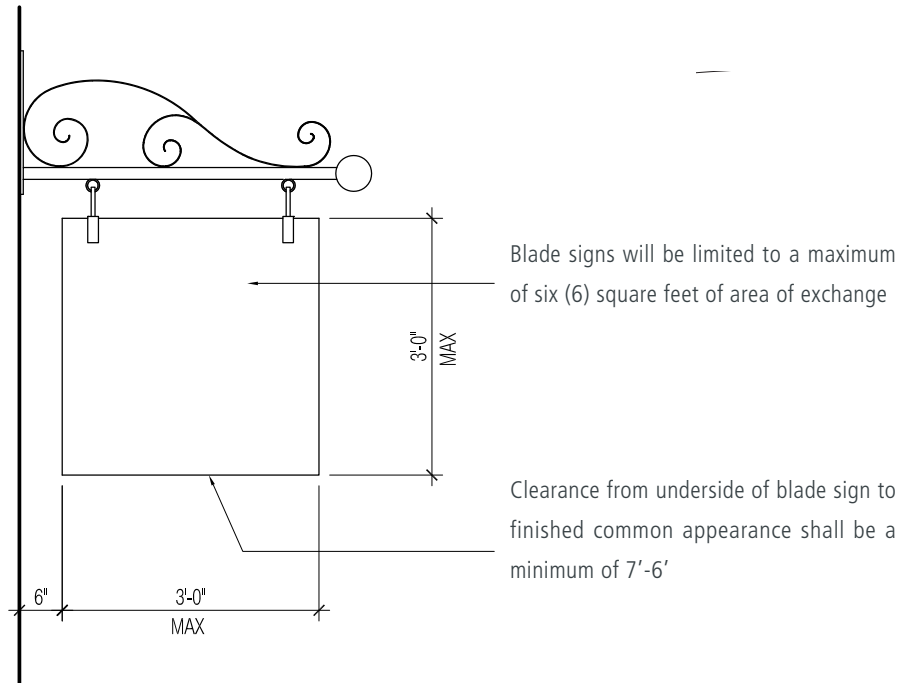

Figure 4 - Tenant Blade Sign Elevation

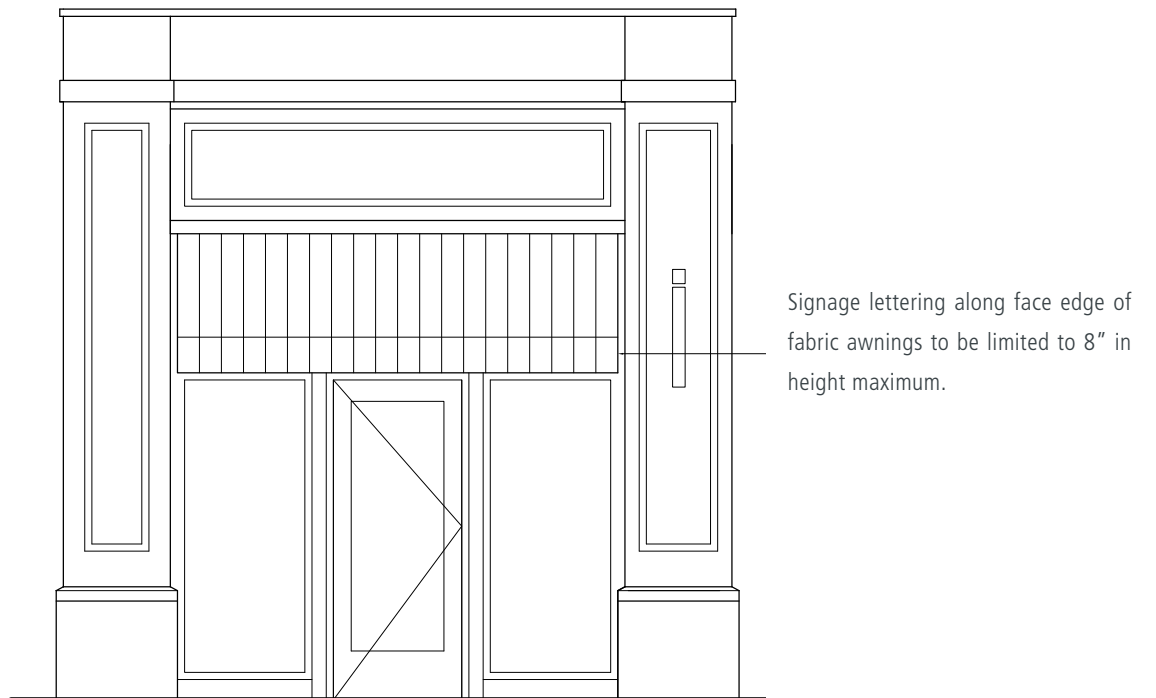

Figure 5 - Tenant Awning Elevation

Tenant Blade Signs

One blade sign shall be permitted for each business or use and is not included in aggregate size limits. A blade sign may not exceed three square feet in total area and must project from the building or structure or wrought iron brackets of uniform size .



Figure 6 - Corner Tenant Storefront Wall Sign

Corner Tenant Storefront

Where buildings or structures occupy a corner site, total sign area shall be 1.5 times the building frontage. For such corner locations, no more than two-thirds of the total allowable sign area shall be permitted facing on any one of the street frontages.

Allowable Signage Area Example

Frontage	Multiple	Signage Area Allowed
50'-0"	1.5	75'-0" sf

No side may exceed two thirds or square feet of the total allowable sign area.



Figure 7 - Typical Tenant Storefront Wall Sign

Typical Tenant Storefront

The total sign area shall not exceed two square feet for each of the firstfeet of building frontage which is adjacent to a public access way and one square foot for each linear foot of building frontage which exceeds the firstfeet.

Allowable Signage Area Example

Frontage	Multiple	Signage Area Allowed
20'-0"	2	75'-0" sf

Note that tenant storefronts whose rear facades front a vehicular alley shall also be allowed to place a tenant storefront sign on the rear façade equal in size to the allowable storefront sign per the tenant's frontage, if the rear façade includes a pedestrian entrance.